

# ANNOUNCED SPECIFICATION OF HS-945MG STANDARD CORELESS MOTOR HIGH TORQUE SERVO

## 1. TECHNICAL VALUES

CONTROL SYSTEM	:+PULSE WIDTH CONTROL 1500usec NEUTRAL	
OPERATING VOLTAGE RANGE	:4.8V TO 6.0V	
OPERATING TEMPERATURE RANGE	:-20° C TO +60° C	
TEST VOLTAGE	:AT 4.8V	AT 6.0V
OPERATING SPEED	:0.16sec/60° AT NO LOAD	0.12sec/60° AT NO LOAD
STALL TORQUE	:8.8kg.cm(122.2oz.in)	11kg.cm(152.75oz.in)
OPERATING ANGLE	:45°/ONE SIDE PULSE TRAVELING 400usec	
DIRECTION	:CLOCK WISE/PULSE TRAVELING 1500 TO 1900usec	
IDLE CURRENT	:5.3mA	6.6mA
RUNNING CURRENT	:400mA	500mA
DEAD BAND WIDTH	:4usec	
CONNECTOR WIRE LENGTH	:300mm (11.81in)	
DIMENSIONS	:39.4x20x37.8mm(1.55x0.78x1.48in)	
WEIGHT	:56g(1.97oz)	

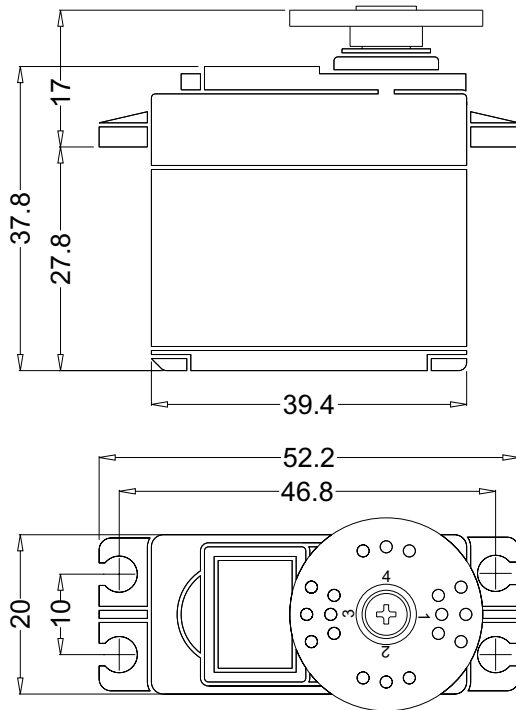

## 2. FEATURES

- CORELESS MOTOR
- LONG LIFE POTENTIOMETER
- 3-METAL GEARS & 1-RESIN METAL GEAR
- DUAL BALL BEARING
- WATERPROOF AND DUSTPROOF
- INDIRECT DRIVE POTENTIOMETER
- GOLD PLATED CONTACTS
- MOS FET MOTOR DRIVERS

## 3. APPLICATIONS

- HIGH PERFORMANCE AIRCRAFT TO 1/4 SCALE
- 30 AND LARGER HELICOPTERS
- STEERING AND THROTTLE FOR 1/10TH & 1/8TH ON-ROAD AND OFF-ROAD VEHICLES