

ANNOUNCED SPECIFICATION OF HS-5945MG STANDARD DELUXE DIGITAL CORELESS MOTOR HIGH TORQUE SERVO

1. TECHNICAL VALUES

CONTROL SYSTEM	:+PULSE WIDTH CONTROL 1500usec NEUTRAL	
OPERATING VOLTAGE RANGE	:4.8V TO 6.0V	
OPERATING TEMPERATURE RANGE	:-20°C TO +60°C	
TEST VOLTAGE	:AT 4.8V	AT 6.0V
OPERATING SPEED	:0.16sec/60° AT NO LOAD	0.13sec/60° AT NO LOAD
STALL TORQUE	:11kg.cm(152.75oz.in)	13kg.cm(180.53oz.in)
OPERATING ANGLE	:40°/ONE SIDE PULSE TRAVELING 400usec	
DIRECTION	:CLOCK WISE/PULSE TRAVELING 1500 TO 1900usec	
IDLE CURRENT	:3mA	3mA
RUNNING CURRENT	:180mA	230mA
DEAD BAND WIDTH	:1usec	
CONNECTOR WIRE LENGTH	:220mm(8.66in)	
DIMENSIONS	:39.4x20x37.8mm(1.55x0.78x1.48in)	
WEIGHT	:56g(1.97oz)	

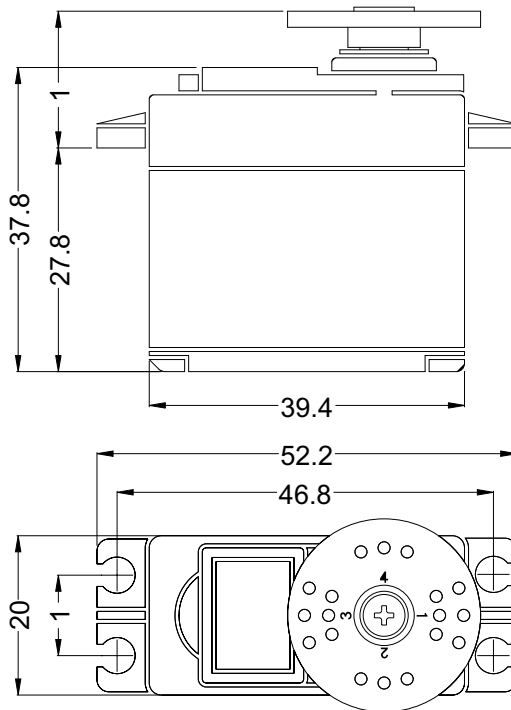

2. FEATURES

- DIGITAL & MOS FET AMP
- PROGRAMABLE
- CORELESS MOTOR
- LONG LIFE POTENTIOMETER
- 3 METAL GEARS
- DUAL BALL BEARING
- WATERPROOF AND DUSTPROOF
- INDIRECT DRIVE POTENTIOMETER
- GOLD PLATED CONTACTS
- NARROW DEAD BAND WIDTH AND HIGH STANDING TORQUE

3. APPLICATIONS

- HIGH PERFORMANCE AIRCRAFT TO 1/4 SCALE
- 30 AND LARGER HELICOPTERS
- STEERING AND THROTTLE FOR 1/10TH & 1/8TH ON-ROAD AND OFF-ROAD VEHICLES