

ANNOUNCED SPECIFICATION OF HS-545BB STANDARD PRECISION HIGH TORQUE SERVO

1. TECHNICAL VALUES

| | | |
|-----------------------------|---|------------------------|
| CONTROL SYSTEM | : +PULSE WIDTH CONTROL 1500usec NEUTRAL | |
| OPERATING VOLTAGE RANGE | : 4.8V TO 6.0V | |
| OPERATING TEMPERATURE RANGE | : -20 TO +60° C | |
| TEST VOLTAGE | : AT 4.8V | AT 6.0V |
| OPERATING SPEED | : 0.22sec/60° AT NO LOAD | 0.17sec/60° AT NO LOAD |
| STALL TORQUE | : 4.4kg.cm(61.1oz.in) | 5.5kg.cm(76.37oz.in) |
| OPERATING ANGLE | : 45°/ONE SIDE PULSE TRAVELING 400usec | |
| DIRECTION | : CLOCK WISE/PULSE TRAVELING 1500 TO 1900usec | |
| CURRENT DRAIN | : 8mA/IDLE AND 250mA NO LOAD RUNNING | |
| DEAD BAND WIDTH | : 6usec | |
| CONNECTOR WIRE LENGTH | : 300mm(11.81in) | |
| DIMENSIONS | : 39.8x19.8x35.8mm(1.56x0.77x1.4in) | |
| WEIGHT | : 44.5g(1.56oz) | |

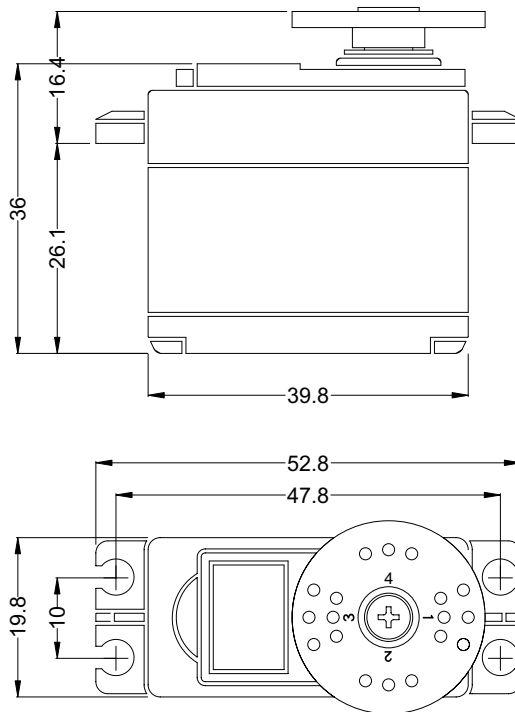

2. FEATURES

- 5-POLE FERRITE MOTOR
- LONG LIFE POTENTIOMETER
- INDIRECT POTENTIOMETER DRIVE
- 1-OILITE BUSHING AND 1-BALL BEARING
- GOLD PLATED CONNECTOR PINS

3. APPLICATIONS

- PRECISION AIRCRAFT SERVO
- STEERING AND THROTTLE SERVO FOR 1/10TH ON-ROAD AND OFF-ROAD VEHICLES