

# HS-318 General Specification.

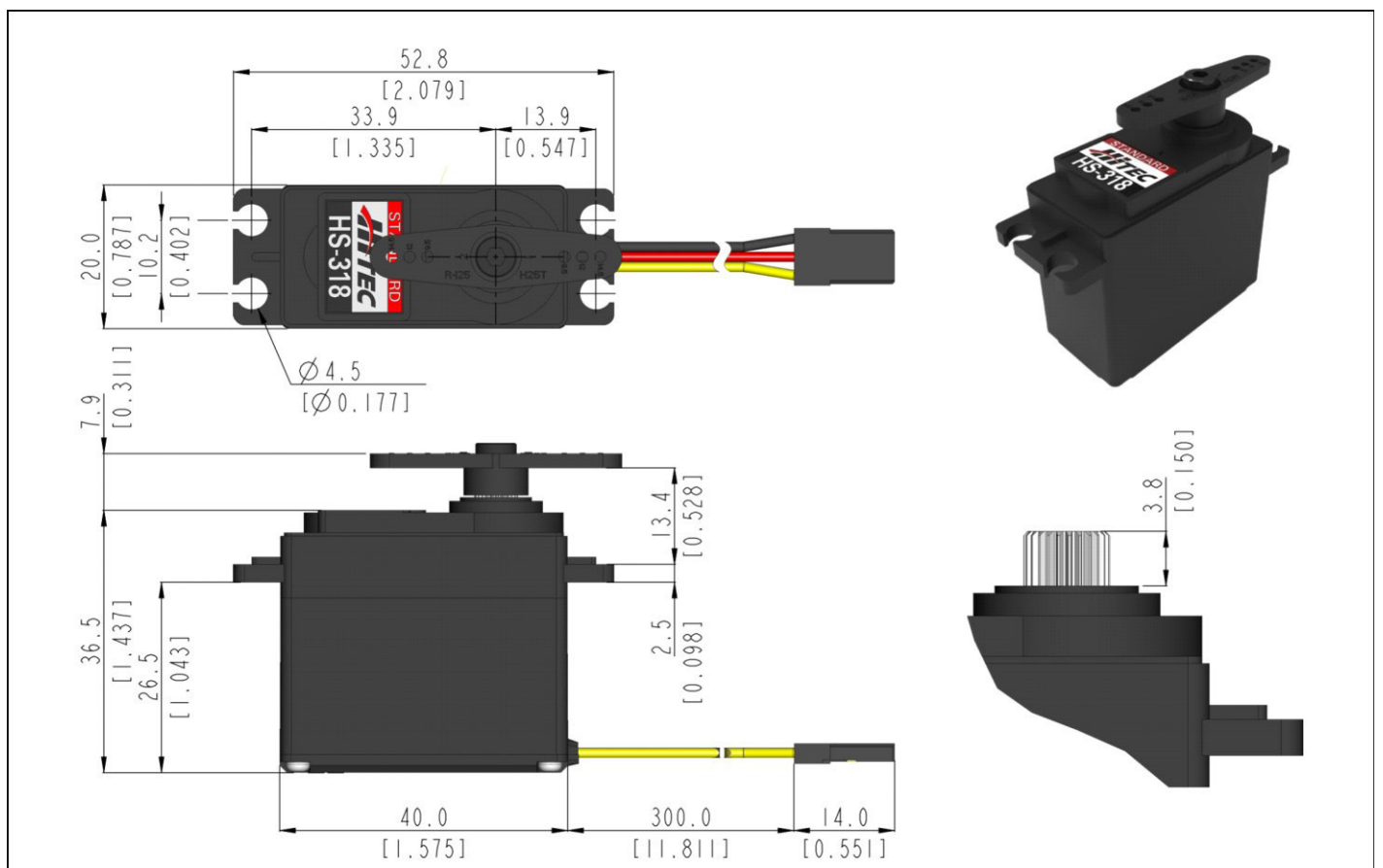

Control System	PWM			-
Position Sensor Type	Contact Analog Potentiometer			-
Motor Type	Cored Metal Brush			At 25°C(±10%), 45%RH(±10%) <u>measurement environment</u>
Operating Voltage Range	4.8 ~ 6.0V			
Voltage	4.8V	6.0V	-	
No Load Speed	0.19sec/60°	0.15sec/60°	-	
Stall Torque	3.0kgf·cm (41.66oz-in)	3.7kgf·cm (51.38oz-in)	-	
Peak Efficiency Torque	0.6kgf·cm ( 8.3 oz-in)	0.7kgf·cm ( 9.7 oz-in)	-	
Standing Current	7mA	8mA	-	
No Load Running Current	160mA	180mA	-	
Stall Current	700mA	800mA	-	
Deadband	5μs	5μs	-	
Operating Travel	Default: ±60°, Non-programmable / Pulse Width: 900~2100μs(Center:1500μs)			
Continuous Rotation	n/a			
Operating Temperature Range	-20°C ~ +60°C (-4°F ~+140°F)			-
Storage Temperature Range	-30°C ~ +80°C (-22°F ~+176°F)			-
Connector Wire Length	300mm (11.811inch)			
Connector Wire Gauge	24WAG			
Dimensions	40.0mm x 20.0mm x 37.0mm (1.575inch x 0.787inch x 1.457inch)			General Tolerance ±0.1mm
Weight	43.0g (1.517oz)			Excluding the weight of Horn
Bearing Type	1 Resin Bushing			-
Case Material	Engineering Plastic			-
Gear Material	4 Resin Gears			-
Gear Train Backlash	Max 0.5°			-
Horn Gear Spline	25T(Ø6.0)			-
IP-Rating	IP4X			-
Servo Amplifier Type	Analog Contorller			-



1:1 scale (Unit : mm[inch])

- This product should not be used directly on the human body for medical purposes.
- All specifications are subject to change without notice.



9001:2015  
14001:2015  
CERTIFIED



HitecRCD.com