

HITEC

HITEC
2.4GHz
G2 AFHSS

SLT
SECURE LINK TECHNOLOGY™

4096
RESOLUTION



FLASH 8

8 Channel 2.4 GHz Aircraft Computer Radio System

Before Using

It is recommended that you read this manual in its entirety to become familiar with the product and its features. Failure to operate this product properly can result in damage to property and/or cause serious injury.

Important Notices

Please note that Hitec reserves the right to make production changes during the life of our product lines that may impact the information in this manual. For the most up-to-date information on this and any other Hitec product, visit our web site at www.hitecrad.com.



Warning

This product was designed for and intended for use with hobby models designed specifically for radio control only. Hitec RCD disclaims all liability for any damages or injuries resulting from the use of this product for anything other than its intended purpose.



Warning

This radio control transmitter is not intended for use by children under 14 years of age. Adult supervision is required for any user under the age of 14.



DISPOSAL OF eWASTE

This symbol indicates that when this type of electronic device reaches the end of its service life, it cannot be disposed of with normal household waste and must be recycled. To find a recycling center near you, refer to the internet or your local phone directory for electronic waste recycling centers.

STATE OF CALIFORNIA PROPOSITION 65 WARNING:

This product contains chemicals known to the State of California to cause cancer. Use caution when handling this product and avoid exposure to any electronic components or internal assemblies.

Regulatory information

Hitec RCD Inc.
Radio Control Hobby Model Controller

Model Name: Flash 8

Operating Frequency: 2.4GHz

Power

Charger: None

Transmitter: 6.4V (2-cell LiFe Battery)

This device complies with part 15 of the FCC Rules. Operation is subject to the following two conditions:

1. This device may not cause harmful interference.
2. This device must accept any interference received, including interference that may cause undesired operation.

Table of Contents

SECTION 1

Introduction

Introduction.....6
 Safety Information.....7
 Product Support.....8
 Steps for Successfully Programming the Flash 8 Radio.....9
 System Component Specifications.....10
 Terms and Icons.....11
 Powering the Flash 8.....12
 Transmitter Controls.....13
 Main Menu.....14
 Transmitter Warnings.....14
 Maxima Series Receivers.....15
 Optima and Minima Receivers.....17
 Fail Safe and Hold Mode Setup.....21
 Telemetry System.....22
 Range Check Function.....23
 Scan Mode Function.....24
 SLT System.....25

SECTION 2

Quick Start Guides

Airplane Quick Start Guide.....26
 Helicopter Quick Start Guide.....28

SECTION 3

System Menu Programming

System Menu.....30
 Model Select Menu.....31
 Model Type Menu33
 Model Type ACRO Menu Programming.....34
 Model Type GLID Menu Programming.....35
 Model Type HELI Menu Programming.....37
 Channel Selection Menu.....38
 Trim Step.....39
 Trainer Function.....39
 Control Modes.....42
 Management Menu.....42

SECTION 4

Common Model Programming Menu

Working with the Common Model Function Menus.....45
 Servo Reverse.....46
 Sub Trims.....46
 Dual Rates.....47
 Exponentials.....48
 Switch Assignment.....48
 End Point Adjustments49
 Servo Speed50
 Programmable Mixes51
 Timers.....55
 Servo Monitors.....57
 Throttle Lock.....58

SECTION 5

ACRO and Glider Programming

Acro and Glider Programming Menu.....60
 Flight Conditions.....61
 Aileron Differentials.....63
 Elevon Mixing.....64
 V-Tail Mixing.....66
 Ailevator Mixing.....68
 Aileron to Rudder Mixing.....70
 Elevator to Camber Mixing.....72
 Camber Mixing (GLID Only).....75
 Flap Control.....78
 Landing Mix.....80
 Butterfly Mixing (GLID Only).....82
 Gyro.....85
 Throttle Cut (ACRO Only).....87
 Throttle Curve.....88

SECTION 6

Helicopter Programming

Helicopter Programming Menu.....91
 Gyro.....91
 Throttle Cut.....94
 Throttle Hold.....95
 Revolution Mixing.....96
 Swash to Throttle Mixing.....99
 Swash Mixing.....101
 Throttle Curve.....102
 Pitch Curve.....105
 Flight Conditions.....107
 Swash Ring.....109
 Throttle Lock.....110

SECTION 7

Using the Telemetry System

Working with the Sensor Menu.....111
 GPS.....112
 RPM.....112
 Temperature.....113
 Battery.....114
 Servo.....115
 Advanced.....115
 Viewing Telemetry Data.....116

APPENDIX A

Hardware Adjustments

Stick Length Adjustments.....117
 Stick Lever Tension Adjustment / Mode Change.....117

Introduction

Thank you for purchasing the Flash 8 radio by Hitec. Designed for all popular aircraft types, the Flash 8 delivers lightning fast response with its 7ms frame rate and 4096 step resolution. You can trust Hitec's bi-directional, AFHSS (Advanced Frequency Hopping Spread Spectrum) 2.4GHz technology to guide your sailplane, gas, glow or electric power plane or heli to a safe landing every flight. We are sure you will find the Flash 8 one of the easiest radios to program. Please review this entire manual to learn how to safely use your new radio. It's a good idea to keep the manual with your Flash 8 at all times.

Features

1. **Triple Protocol 2.4GHz Transmitter:** The Flash 8 can transmit using three different 2.4GHz signals.
 - a. Our original AFHSS bi-directional telemetric 2.4Ghz signal used with the Minima and Optima series receivers.
 - b. Our Low Latency G2 AFHSS 2.4GHz signal used with Maxima series receivers.
 - c. The SLT™ protocol found in many Tx-Ready aircraft. For more info visit www.Tx-Ready.com.
2. **3 in 1 Radio:** With advanced Acro, Glider and Helicopter programming you have the ability to advance your flying skills without having to upgrade your radio.
3. **Precise 4096 Resolution:** At two to four times the resolution of most transmitters, the Flash 8's 4096 step resolution gives you more precise and crisp servo movement.
4. **Backlit Graphical LCD screen:** Makes it easy to see the programming and telemetry displays.
5. **Push Button / Jog Dial Programming Interface:** So that programming the Flash 8 is a breeze.
6. **8 Assignable Switches and 2 Sliders:** Gives you plenty of choices for total control.
7. **Telemetry Capabilities with our Optima Receiver:** Keeps you informed of what's going on in your plane.
8. **DCS Port (Battery Voltage Power Out):** Powers optional accessories such as VR goggles or head tracking units.
9. **Memory for 30 Separate Models:** Powers optional accessories such as VR goggles or head tracking units.

Safety Information

Flying models can be dangerous if proper safety precautions are not followed. Here are a few critical safety suggestions to keep you and others safe.

Are you experienced?

Flying models is not an intuitive process. Most accomplished model pilots were taught by another modeler. We encourage you to seek help during your early flight experiences and, if required, during the building and radio gear installation process. Unlike some other hobbies, model airplane flying has evolved into a social event. There are approximately 2,500 model aircraft clubs in America. Friendship and help could be right around the corner. Ask your local hobby shop about clubs in your area.

Where to Fly

Having enough land for your own model airport is rare. Most of us fly at club administrated model fields. The local ball field can be tempting but rarely has the space needed and your liability is high should you damage property or hurt an innocent bystander. We recommend you fly at a sanctioned model aircraft field.

Join the AMA

In America, the Academy of Model Aeronautics (AMA) is an organization of model enthusiasts that provides resources and insurance to modelers. The AMA also lobbies the Government concerning legislation that impacts modelers. Visit their web site for more information at www.modelaircraft.org.

Academy of Model Aeronautics
5151 East Memorial Drive
Muncie, Indiana 47302
Toll Free: 800 435-9262

Fundamental Guidelines for Safe Flying

1. Model aircraft can be dangerous when operated or maintained improperly.
2. DO NOT fly over people or personal property.
3. DO NOT fly in adverse weather conditions or high winds.
4. The equipment we use in the R/C hobby is sensitive electronic gear. Have receivers checked after a crash before using them in another aircraft.
5. DO NOT fly under the influence of alcohol or drugs or if you are feeling ill.
6. DO NOT fly near power lines or transmission towers.
7. If available use the Fail-Safe function to lower the throttle in case of a signal "lock-out"
8. DO NOT fly alone.

Safety Information Regarding Your Radio System

1. Make sure you do a range check before flying. If it does not range check satisfactorily, DO NOT fly.
2. Know the condition of your batteries. Make sure they are sufficiently charged.
3. Make sure all control surfaces respond correctly to the input from the transmitter.
4. Be sure that the throttle is off when turning on your airplane.
5. Always turn your transmitter on first and turn it off last.
6. If the controls don't respond properly during flight, land immediately.

Product Support

Flash 8 Programming Support

While every attempt was made by the Flash 8's developers to make the software interface easy and logical, most users will require programming help at some point. There are several "get help" options available to you.

Hitec Customer Service

Help is available from the Hitec office through phone support and e-mail inquiries. The U.S. office is generally open Monday thru Friday, AM 8:00 to PM 4:30 PST. These hours and days may vary by season. Every attempt is made to answer every incoming service call, but should you get voice mail, leave your name and number and a staff member will return your call.

Hitec Web Site

Make plans to visit the Hitec web site on a regular basis at www.hitecrd.com. There you will find specs and other information about the entire Hitec product line, and soon our FAQ pages will hold valuable information about the Flash 8.

The On-Line Community

One of the benefits of the extensive R/C online community is the vast wealth of archived knowledge available. Hitec sponsors forums on most of the popular R/C web sites where a Hitec staff member or representative answers all manner of product related questions. Bringing together strangers with common interests is proving to be one of the greatest gifts of the internet. If past history is any guide to the future, we are certain forums will be started about the Flash 8.

Warranty and Non-Warranty Service

All Hitec products carry a two year from date-of-purchase warranty against manufacturer's defects. Our trained and professional service representative will determine if the item will be repaired or replaced. To provide all the necessary information we need to administer your repair, visit our web site at www.hitecrd.com to download the repair form. Complete the form and send in your item for repair.

Hitec Service
12115 Paine St.
Poway CA 92064
(858)748-6948
service@hitecrd.com

Steps for Successfully Programming the Flash 8 Radio

Using this Manual

This manual is a valuable resource detailing the programming and operation methods of the Flash 8 radio. The Flash 8 manual is divided into seven distinct sections:

1. Introductory material that is mandatory reading. This is where you will learn detailed information that will be invaluable to the successful programming of the Flash 8.
2. Airplane/Glider and Helicopter quick start guides.
3. System menu programming common to all models.
4. Model Menu programming common to all models.
5. Model menu programming common to all Airplane and Glider models.
6. Model menu programming specific to Helicopter models.
7. Using the Flash 8's Telemetry Capabilities.

Warning, Caution, Note and Tip Boxes

Throughout the manual, you will see important information inside a labeled box. Take note of this important information.



Warning: This icon alerts you to warnings that relate to your safety and help you avoid causing damage to your equipment.

Caution: This icon indicates that careful attention must be paid.

Tip: This icon points out valuable technical information.

Note: This icon indicates that further information is available.

User Interface

User Interface

The Flash 8 utilizes a jog dial/push button and a back button to access the various functions and input settings in the radio. The jog dial/push button is used to scroll through screens and programming features. Press the jog dial to enter a menu, activate or confirm a setting. Pressing the back button takes you to the previous screen or function. Pressing both the jog dial and back buttons takes you to the System Menu where most of the initial aircraft setup takes place.

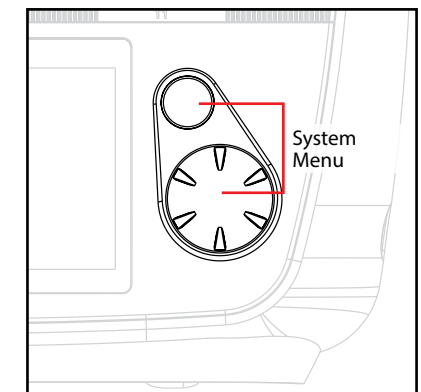
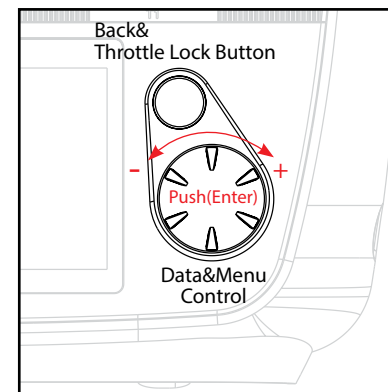

Quick Start Guides

Quick Start Guides

We recommend that you read the introductory information in section one, then proceed to one of the quick start guides and start programming. After following along with the quick start guide you will have a feel for the way the Flash 8 programming is laid out. We encourage you to set up a few aircraft before you fly the Flash 8. It will be time well spent and help acquaint you with the programming process.

System Component Specifications

Flash 8 Transmitter

Modulation: 2.4GHz

Optima (AFHSS Bidirectional): For use with the Optima series telemetry capable receivers.

Minima (AFHSS Single-direction): For use with the Minima series receivers.

Maxima (AFHSS Single-direction): For use with the High response low latency Maxima series receivers.

Power Supply: 2-cell 6.4v 1400mAh LiFe Battery.

Current Drain: 300 mA.

Available Receivers

Optima Series 2.4GHz Receivers

Model	Size	Weight	Stock Number
Optima 6 Lite	1.76 x 1.11 x 0.29in (44.9 x 18.4 x 7.40mm)	0.33oz (9.4g)	29438
Optima 6	1.81 x 0.82 x 0.47in (46.1 x 21.3 x 12.1mm)	0.52oz (15g)	28410
Optima 7	2.20 x 0.79 x 0.43in (56.9 x 20.8 x 11.6mm)	0.60oz (17g)	28414
Optima 9	1.85 x 1.14 x 0.59in (47.7 x 29.1 x 15.5mm)	0.77oz (22g)	28425
Optima SL	1.85 x 1.14 x 0.59in (47.7 x 29.1 x 15.5mm)	0.77oz (22g)	27224

Operating Voltage: 3.7~8.4V from a receiver battery or BEC circuit from an Electronic Speed Control
4.8~35v Using SPC Function

Current Drain: 30mA

Maxima Series 2.4GHz Receivers

Model	Size	Weight	Stock Number
Maxima 6	1.29 x 0.81 x 0.42in (33 x 20.8 x 10.7mm)	0.22oz (6.4g)	27524
Maxima 9	1.45 x 0.97 x 0.57in (37 x 24.4 x 14.6mm)	0.28oz (8.1g)	27525

Operating Voltage: 3.7~8.4V from a receiver battery or BEC circuit from an Electronic Speed Control

Current Drain: 30mA

Minima Series 2.4GHz Receivers

Model	Size	Weight	Stock Number
Minima 6 T	1.19 x 0.81 x 0.27in (30.4 x 20.8 x 7.1mm)	0.22oz (6.5g)	26610
Minima 6 E	1.24 x 0.81 x 0.42in (31.7 x 20.8 x 10.9mm)	0.28oz (8.1g)	26612
Minima 6 Lite	1.22 x 0.77 x 0.33in (31.2 x 19.5 x 8.5mm)	0.14oz (4g)	26614
Minima 6S	1.19 x 0.81 x 0.27in (30.4 x 20.8 x 7.1mm)	0.19oz (5.4g)	26615

Operating Voltage: 3.7~8.4V from a receiver battery or BEC circuit from an Electronic Speed Control

Current Drain: 30mA

Terms and Icons

Glossary of Terms

AFHSS 2.4GHz Signal: Hitec's 2.4GHz R/C signal protocol. Adaptive Frequency Hopping Spread Spectrum.

Telemetry: Data signal from the model, transmitted to the transmitter.

Range Check: A ground check of the signal strength between the transmitter and receiver done before flying.

Link (ID Setting): Link or "binding" a 2.4GHz receiver to its master transmitter.

HPP-22 PC Interface: PC interface accessory for storing model memories and updating firmware.

Icon Identification

MODEL: The model menu contains the model programming for the active model.

ACRO: Menu for fixed wing, glow, gas and some electric models.

GLID: Menu for gliders and some electric models.

HELI: Menu for rotary wing aircraft.

AILE: Aileron for fixed wing menus and the "roll" swash input for helis.

ELEV: Elevator for fixed wing menus and the "pitch" swash input for helis.

RUDD: Rudder for fixed wing menus and the "yaw", or tail rotor input for helis.

INH: Inhibit is used to "turn off" a function.

ACT: Active, "turns on" a function.

NULL: "No switch" selected, the function or feature will be "on" all the time.

AUX: An "open" channel, without a control assigned to it.

J1: Right gimbal, up and down control.

J2: Right gimbal, side to side control

J3: Left gimbal, up and down control.

J4: Left gimbal side to side control.

T1: J1 control trim.

T2: J2 control trim.

T3: J3 control trim.

T4: J4 control trim.

LT: Non set digital trim.

RT: Non set digital trim.

RS: Right slider control.

LS: Left slider control.

Multi-I/O: Port File sharing, trainer and PC interface mode.

Powering the Flash 8

The Flash 8 operates on 4.8~ 8.4Volts DC. and can use a 2 cell Li-Fe, Li-Po and Li-ION type battery or 4 cell NiMH or Alkaline battery.



Make sure you use a charger suitable for the battery pack you are using. It is recommended that you remove the battery from the transmitter when charging it.

Selecting the Battery Type

The standard battery type of Flash 8 is a 2 cell Li-Fe that has a 6.0V setting for the low voltage alarm. If you choose to use a different type of battery, you must select the battery type in the System Management menu. The preset warning thresholds for each type are:

- LiFe 6.0 Volts
- NiMH or NiCd 4.3 Volts
- LiPo 7.0 Volts
- Alkaline 4.0 Volts

Charging the Supplied 2 Cell LiFe Battery

Make sure to fully charge the battery when using your Flash 8 radio for the first time or after it has been stored for an extended period.

1. Make sure the radio is turned off.
2. Connect the supplied Charger to an AC outlet and then to the charge port on the side of the radio as shown in the illustration. The Red LED light shows that the battery is currently charging.
3. When the light changes to green the battery is fully charged.



The supplied Hitec LiFe battery has a built-in protection circuit. This circuit could be damaged if you attempted to perform a high current quick charge or discharge. The supplied battery should only be charged with the supplied charger. The use of any other charger will void the warranty.

Power Meter

On the home screen of the Flash 8, you can visually see the voltage reading as well as a bar indicating the amount of power left in the battery.

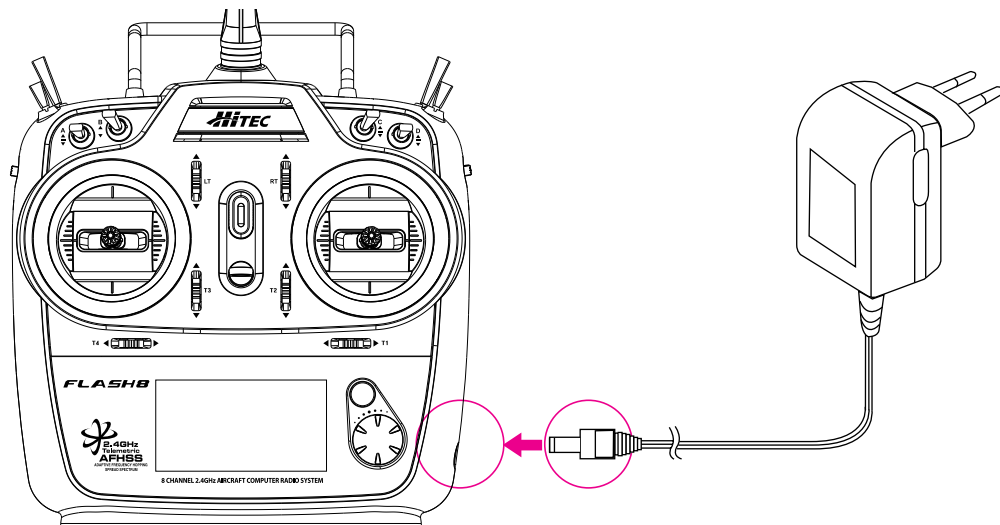

Transmitter Controls

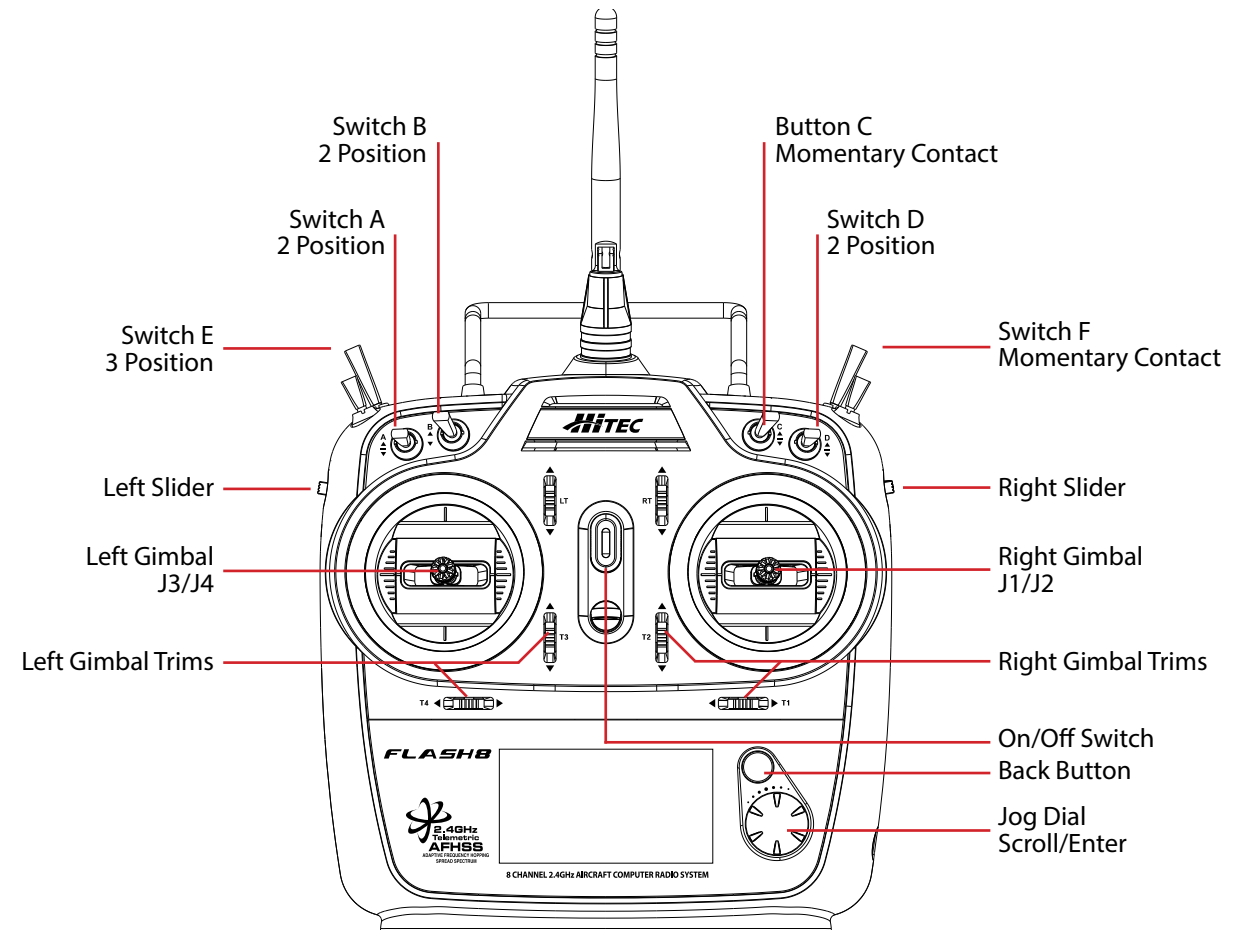

Main Menu

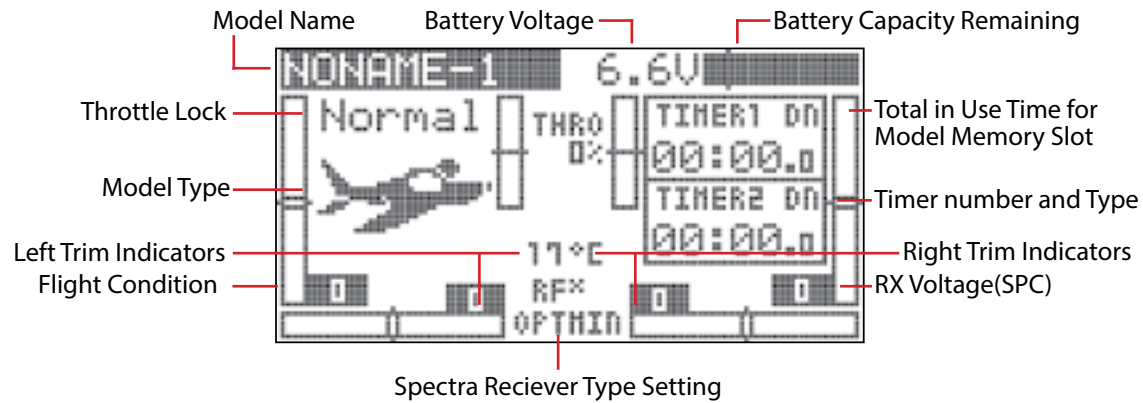

Tip From the main menu, you can quickly access certain settings by scrolling to them and pressing the jog dial.

Transmitter Warnings

The Flash 8 has a few warning alarms that you should be aware of.

Start Up Warnings

If the transmitter continuously beeps and the logo light flashes red and blue immediately after turning on the power, read the warning message displayed on the screen. The Flash 8 will not transmit a radio signal until all start-up warnings have been corrected. If UI Feedback is turned off, the transmitter will not beep during active warnings. The logo light will flash red and blue regardless of the UI Feedback setting. (See Section Three: System Menu Programming for instructions on configuring UI Feedback.)

- High Throttle

If the throttle is positioned above idle during the system "boot-up to transmit" process, a warning beep will occur and the following warning screen will be displayed.

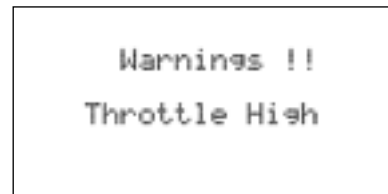

- Condition on Warning

If you have flight conditions and other mixing programmed for the active model and they are switched "on" during the "boot-up to transmit" process, a warning sound will occur and the following warning screen will be displayed.

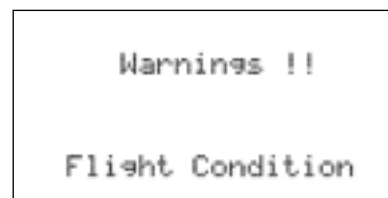

In Flight Warnings

If the transmitter should start a continuous beeping during flight, land immediately and evaluate the cause of the warning. There are two warnings that may occur in flight.

- Low Transmitter Battery Warning

When the transmitter battery power falls to a critically low level, a warning sound will occur.

- Low Aircraft Battery Warning

When using the Optima series of receivers and the on-board battery or the battery connected to the SPC port is critically low, your transmitter will start beeping warning you that you should land immediately. This feature does not occur when using single direction receivers such as the Maxima and Minima series of receivers.

Maxima Series Receivers



The Maxima series is designed for use with G2 AFHSS radios such as the Aurora 9X and Flash series. USE ONLY Digital SERVOS with the Maxima receivers. Analog servos cannot be used with the Maxima series receivers.

MAXIMA 6

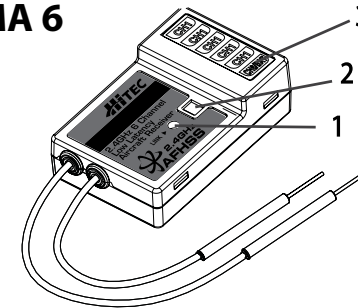

MAXIMA 9

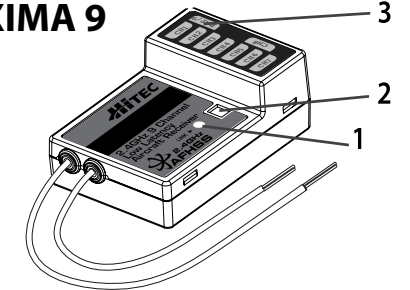

- 1. Function Button:** Used for binding the receiver to the Flash 8 and entering the FAIL-SAFE or Hold feature.
- 2. Dual LED Status Indicator:** Indicates the set-up process codes and current status of the receiver.
- 3. Channel Output and Battery Input Ports:** The ports for battery power input and servos, gyros and other accessories' output ports are located at the side end of the Maxima receivers.
- 4. Low Battery Warning:** If the receiver's battery levels fall below 3.6V, the RED LED will flash.
- 5. FAIL-SAFE/Hold Mode Selectable:** Servos and other accessories position can be set with a FAIL-SAFE point if power to the receiver is lost.

Maxima Series Receiver Antenna Installation

The Maxima receiver series antenna system was created to provide the optimum signal capture capability. Our two antennas must be installed properly. Refer to the illustration below.

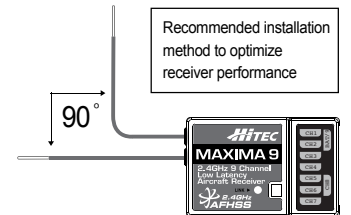
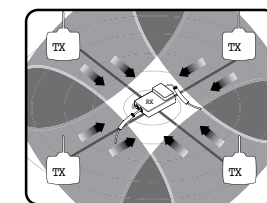

Maxima Series Receiver Connection Diagrams

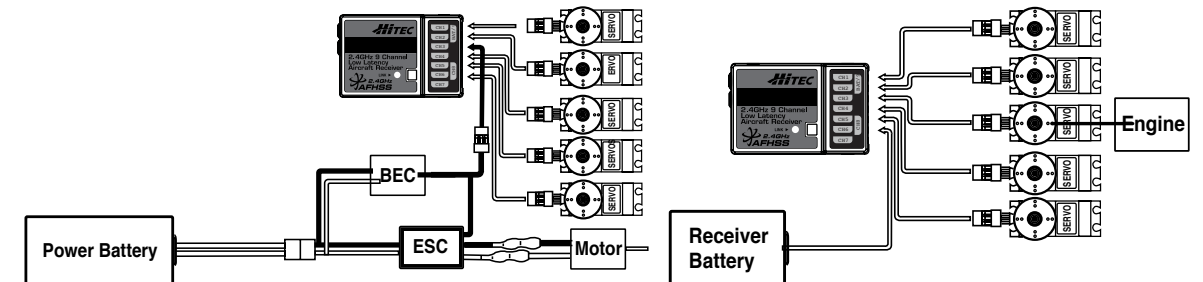

Electric powered aircraft with Electronic Speed Control
Use this method on electric planes using ESCs providing power to the receiver and servo functions.

Glow, gas or electric powered aircraft using a separate receiver battery supply.
Follow this connection diagram when using a regulated Li-Po, or 4.8 to 6V receiver battery.

Maxima Series Receiver Link (ID-Setting or Bind)

Your Hitec AFHSS system uses a communication protocol that links and binds the Hitec 2.4GHz receiver to your transmitter. Once the receiver and transmitter are “bound”, no other transmitter can interfere with your receiver during its operation. In the case of multiple model memory transmitters, you can bind as many Hitec 2.4GHz receivers to your transmitter, one per model memory as necessary. Each transmitter and receiver set is paired at the factory for your convenience.

- 1** Turn on the transmitter by holding down the power button momentarily. (To turn off the transmitter, press and hold the power button for approximately 3 seconds.)

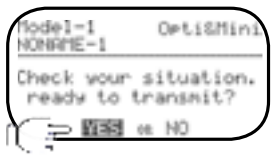

- 2** Press the jog dial and back button simultaneously to enter the System Menu list. From here scroll to the “SPECTRA” function and press the jog dial to enter the Spectra setup menu.

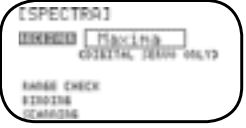
- 3** Press the jog dial to activate the receiver selection and scroll to the “Maxima” receiver.



Press the jog dial to save your setting. When prompted to change the receiver type, select “YES” and press the jog dial to confirm your choice.



- 4** Now when prompted if you are “Ready to Transmit” select “Yes” and push the jog dial to confirm your response. In the receiver selection screen, scroll to “BINDING” and press the jog dial to enter the binding screen.

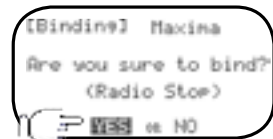

Select “yes” if you would like to proceed with the binding process.

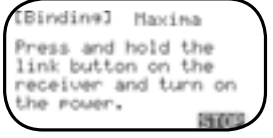
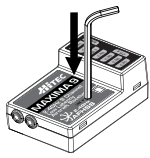
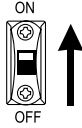
- 5** Press and hold the link button on the Receiver and turn on the power.

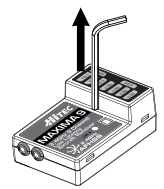

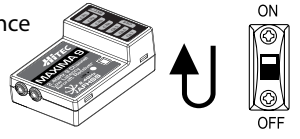

- 6** Release the link button. Both RED and BLUE LEDs will be blinking rapidly to find the transmitter's signal.

- 7** When the LED stops blinking, press the jog dial to get to the next screen. The blue LED will glow solid.
- 8** Turn the power to the receiver off, then back on. Check for a solid blue LED light. Once it's on, press the jog dial to FINISH the binding process. Make sure all functions are working properly before flying your model.

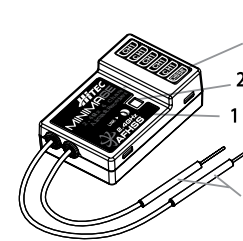

Optima and Minima Series Receivers

The following information contains the complete directions on how to use the Optima and Minima series receivers (version 3.00(0)). We encourage you to review this information before using these products.



MINIMA 6S & MINIMA 6T

(6T output block is on top)

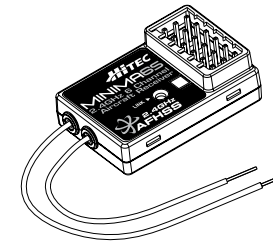

MINIMA 6S

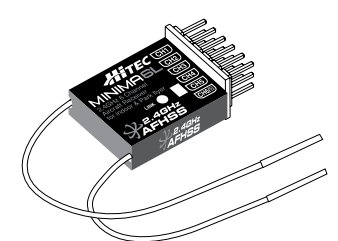

MINIMA 6L

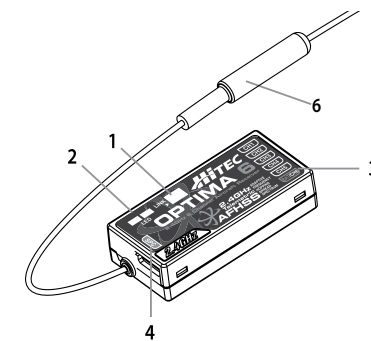

OPTIMA 6 & OPTIMA 6 LITE

(6L utilizes a soft case and exposed output block)

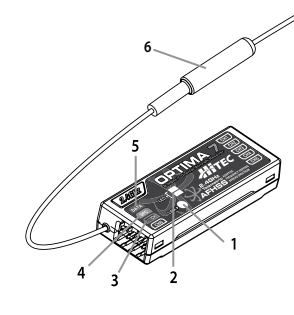

OPTIMA 7

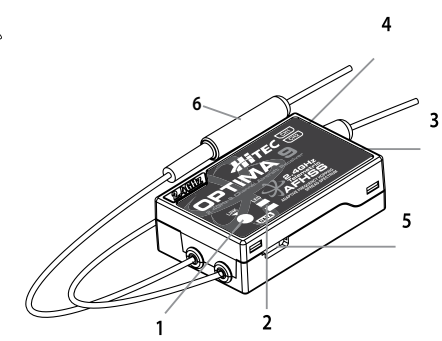

OPTIMA 9

- 1. Function Button:** Used for binding the receiver to a module or Hitec 2.4 built-in transmitters, entering the FAIL-SAFE or Hold feature.
- 2. Dual LED: Status Indicator:** Indicates the set-up process codes and current status of the receiver.
- 3. Channel Output and Battery Input Ports:** The ports for battery power input and servos, gyros and other accessories' output ports are located at the side.
- 4. SPC (Supplementary Power Connection)*:** Power the Optima and Minima receivers function with up to a 35V electric aircraft motor battery.
- 5. Telemetry Sensor and Data Port*:** A three pin servo plug connector port is featured on the Optima 7 and Optima 9 (Optima 6 is not applicable.) Using the HPP-22 PC interface accessory, this port serves to facilitate upgrading the device's software and interfacing the optional onboard sensor station.
- 6. BODA (Boosted Omni Directional Antenna) System*:** Hitec's exclusive 2.4GHz BODA System will show you another way of using our 2.4GHz systems. The single Omni-directional antenna booster makes it much easier to install the 2.4GHz antenna. Intensive tests have proven that the single BODA system in our 6 & 7 channel systems is better than or equal to our competitor's dual antenna systems while our Optima 9 receiver features a dual BODA system to give the added security that larger models need. Installation is easy and simple, insert the antenna into the supported antenna holder and stick it to the desired spot you wish to install.

Optima and Minima Series Receivers cont.

Compatibility:

The OPTIMA & MINIMA receivers are compatible with transmitters using the Hitec AFHSS 2.4 GHz system, such as, Spectra 2.4 module or dedicated built-in module AFHSS 2.4 Hitec transmitters.

FAIL-SAFE/Hold Mode Selectable:

Servos and other accessories can be set with a FAIL-SAFE point if power to the receiver is lost.

Jumper*:

The jumper is installed at the factory and is used when the receiver is powered by an electronic speed control, a commercially available B.E.C. (battery eliminator circuit), dedicated 4.8 to 6V. NiMH battery pack, or regulated Li-Po battery. The jumper is removed when the receiver is powered using the SPC feature.

*These functions/ features are only for OPTIMA series receivers.

Common Receiver Connection Diagrams

Electric powered aircraft with Electronic Speed Control: This configuration is appropriate for electric planes using ESCs providing power to the receiver and servo functions.

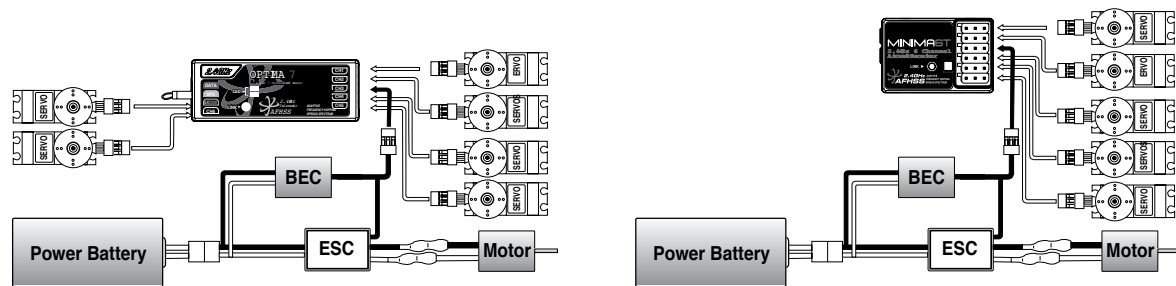

Glow, gas or electric powered aircraft using a separate receiver battery supply: Follow this connection diagram when using a regulated Li-Po, or 4.8 to 6V receiver battery.

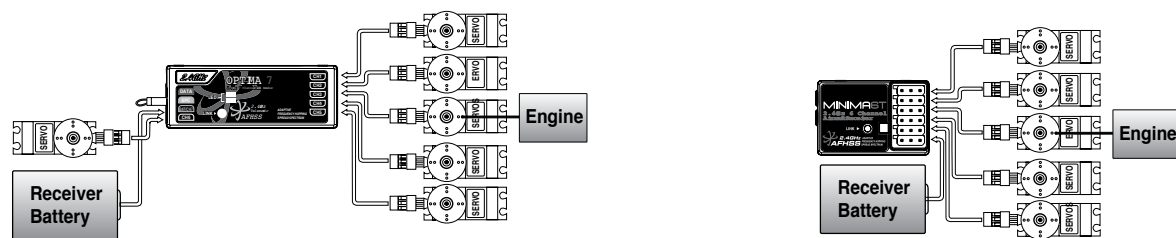

Optima and Minima Series Receiver Link (ID-Setting or Bind)

Your Hitec AFHSS system uses a communication protocol that links and binds the Hitec 2.4GHz receiver to your transmitter. Once the receiver and transmitter are "bound", no other transmitter can interfere.

- 1** Turn on the transmitter and select "Yes" to the "Ready to Transmit" prompt by pressing the jog dial.
- 2** Press the jog dial and back button simultaneously to enter the System Menu list. From here scroll to the SPECTRA function and press the jog dial to enter the Spectra setup menu.
- 3** Press the jog dial to activate the receiver selection and scroll to the "Opti&Mini" receiver.

Press the jog dial to save your setting. When prompted to change the receiver type select "Yes" and press the jog dial to confirm your choice.
- 4** Back at the receiver selection screen, scroll to BINDING and press the jog dial to enter the binding screen.

Select the type of receiver you are using, either Optima or Minima, and push the jog dial to confirm your selection.
- | OPTIMA | MINIMA (MAXIMA) |
|---------------------------|-----------------|
| Select "Yes" for binding. | |
| | |
- 6** Press and hold the link button on the Receiver and turn on the power.
- 7** Release the link button.

Release the Link button, both RED and BLUE LEDs will be blinking rapidly to find the transmitter's signal.

Optima and Minima Series Receiver Link (ID-Setting or Bind) cont.

8

When the binding process is completed, it automatically goes to the finish screen. (The BLUE and RED LEDs will be solidly on)

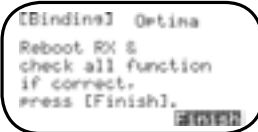

When the LED stops blinking, press the jog dial to get to the next screen. The blue LED will glow solid.



9

Turn the power to the receiver off, then back on. Check for a solid blue LED light. Once on, press the jog dial to FINISH the binding process. Make sure all functions are working properly before flying your model.

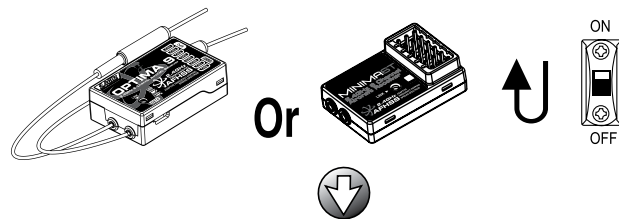

If all functions work well, press the Finish icon on the screen to finish binding.

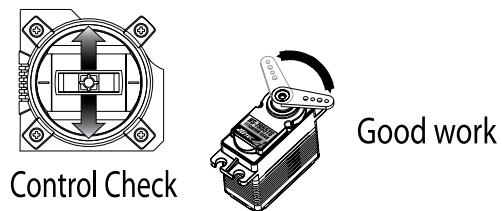

If any function is not working as described, please go back to step 6 and repeat the binding again.

FAIL-SAFE and Hold Mode Setup

If the FAIL-SAFE function is set up and used properly but the receiver signal is somehow interrupted, the servos will move to your previously stored FAIL-SAFE setup. If you do not activate the FAIL-SAFE function, the signal is switched off after the HOLD period of 1 sec. This means that the servos become "soft" and remain in their last commanded position under no load (this may equate to full-throttle!) until a valid signal is picked up again. In the interest of safety, we recommend that FAIL-SAFE should always be activated, and the FAIL-SAFE settings should be selected so as to bring the model to a non-critical situation (e.g. motor idle / electric motor OFF, control surfaces neutral, airbrakes extended, aero-tow release open, etc.).

1

Switch on both. Wait for the system to boot and you have control over the model.



2

Press and hold the button on the receiver until LED turns off (approx. 6 second)



3

Release the button. After 2 seconds both red and blue LEDs blink alternately. The receiver will count 5 seconds. During that time, move all the transmitter sticks and other controls to the desired FAIL-SAFE positions (e.g. motor idle, control surfaces neutral), and hold until the blinking stops.

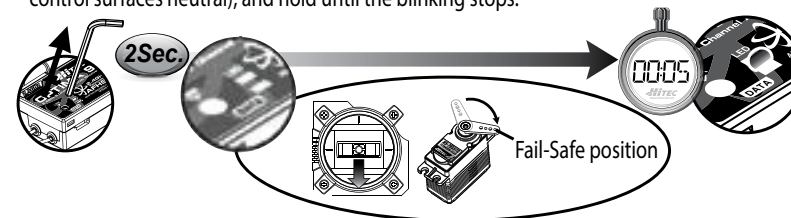

4

When the blinking stops, the system will temporarily remember the FAIL-SAFE position, turn off the system to save and exit.

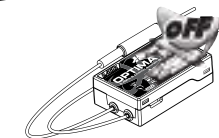

Testing the FAIL-SAFE Setting

Move the sticks to positions other than the FAIL-SAFE settings, and then switch off the transmitter. The servos should now move to the FAIL-SAFE positions previously stored after the one second HOLD period.

How to turn FAIL-SAFE Off and reactivate the Hold Mode

- Switch on the transmitter, then the receiver. Wait for the system to boot and you have control over the model.
- Press and hold the receiver function button for 6 seconds and release it. After 2 seconds, the red and blue LEDs will blink rapidly.
- Immediately press the receiver function button once.
- FAIL-SAFE Mode is now deactivated and HOLD mode is activated.
- Turn the transmitter off, then the receiver off.
- Turn the system back on to use it.

Telemetry System

The Hitec Spectra 2.4 System and Optima Series receivers feature full telemetry capabilities (except Optima 6) and include a Low Receiver Battery Warning as a basic function.

Functions (Available with Optima 7 and 9):

Hitec offers a wide variety of telemetry sensors designed to work with both fuel and electric powered aircraft. Check our website at www.hitecrd.com for the latest available telemetry accessories.



- The telemetry function is applicable for OPTIMA series receivers only.



- The actual battery voltage level could be different.
- When the 2.4GHz system and High Voltage servos are used together, we strongly recommend using fully charged large capacity battery packs.

Range Check Function

It is critical that before each flight session, you perform a range check that confirms that the signal between the receiver and transmitter is strong. To do a range check, use a power-down mode to reduce the transmitter signal strength. During this power-down mode, you should walk away from the secured aircraft while carrying the transmitter to a distance of approx. 30 meters, to test the effective range. The model should exhibit no signs of signal loss during the range check.

1. Turn on the transmitter and select "Yes" from the "Ready to Transmit" prompt by pressing the jog dial.

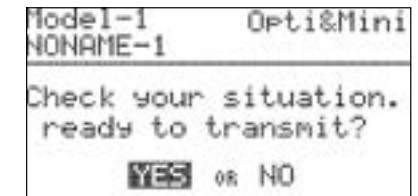

2. Press the jog dial and back button simultaneously to enter the System Menu list. From here, scroll to the SPECTRA function and press the jog dial to enter the Spectra setup menu.



3. Scroll to the RANGE CHECK and push the jog dial to enter the range check function.

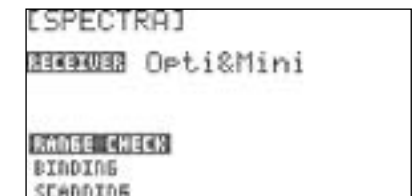

4. If you are sure you want to proceed with the range check, select "Yes" and press the jog dial to continue.

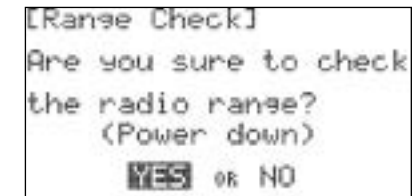

5. Walk away from the secured aircraft carrying the transmitter to a distance of approx. 30 meters, to test the effective range. Once you have completed the range check, push the jog dial to end the range check.



Scan Mode

In Scan Mode the transmitter and receiver will scan all available channels every time you turn it on. It will then choose the cleanest frequencies to use. Scan Mode is preferable to use when flying in a crowded 2.4GHz environment.

1. Turn on the transmitter and select "Yes" to the "Ready to Transmit" prompt by pressing the jog dial.

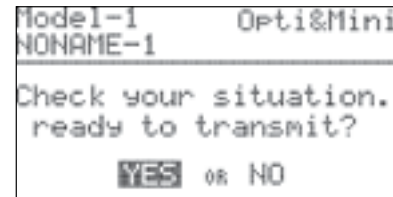

2. Press the jog dial and back button simultaneously to enter the System Menu list. From here scroll to the SPECTRA function and press the jog dial to enter the Spectra setup menu.



3. Scroll to the Scanning selection and push the jog dial to enter the Scanning function.

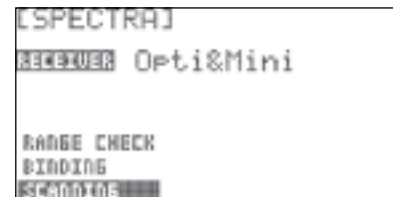

4. If you are sure you want to proceed with the Scanning, select "Yes" and press the jog dial to continue.

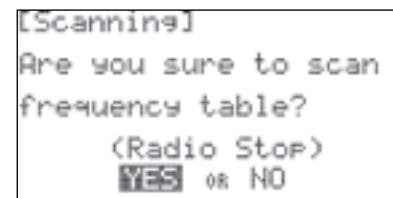

5. If Scan Mode link is successful, you will be prompted to reboot the receiver.

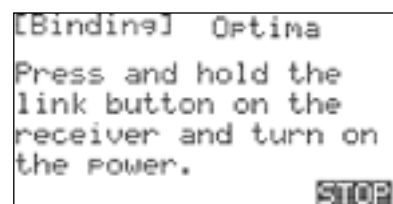

6. Check to see that all functions are operating correctly. If they do, press Finish. You now have successfully bound your receiver in scan mode.

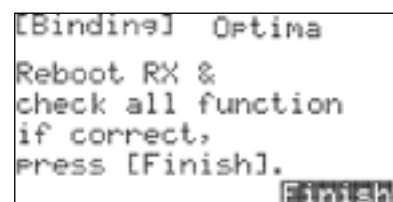

SLT Technology

In addition to our proprietary AFHSS technology the Flash 8 has the ability to transmit using Secure Link Technology (SLT). This allows you to fly the numerous Tx-Ready models available on the market. For more information visit Tx-Ready.com for models utilizing this technology. Follow these instructions to utilize SLT with your Flash 8.

1. Turn on the transmitter and select "Yes" to the "Ready to Transmit" prompt by pressing the jog dial.

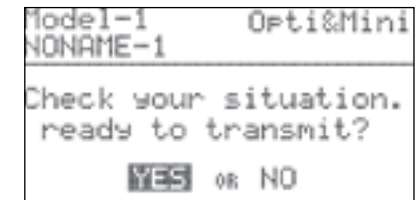

2. Press the jog dial and back button simultaneously to enter the System Menu list. From here scroll to the SPECTRA function and press the jog dial to enter the Spectra setup menu.



3. Press the jog dial to activate the receiver selection and scroll to the "SLT" receiver.

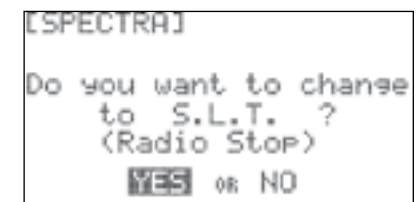

4. When prompted with the "ready to transmit?" message, highlight "YES" and press the jog dial.

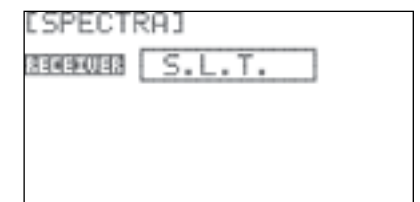

5. At the "Ready to Transmit?" prompt, highlight "YES" and press the jog dial to confirm your selection.

SLT Binding

The following procedure is for binding typical SLT receivers to the Flash 8. These methods may vary from manufacturer to manufacturer. Check your receiver manual for any variances to these instructions.

1. Turn on the transmitter and select "Yes" from the "Ready to Transmit" prompt by pressing the jog dial.
2. Apply power to the Receiver.
3. If the receiver LED flashes once and then stays on, the receiver is already linked to the transmitter and you can skip to the next section. Otherwise, insert a small diameter screwdriver into the hole marked "LINK" or "BIND" on the receiver and press the button until the LED on the receiver glows red and then turns off after about one second.
4. Release the "LINK" or "BIND" button.
5. Make sure all functions are working properly before flying your model.

Firmware Updates

Firmware updates can be loaded to the Flash 8 with a Hitec HPP-22 PC Interface module. The Flash 8 should be connected to the HPP-22 through the transmitter's trainer port using the connector included with the interface module. Follow the HPP-22 manual to complete the firmware update.

Airplane Quick Start Guide

The following information is designed to guide you through a simple setup of a standard sport plane or unpowered glider. The operations shown during this exercise will help you understand many of the basic programming steps used by the Flash 8.



If you are setting up a powered or un-powered glider, we will be programming your plane into the ACRO menu for this exercise. Later you can explore the functions found in the GLID menus.

Channel Assignments for a Simple Powered Plane with One or Two Aileron Servos:

- Channel 1 - Aileron
- Channel 2 - Elevator
- Channel 3 - Throttle
- Channel 4 - Rudder
- Channel 5 - Aileron #2 (if used)

Channel Assignments for a Simple Un-Powered Glider:

- Channel 1 - Aileron (plug rudder or aileron servo in Ch. #1)
- Channel 2 - Elevator
- Channel 3 - Aileron #2 (if used)
- Channel 4 - Rudder

This exercise assumes two things:

1. That you have already installed the servos in your aircraft.
2. That you bound (linked) the receiver to your transmitter.



For safety reasons, remove the propeller(s) from electric aircraft during radio system setup.

1. Turn on the transmitter by pressing the power button momentarily. Do not turn on the airplane. To turn off the transmitter, press and hold the power button for approximately 3 seconds.
2. When prompted if you are "Ready to Transmit" select "No".
3. Press the jog dial and back button simultaneously to enter the System Menu list.
4. From the System Menu list highlight "MDL. SEL" and press the jog dial to enter the model selection menu.

5. Select the first default model (NONAME-1) and press the jog dial to bring up the model maintenance prompts. Select "NEW" to create a new model.

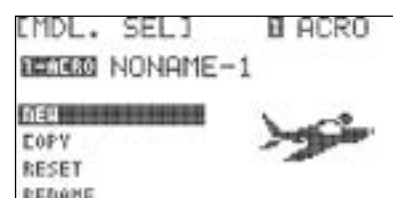
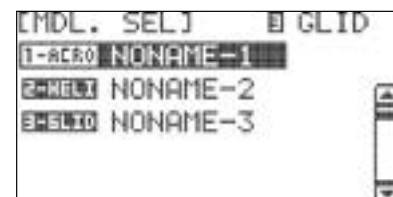
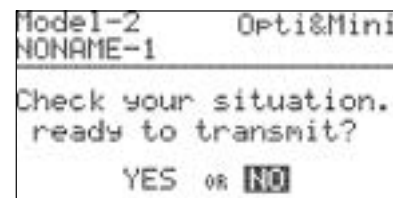

Airplane Quick Start Guide cont.



We are programming a new model into the model memory slot number two, not the model memory slot one. For the purpose of this exercise it will ensure a fresh model memory with no existing programming.

6. When asked to create a new model select "Yes." This will bring up the Model Type screen.

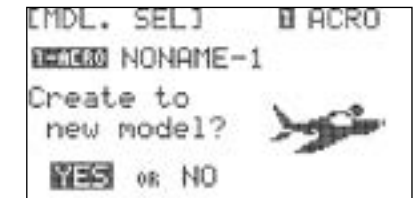

Scroll to "ACRO" and press the jog dial to confirm this selection.

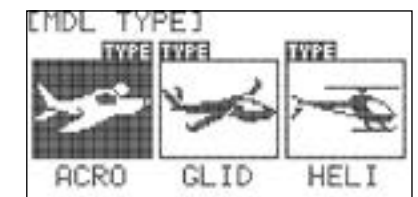

Now scroll to "wing" and press the jog dial to activate the choices. If you have 1 aileron servo, select 1AILE. If your plane has two aileron servos, select 2AILE. Press the jog dial once to confirm your selection.

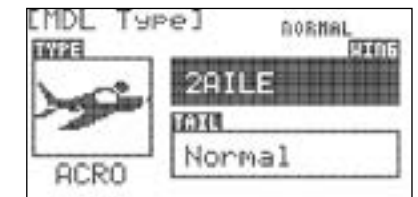

Depending on what you select here, and for the following menu choices, the radio will automatically optimize the functions for your choices. In other words, if you select a wing type without flaps, there will be no flap function control in that model memory's programming selection.

7. Scroll to "TAIL" and press the jog dial to activate the choices. Select "Normal" and press the jog dial once to confirm your entry.

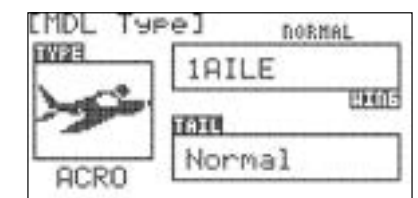

8. Now press the back button once. You will be prompted to choose the receiver type. Press the jog dial once to activate the receiver selections. Scroll to the receiver you have in your aircraft. Press the jog dial once to confirm your receiver selection.

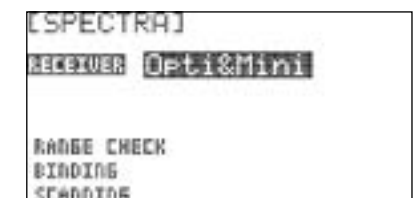

Airplane Quick Start Guide cont.



Note

If your receiver is not bound/linked to your transmitter you will need to follow the procedures on page 16 to do so.

9. Turn your transmitter off and then back on. When prompted to transmit, this time select "Yes." Power up the model and verify that all control surfaces move in the proper direction. If control directions must be reversed, or a more complex setup is needed, refer to sections 4 and 5 for more detailed programming instructions. You are now ready to fly a simple airplane model with basic settings.

Helicopter Quick Start Guide

The following information is designed to guide you through a simple setup of a basic 120° cyclic collective pitch mixing (CCPM) helicopter with a fly bar. The operations shown during this exercise will help you understand many of the basic programming steps used by the Flash 8 when programming a basic helicopter setup.

Channel Assignments

- Channel 1 – Roll Cyclic / Aileron
- Channel 2 – Pitch Cyclic / Elevator
- Channel 3 – Throttle
- Channel 4 – Tail Rotor Pitch / Rudder
- Channel 5 – Gyro Function
- Channel 6 – Collective Pitch

1. Turn on the transmitter by pressing the power button momentarily. Do not turn on the helicopter.

2. When prompted if you are "Ready to Transmit" select "No."

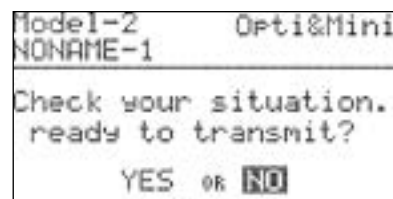

3. Press the jog dial and back button simultaneously to enter the System Menu list.



4. From the System Menu list choose MDL.SEL to enter the model selection menu.

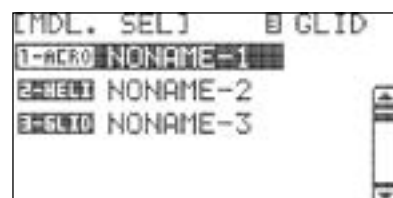

Helicopter Quick Start Guide cont.

5. Select the first default model (NONAME-1) and press the jog dial to bring up the model maintenance prompts. Select "NEW" to create a new model.

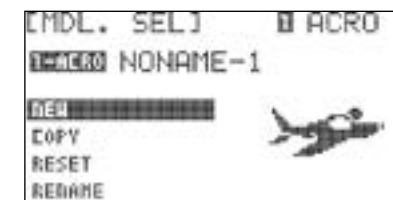

Note

We are programming a new model into the model memory slot number two, not the model memory slot one. For the purpose of this exercise it will ensure a fresh model memory with no existing programming.

6. When asked to create a new model select "Yes." This will bring up the Model Type screen.

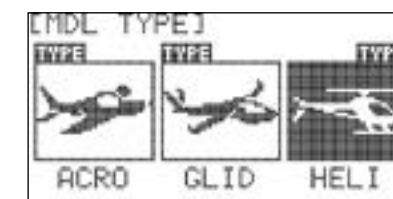

Scroll to select HELI to advance to Swash Type. Scroll to Swash Type and press the jog dial to activate the choices.

7. Scroll through the Swash Type entries until you see 120° 3-SERVO. Press the jog dial to confirm your entry.

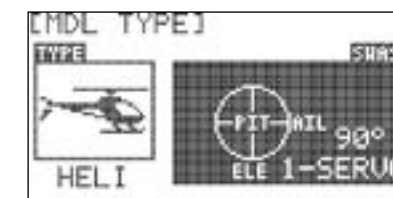

8. Now press the back button once. You will be prompted to choose the receiver type. Press the jog dial once to activate the receiver selections and scroll to the receiver you have in your aircraft. Press the jog dial once to confirm your receiver selection. If your receiver is not bound/linked to your transmitter you will need to follow the procedures on pages XX-XX to do so.

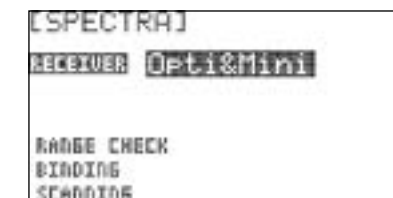

9. Turn your transmitter off and then back on. When prompted to transmit, this time select "Yes." Power up the model and verify that all control surfaces move in the proper direction. If control directions must be reversed, or a more complex setup is needed, refer to sections 4 and 5 for more detailed programming instructions. You are now ready to fly a simple helicopter with basic settings.

System Menu

There are two primary menus in the Flash 8 programming structure: the System Function Menu, and the Model Function Menu. The first menu we will explore will be the System Menu. This menu has all the common programming functions that are available for ACRO, GLID and HELI models. There are also numerous options for customizing the operating characteristics of the Flash 8 transmitter.



If you have not already programmed a model with the preceding quick start guide, we encourage you to do so before tackling the System and Model programming sections of the manual.

The Model Select menu can be accessed two different ways. One method is to highlight the model name in the main menu and press the jog dial button. The other method is to select "MDL. SEL" from the System Menu. **From the System Menu you can program the following features:**

MDL.SEL: Model Select menu

SELECT: Select an existing model

NEW: Create a new model

COPY: Copy one model's data into a new model memory slot.

RESET: Reset the model memory to the factory defaults

DELETE: Delete a model memory

RENAME: Rename the model to a name of your choice

MDL TYPE: Model Type menu

ACRO: Provides programming for most powered fixed-wing aircraft

GLID: Provides programming for gliders, both powered and unpowered

HELI: Provides helicopter programming functions

CHANNEL: Model channel assignment menu. Allows control of any channel to be assigned to a switch or joystick axis.

TRIM STEP: Trim step size adjustment menu (1-200). Default value is 12

TRAINER: Trainer options menu

SENSOR: Telemetry sensor setup menu

SPECTRA: Receiver set-up

Receiver: Receiver type selection menu, Optima/Minima, Maxima or SLT

Range Check: Power down mode for performing preflight range check

Binding: Use to bind a new receiver to your Flash 8

Scanning: Scan the frequency table for the clearest channels

MODE: Stick mode change Mode 1-4

MANAGEMENT: System management menu

BACKLIGHT: Adjusts how long the backlight remains active

CONTRAST: Adjusts the screen contrast

BATTERY: Used to specify the battery type used in the transmitter: NiMh/NiCD, LiPo or LiFe

UI FEEDBACK: Turns the user interface sound feedback on or off

WARNING SETUP: Controls the various transmitter warnings

RF CHECK: Prompts if you are "Ready to Transmit"

HIGH THROTTLE: Warns if the throttle is not in "idle" position

FLIGHT CONDITION: Warns if a flight condition switch is on

FEEDBACK: Used to select types of user feedback (off, tone, vibration)

INFO.: Displays transmitter information such as software version

Model Select Menu

Create a new model: When you create a new model you are also prompted to do other setup items. To avoid repetitive information it is recommended that you read the quick start guides in order to understand what other steps are required when creating a new model. The "New" option is only available if the last model in the list is selected.

Select an existing model:

a. In the model select screen, use the jog dial to scroll through the list of models. When you have highlighted the model you want to work with, press the jog dial to confirm your selection.

b. Highlight "SELECT" and press the jog dial.

c. When asked if you would like to change the model, highlight "YES" and press the jog dial.

Copy one model's data into another memory slot:

a. If you haven't already done so, create a new model by following the ACRO or HELI Quick Start instructions.

b. In the model select menu, highlight the model you wish to copy data from and press the jog dial.

c. Scroll to "COPY" and press the jog dial to enter the copy menu.

d. Press the jog dial to activate the destination menu.

e. Scroll to select the model memory slot where you would like to place the data. Press the jog dial to confirm your selection.

f. When prompted to confirm that you want to copy, select "YES" and press the jog dial to confirm your selection.

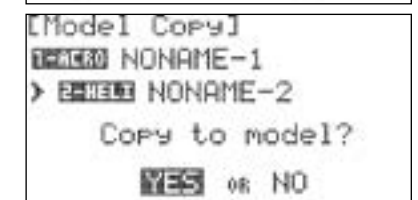
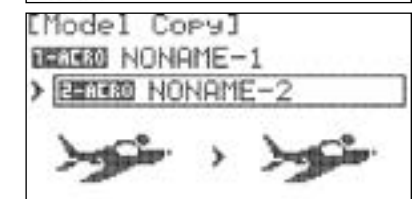
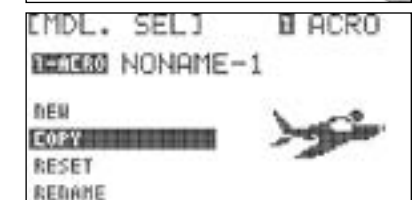
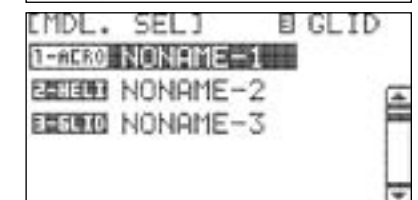
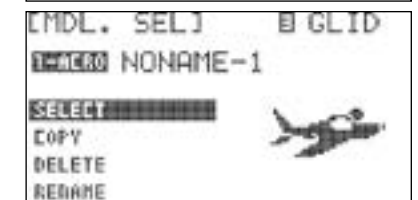
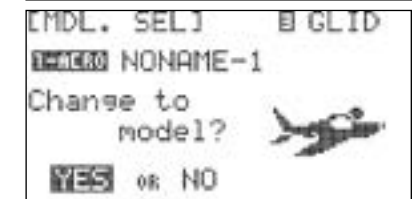
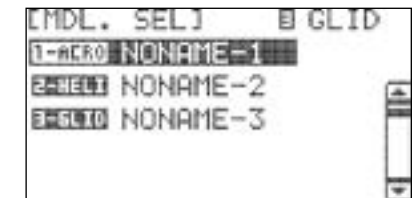

Model Select Menu cont.

Reset the active model memory slot to factory default settings:

a. In the model select menu, highlight the model you wish to reset and press the jog dial. You can only reset the active model.

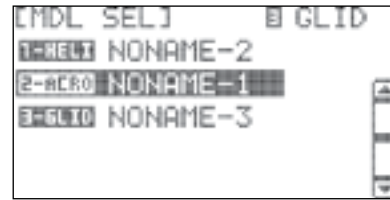

b. Scroll to "RESET" and press the jog dial.

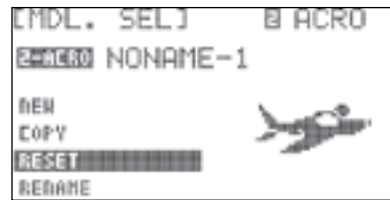

c. When prompted to confirm that you want to reset the model, select "YES" and press the jog dial to confirm your entry. You have now cleared all of the programming for the model. The only settings that will remain are the model name, receiver type and wing and tail types.

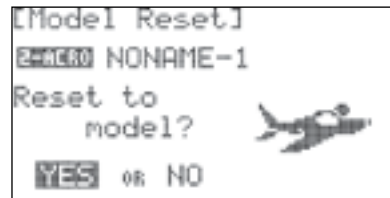

You can only reset an active model.

Delete a model memory:

a. In the model select menu, highlight the model you wish to delete and press the jog dial. You cannot delete the active model.

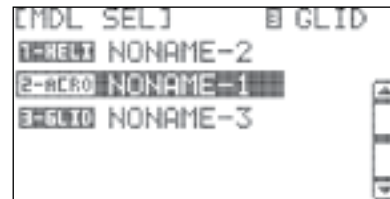

b. Scroll to "DELETE" and press the jog dial.

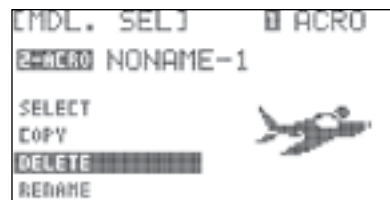

c. When prompted to confirm that you want to delete the model, select "YES" and press the jog dial to confirm your entry.

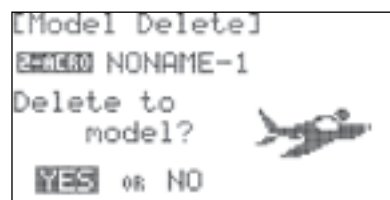

Model Select Menu cont.

Rename a model:

a. In the model select menu, highlight the model you wish to rename. Press the jog dial to confirm your selection.

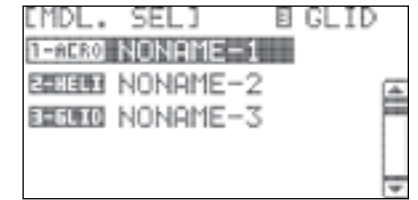

b. Scroll to "RENAME" and press the jog dial to enter the naming screen.



c. In the field displaying the current model name, scroll to the character you want to change and press the jog dial to activate it. The cursor will blink under the active character.



d. Use the jog dial to scroll through the characters and press it once to select the character.

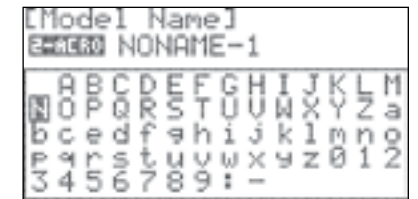



e. Repeat steps c and d until you have renamed the model.

f. Press the back button to return to the model select menu.

Model Type Menu

The Model Type screen defines the features of the active model. These are the features specified during the "create a new model" process, in addition to all of the default features. Here we can define all the choices you have while setting up your aircraft in the Flash 8.

There are three types of aircraft "Model Type" menus:

-  ACRO: For powered fixed-wing aircraft and most multi-rotors.
-  GLID: For powered and unpowered gliders.
-  HELI: All helicopters will use the HELI menu.

Model Type ACRO Menu Programming

1. From the System Menu select MDL TYPE.



2. Press the jog dial once to enter the Model Type Selection Menu. ACRO is the first and default selection.

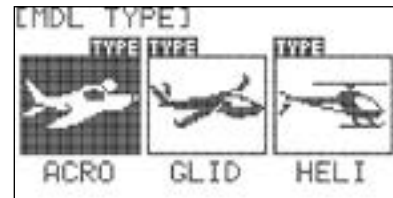

3. Press the jog dial again to enter the ACRO setup menu.

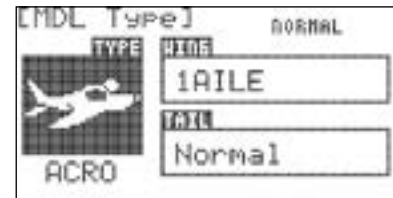

4. In the ACRO setup menu, you will set your wing and tail choices. Scroll to "WING" and press the jog dial to activate the menu.

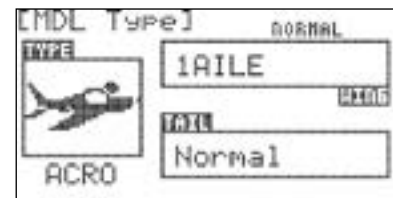

The choices for Normal wing types are:

- 1AILE: Single aileron servo
- 1AILE+1FLAP: Single aileron servo and single flap servo
- 1AILE+2FLAP: Single aileron servo channel and two flap servos
- 2AILE: Two aileron servos
- 2AILE+1FLAP: Two aileron servos and one flap servo
- 2AIL+2FLAP: Two aileron servos and two flap servos

Additionally there are setups for Delta (Elevon) wing type models:

- 2AILE: Two elevon servos
- 2AILE+1FLAP: Two elevon servos and one flap servo
- 2AILE+2FLAP: Two elevon servos and two flap servos

5. Once you have selected your wing type, press the jog dial to confirm your selection.

Model Type ACRO Menu Programming cont.

6. Scroll to "TAIL" and press the jog dial to activate the menu. The choices for tail type are dependent on the type of wing you selected.

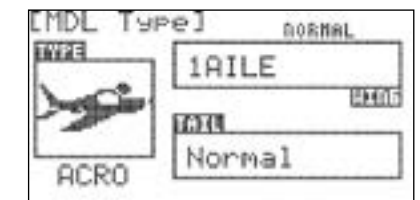

The tail types you may choose with the Normal wing types are:

NORMAL:

Rudder is located on a vertical stabilizer and elevator is on a horizontal stabilizer.

V-TAIL:

Two control surfaces in a V-configuration operate together providing both yaw (rudder) and pitch (elevator) control.

Ailevator:

Each half of the elevator is controlled by a dedicated servo to provide pitch (elevator), and roll (aileron) control.

The tail types you may choose with Delta wing types are:

None: For flying wing models without a rudder.

1Servo: For flying wing models with a single rudder servo.

2Servo: For flying wing models with dual rudder servos.

7. Select the tail type for your model and press the jog dial to confirm your selection.

8. Use the back button to return to the System Menu.

Model Type GLID Menu Programming

1. From the System Menu select "MDL TYPE".



2. Press the jog dial once to enter the model type selection menu. Scroll to model type "GLID".

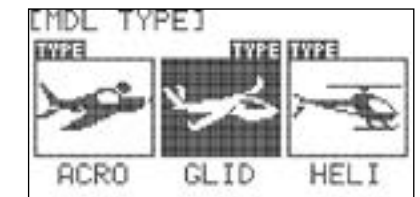

3. Press the jog dial again to enter the ACRO setup menu.

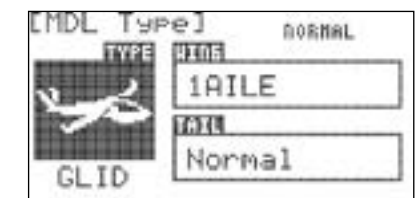

Model Type GLID Menu Programming cont.

4. In the GLID setup menu, you will set your wing and tail choices. Scroll to "WING" and press the jog dial to activate the menu.

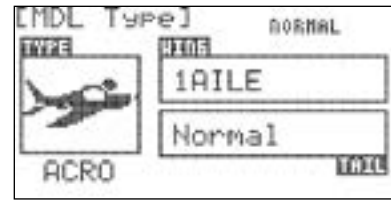

The choices for Normal GLID wing type are:

- 1AILE: Single aileron servo
- 1AILE+1FLAP: Single aileron servo and single flap servo
- 1AILE+2FLAP: Single aileron servo and two flap servos
- 2AILE: Two aileron servos
- 2AILE+1FLAP: Two aileron servos and one flap servo
- 2AIL+2FLAP: Two aileron servos and two flap servos

Additionally there are setups for Delta (Elevon) wing type models:

- 2AILE: Two elevon servos
- 2AILE+1FLAP: Two elevon servos and one flap servo
- 2AILE+2FLAP: Two elevon servos and two flap servos

5. Once you have selected your wing type, press the jog dial to confirm your selection.

6. Scroll to "TAIL" and press the jog dial to activate the menu.

The choices for tail type are dependent on the type of wing you selected.

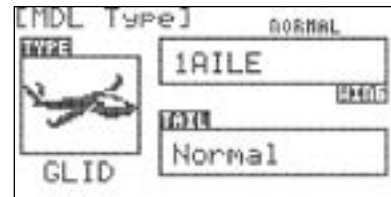

7. Select the tail type for your model and press the jog dial to confirm your selection.

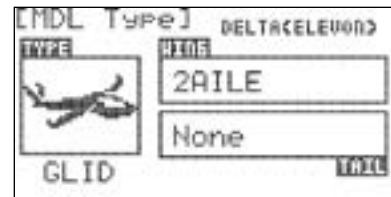

8. Use the back button to return to the System Menu.

The tail types you may choose with the Normal wing types are:

NORMAL:

Rudder is located on a vertical stabilizer and elevator is on a horizontal stabilizer.

V-TAIL:

Two control surfaces in a V-configuration operate together providing both yaw (rudder) and pitch (elevator) control.

Ailevator:

Each half of the elevator is controlled by a dedicated servo to provide pitch (elevator), and roll (aileron) control.

The tail types you may choose with delta wing types are:

None: For flying wing models without a rudder.

1Servo: For flying wing models with a single rudder servo.

2Servo: For flying wing models with dual rudder servos.

Model Type HELI Menu Programming

1. From the System Menu select MDL TYPE.



2. Press the jog dial once to enter the Model Type Selection Menu.

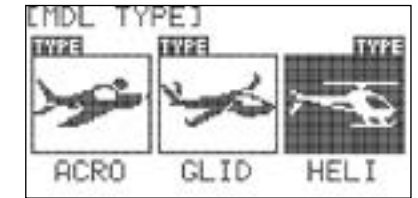

3. Scroll to highlight "HELI" and press the jog dial to enter the HELI setup menu.

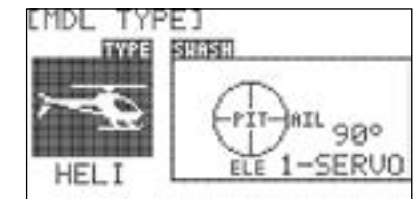

4. In the HELI menu you will set the swash type. Scroll to highlight "SWASH" and press the jog dial to activate the menu.

There are six types of Swash types to choose from:

- 90° 1 servo: The three swash servos are configured 90° apart, and each servo provides independent control of collective, pitch, or roll.
- 120° 3 servos: The three swash servos are configured 120° apart, and all servos operate in unison to control collective, pitch, and roll.
- 140° 3 servos: The three swash servos are configured 140°/140°/80° apart, and all servos operate in unison to control collective, pitch, and roll.
- 180° 2 Servo: In case of when the swash is formed in 90° angle and two servos control the mixing of aileron and pitch.
- 90° 3 Servo: In case of when the swash is formed in 90° angle and three servos control the mixing of aileron, elevator, and pitch.
- 90° 4 Servo: In case of when the swash is formed in 90° angle and four servos control the mixing of aileron, elevator, and pitch.

Your helicopter's manual will indicate the type of swashplate on your model.

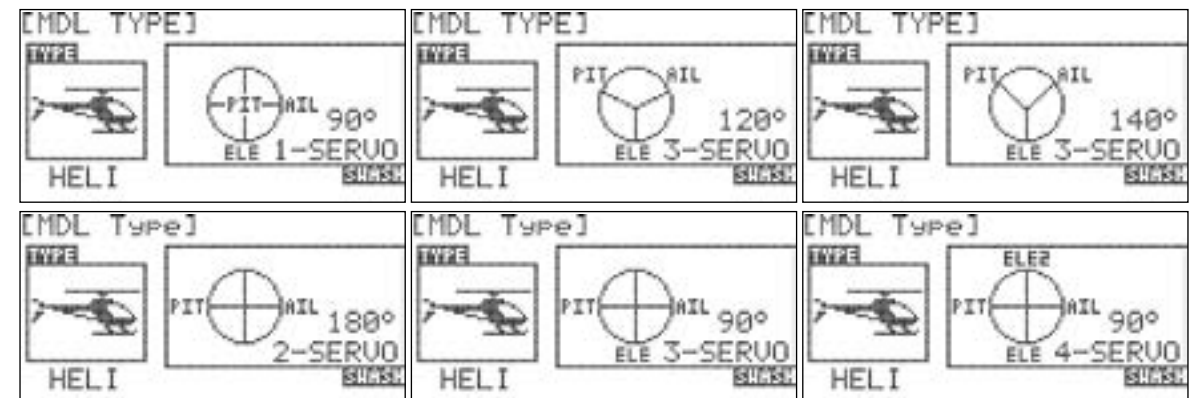

5. Select the swash type for your helicopter and press the jog dial to confirm your selection.

6. Press the back button to return to the System Menu.

Channel Selection Menu

The Channel menu allows you to choose the function (AILE, THRO, RUDD, etc.) and control input method (joystick, switch, slider, etc) for each channel. This programming function permits a high level of creativity in the way you can customize the Flash 8 to suit your personal flying style.

1. From the System Menu scroll to "CHANNEL" and press the jog dial to enter the channel selection menu.



 **Note** Default channel assignments are based on the model type, wing, tail and swash type setups. However, you can assign any channel to any function or transmitter control.

2. To assign a channel to a specific function, scroll to highlight the channel you want to assign and press the jog dial to enter the menu.

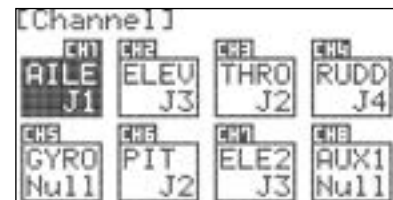

3. Scroll to the channel function field (AILE, ELEV, etc.) and press the jog dial to activate the selection menu.



4. Scroll through the choices to select the desired function of that channel and press the jog dial to confirm your selection.

5. To assign a channel to a specific transmitter control, scroll to the input device field (J1, LS, etc.) and press the jog dial to activate the selection menu.

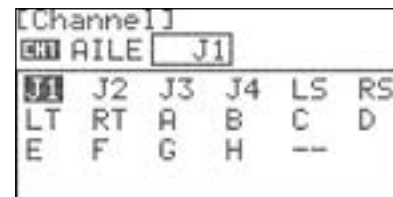

6. Scroll through the choices to select the desired transmitter control you want to use for that channel and press the jog dial to confirm your selection.

7. Use the back button to return to the System Menu.

Trim Step

The Trim Step screen is utilized to change the amount of movement seen on the servos with each adjustment, or "beep" of the gimbal trim levers. Larger values equate to greater servo movement with each trim adjustment.

1. From the System Menu, highlight "TRIM STEP" and press the jog dial to enter the trim step menu.



2. Scroll to the trim you wish to adjust and push the jog dial to activate the adjustment menu.

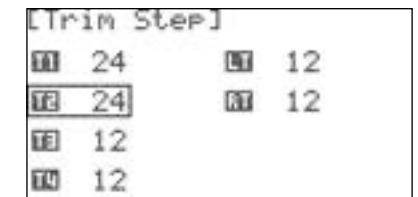

3. Scroll to change the trim step value and press the jog dial to confirm your entry. Trim step adjustment values range from 1~200.

4. Press the back button to return to the system menu.

Trainer

The Flash 8 can be paired with another Hitec transmitter to create a master/slave setup that is useful when instructing student pilots.

Utilizing the various trainer functions of the Flash 8, you can:

- A. Select which controls (RUDD, THRO, AIL, ect.) the student will command.
- B. Use the mix feature to give the student a percentage of the control throw while the master has the remainder.

In addition to training, you can also use the Flash 8's pass-through function to control head tracking devices for First Person View flying.



Note The Flash 8 is compatible with all other Hitec transmitter products using the 3.2mm stereo plug.



Warning When using the Flash 8 in trainer mode, the following items must be verified before flying:

- A. The master radio must be programmed with the model to be flown.
- B. The slave or student transmitter must have the proper servo reverse and trim settings to match the master transmitter.

Trainer cont.

Within the trainer menu, you can set the Flash 8 as a "Master radio", set the trainer switch and activate the other features. To do this, the transmitter must be in transmit mode. If not in transmit mode, the only options you will have are the "pupil" options.

To configure the trainer function:

1. From the System Menu, scroll to highlight "TRAINER" and press the jog dial once to enter the activation menu.



2. Press the jog dial again to activate the menu.

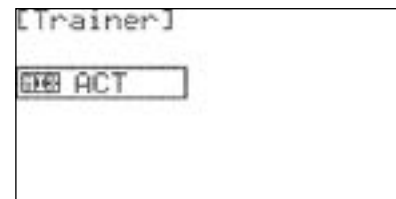

3. Rotate the jog dial to select "ACT" (activate), then press the jog dial to confirm your selection and activate the trainer menu.

4. Scroll to highlight "MODE" and press the jog dial to activate the menu.

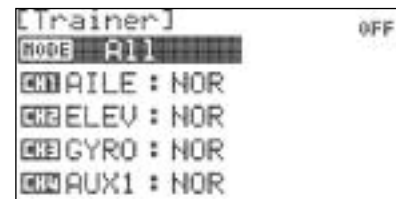

5. Scroll to select the number of channels the student radio can control:

ALL: Gives the student access to all control channels 1~8.
 STICK: Gives the student access only to the stick (gimbal) channels 1~4. Press the jog dial to confirm your selection.

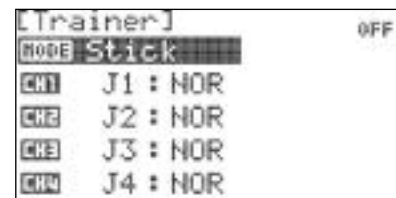

6. Within the trainer menu, you can choose to limit the control the student has for each channel by selecting one of the three choices:

- NOR for full control
- MIX for limited control
- OFF for no control

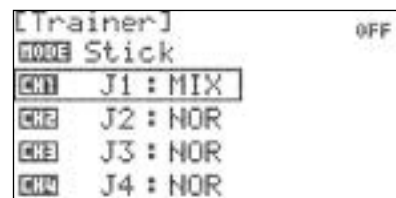

7. To adjust the level of control for any channel, scroll to the channel you want to change and press the jog dial to activate the selections.

8. Scroll to select "NOR", "MIX", or "OFF" and press the jog dial to confirm your selection.

Trainer cont.

9. To select a switch that will be used for the trainer function, scroll down to the S/W field and press the jog dial to enter the switch selection menu, press the jog dial again to activate the switch selections.

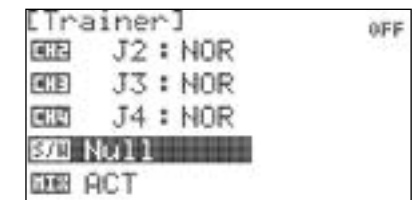

10. Scroll to select a switch to activate the trainer function. Press the jog dial to confirm your selection.
 a. If you choose the "NULL" option, the mix will remain inactive at all times for this model.

b. If you choose a switch:

- The switch position menu will appear. Scroll to highlight the switch position that you will use to enable the mix. Press the jog dial to confirm your selection.

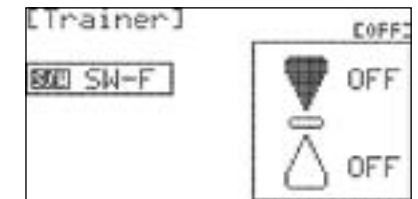

- Scroll to select "ON" and press the jog dial to confirm your selection. If you toggle the selected switch, the field in the top right corner of the screen will indicate when the mix is active.

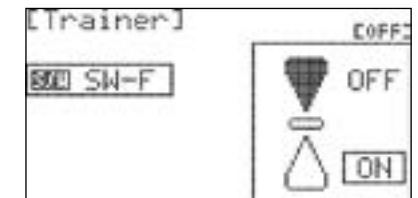

11. Press the back button twice to return to the System Menu.

To disable the trainer function:

1. Scroll to highlight the "MIX" field in the trainer menu and press the jog dial to activate the menu.
2. Select "INH" (inhibit) and press the jog dial to confirm your selection.
3. Press the back button to return to the model function menu.

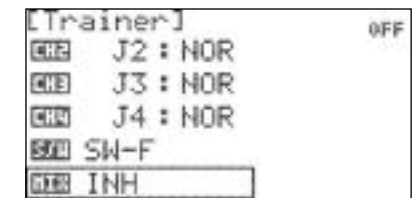

Sensor

When used with the Optima series of telemetry-capable receivers, the Flash 8 has the ability to communicate a variety of information from the airplane directly to the transmitter.

Refer to Section Seven: Using the Telemetry System on page 111 for more information about utilizing the telemetry features of the Flash 8.

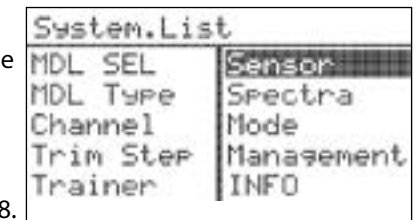

Spectra

The spectra menu is utilized to manage the interface between the Flash 8 transmitter and the receiver for each aircraft. This includes specifying the receiver type, performing a range check, binding the receiver, and specifying a frequency scan. All of these functions are covered in the receiver selection section on page 15.

Control Modes

The Flash 8 is capable of operating in control Modes 1 - 4. The default is "Mode 2" for radios sold in North America, as this is generally preferred by the majority of pilots.

1. From the System Menu, scroll to highlight "MODE" and press the jog dial to enter the mode selection menu.

2. Press the jog dial again to activate the mode selections.

3. Scroll through the modes until you find the one you would like to use. The selected mode will be applied to each new model that is created. Press the jog dial to confirm your selection.

4. Press the Back button to exit the Mode Select menu.

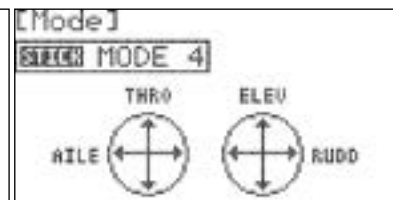
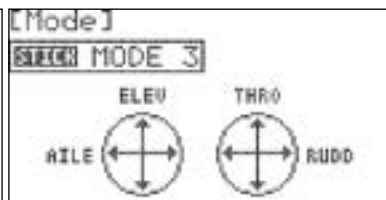
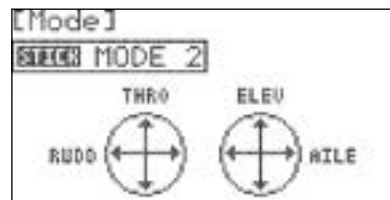
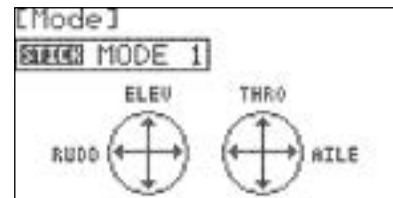
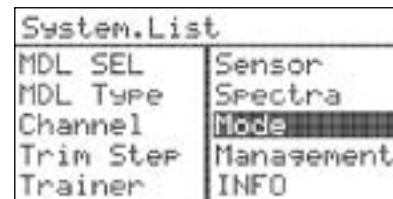

Note

Some modes require additional adjustments to the hardware of the Flash 8 transmitter. For more information on the Flash 8's hardware adjustments refer to Appendix A. Hardware Adjustments.

Management Menu

The Management menu allows you to tailor numerous system-wide features of the Flash 8.

From the management menu, you can control the following:

User Interface screen backlight duration and contrast.

Battery type used in the transmitter.

UI Feedback - Audible tones during warnings and when you press or scroll the jog dial.

Warning Setup – Audible warnings when the transmitter is powered on.

1. From the System Menu, scroll to "MANAGEMENT" and press the jog dial to enter the management menu.



2. Scroll to highlight "BACKLIGHT" and press the jog dial to activate the menu.

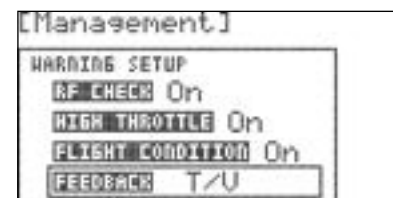

3. Scroll to select the amount of time that the screen backlight will stay active without manipulating the jog dial or back button. Press the jog dial to confirm your selection.

Management Menu cont.

4. Scroll to highlight "CONTRAST" and press the jog dial to activate the menu.

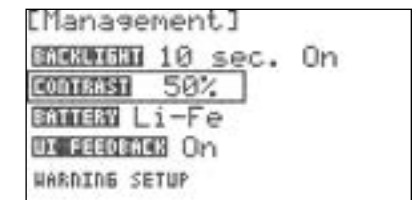

5. Scroll to adjust the contrast level of the display screen. Press the jog dial to confirm your selection.

6. Scroll to highlight "BATTERY" and press the jog dial to activate the menu.

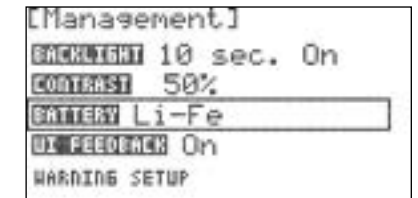

7. Scroll to select the battery type used in the transmitter. Press the jog dial to confirm your selection.

8. Scroll to highlight "UI FEEDBACK" and press the jog dial to activate the menu.

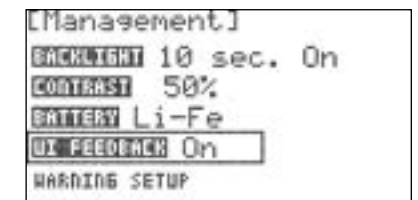

9. Scroll to select "ON" or "OFF". When user interface feedback is turned on, the radio emits a beep each time the jog dial is scrolled or pressed. The transmitter will emit continuous beeps if a warning is active. Press the jog dial to confirm your selection.

10. Scroll to highlight "WARNING SETUP" and press the jog dial to activate the menu.

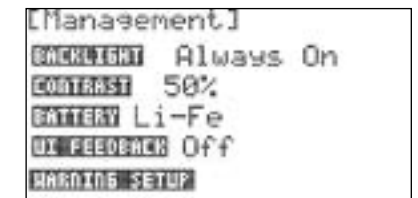

11. Scroll to highlight "RF CHECK" and press the jog dial to activate the menu.

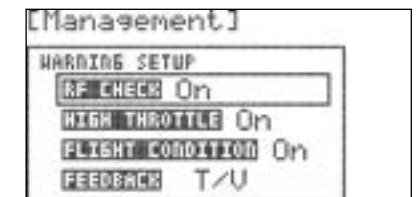

12. Scroll to select "ON" or "OFF". When RF check is turned on, the radio will prompt you to approve signal transmission each time the unit is powered on. Otherwise, the radio will automatically begin transmitting when powered on. Press the jog dial to confirm your selection.

13. Scroll to highlight "HIGH THROTTLE" and press the jog dial to activate the menu.

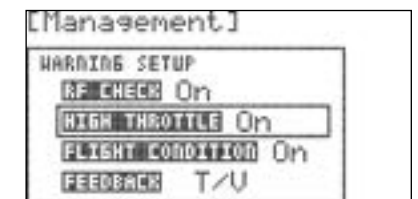

14. Scroll to select "ON" or "OFF". When high throttle is turned on, the radio will warn you if the throttle stick is not at idle when the unit is powered on. Press the jog dial to confirm your selection.

Management Menu cont.

15. Scroll to highlight "FLIGHT CONDITION" and press the jog dial to activate the menu.

16. Scroll to select "ON" or "OFF". When the flight condition warning is turned on, the radio will warn you if any programmed flight conditions are active when the unit is powered on. Press the jog dial to confirm your selection.

17. Scroll to highlight "FEEDBACK" and press the jog dial to activate the menu.

18. Scroll to select "OFF", "VIBRO", "TONE", or "T/V". The three types of cues when a warning condition is met are a flashing light on the front of the transmitter, vibration, and beeping. When feedback is turned off, the flashing light will be the only indicator. When set to "VIBRO", the light and vibration will be active. When set to "TONE" the light and beeping will be active. When set to "T/V", all three indicators will be active during a warning condition. Press the jog dial to confirm your selection.

INFO

The Info screen displays the current firmware information for the radio.

1. From the system menu, highlight "INFO" and press the jog dial once to see the information.
2. Press the back button to return to the system menu.

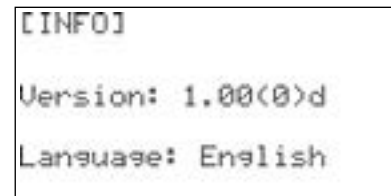
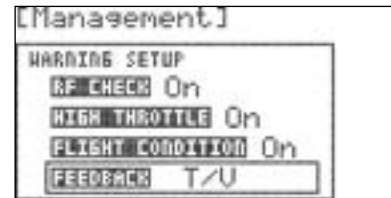
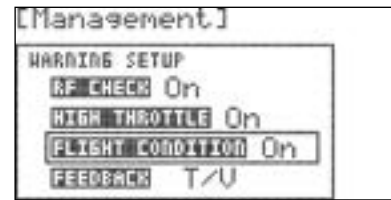

Common Model Programming Menu

The Model Function menu contains options that relate to all model types (common) as well as options which are specific to fixed wing models (ACRO/GLID) or helicopters (HELI). This section illustrates the common model function options. The features specific to fixed wing or helicopter model types are covered in Section Five and Section Six respectively.



If you have not already programmed a model with the preceding quick start guide, we encourage you to do so before tackling the model programming section of the manual.

From the Model Function menu, you can program the following common functions:

REVERSE: Specify the direction that a servo will travel with a given control input.

SUB TRIM: Fine-tune the neutral point of a servo.

D/R & EXP: Specify Dual-Rate and Exponential settings for control surface servos.

EPA: Specify the servo travel limits for channels 1-8.

S.Speed: Specify the transit speed for servos on channels 1-8.

PROG.MIX: Configure up to five user-programmable mixes.

TIMER: Configure two user-programmable timers.

MONITOR: Observe graphic feedback to control inputs.

THRO Lock: Assign a switch to lock and release throttle movements.

Working with the Common Model Function Menus

1. Turn on the transmitter. When prompted with the "Ready to transmit?" message, highlight "NO" and press the jog dial.

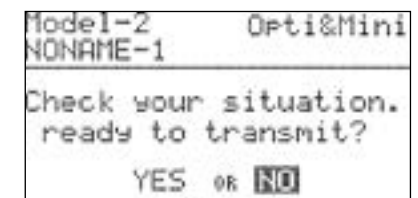

2. To access the model function menu, press and hold the jog dial.

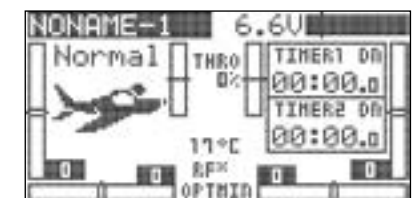

3. The menu options shown reflect the parameters defined for the active model in the model type menu (Model Type, Wing, Tail, Swash). Common model items are integrated with the fixed-wing and helicopter-specific options in the menu.



Servo Reverse

The Reverse screen allows you to specify the direction of servo rotation for channels 1-8 of the active model.

1. From the model menu, scroll to highlight "REVERSE" and press the jog dial once to enter the reverse menu.



2. Scroll to the channel to be reversed and press the jog dial to activate the selections:



NOR (default): Normal rotation.

REV: Reverse rotation.

3. Once you have chosen the desired direction, press the jog dial to confirm your selection.



4. Press the back button to return to the model menu.

Sub Trim

The Sub Trim menu is used to make very fine adjustments to the center point, or "neutral point" of a servo. It is typically preferable to have the servo arm 90° to the pushrod at the neutral point. Use sub trim settings to attain this orientation. Then, adjust the length of the pushrod to achieve the desired neutral control surface position.

1. From the model menu, scroll to highlight "SUB TRIM" and press the jog dial once to enter the sub trim menu.



2. Scroll to the channel to be adjusted and press the jog dial to activate the menu.

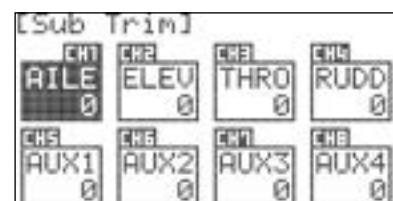

3. Rotate the jog dial clockwise or counter-clockwise to alter the servo neutral point.

4. Once you have achieved the desired neutral point, press the jog dial to confirm your change.

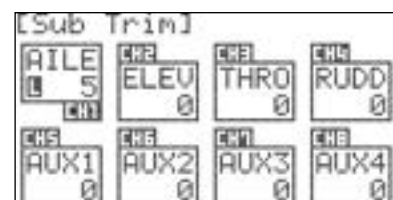

5. Press the back button to return to the model menu.

Dual Rates

The Dual Rate (D/R) feature provides a method to define two different values of servo movement ("rates") on the same channel. You may want low control rates during takeoff and landing and higher rates when performing aerobatics. One or more switches are assigned to allow the pilot to select high or low rates.

Exponential Rate ("EXP") is a powerful function that is often used to make a twitchy model easier to control. Negative exponential values typically make a model less sensitive to moderate control inputs, yet you still have the same amount of overall control throw. Positive exponential values are generally detrimental to a model's controllability and should be avoided.



Tip Before entering the D/R & EXP menu, it is helpful to decide which switch or switches you want to control dual rates, as well as the switch positions that will be used for high-rates and low-rates. The same switch can be used to manage dual rates for one or more control functions.

1. From the model menu, scroll to highlight "D/R & EXP" and press the jog dial once to enter the D/R & EXP menu.



2. Scroll to highlight the function field (RUDD, ELEV, etc) and press the jog dial to activate the menu.



3. Rotate the jog dial to select the desired function and press the jog dial to confirm your selection.

4. Locate the switch that you will use to control dual rates for this function and move it to the desired position for high-rates.



5. Scroll to highlight the "D/R" field and press the jog dial to activate the D/R sub-menu.

6. By scrolling, you can highlight either the "L/U" (left/up), the "R/D" (right/down) field, or both fields. If you want the dual rates to be the same for both directions of servo travel (most common) highlight both fields and press the jog dial.



7. Rotate the jog dial to increase (clockwise) or decrease (counter-clockwise) the desired travel for the servo(s) in high-rate mode. The value is a percentage of the available servo throw from neutral to full left (AILE, RUDD) or full up (ELEV). Press the jog dial to confirm your input.

8. Press the back button the return to the D/R & EXP menu.

Exponential

9. Scroll to highlight the "EXP" field and press the jog dial to activate the menu.

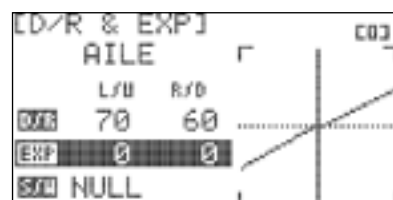

10. By scrolling, you can highlight either the "L/U" (left/up), the "R/D" (right/down) field, or both fields. If you want the exponential movement to be the same for both directions of servo travel (most common) highlight both fields and press the jog dial.

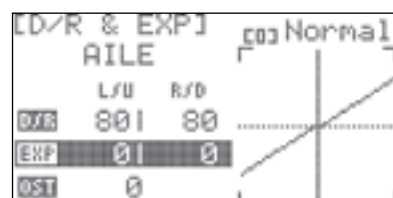

11. Rotate the jog dial to increase (clockwise) or decrease (counter-clockwise) the desired exponential value in high-rate mode. This value is applicable for control inputs from neutral to full left (AILE, RUDD) or full up (ELEV). Press the jog dial to confirm your input.

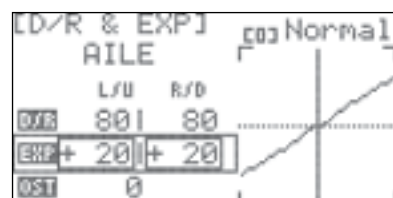

12. Press the back button to return to the D/R & EXP menu.

Tip The on-screen graph provides real-time feedback regarding how your D/R & EXP inputs affect servo movement. Note that the y-axis of the graph moves as you manipulate the relevant control stick for the current function being edited.

13. Offset: Scroll to highlight the "OST" (Offset) field and press the jog dial to activate the menu.

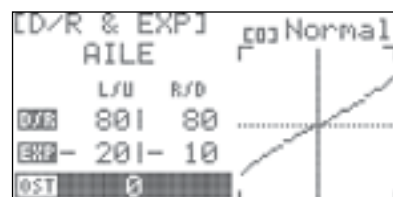

14. Offset allows you to set the neutral point of the servo to different than the midpoint of its travel. This is helpful when you require more servo travel in one direction than the other. Scroll to select the desired amount of offset and press the jog dial to enter your selection.

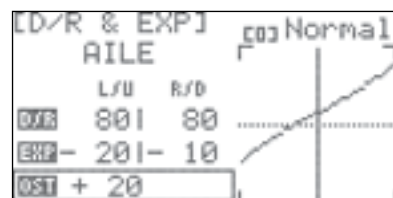

15. Switch Assignment: Scroll down to highlight the S/W field and press the jog dial to activate the menu.

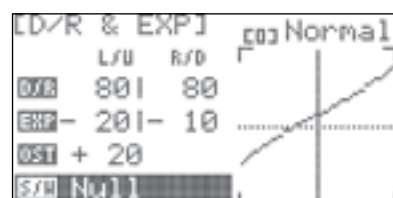

Exponential cont.

16. Scroll to select the switch you have chosen to control dual rates for this function and press the jog dial to confirm your selection. If you choose one of the 3-position switches, you can set triple rates (high/mid/low).

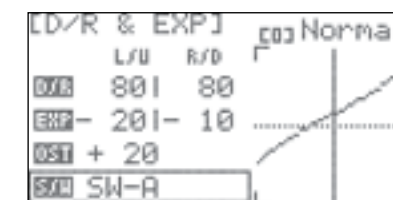

17. Physically move the switch to the desired position for low-rates or mid rates and repeat steps 5-16 to input the desired throws and exponential values for the selected function.

18. Repeat steps 4-17 for each control function.

Note If you are using multiple flight modes, you must define D/R and EXP values for each flight mode. The top field of the D/R & EXP menu allows you to select the desired flight mode. Alternately, you may select the desired flight mode using the assigned F.Cond switch.

Tip The final settings in the D/R & EXP menu should reflect the model aircraft manufacturer's suggested control surface deflections for each function. Some manufacturers also provide suggested exponential values.

19. Press the back button to return to the model menu.

End Point Adjustment

The End Point Adjustment (EPA) feature allows you to fine tune the maximum servo movement for every channel. This capability is very useful when dealing with models that require small control movements or in cases where binding/damage could occur from excessive control movement.

1. From the model menu, scroll to highlight "EPA" and press the jog dial once to enter the EPA menu.

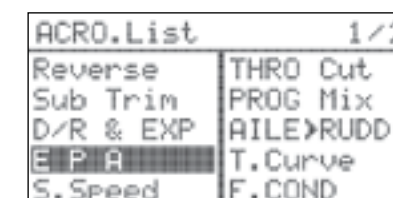

2. Scroll to the channel to be adjusted and press the jog dial to activate the EPA sub-menu.

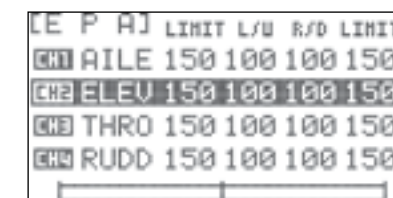

3. Scroll to highlight the left "LIMIT" field and press the jog dial to activate the menu. This field defines the maximum servo travel that can be set in the "left/up" direction. The value shown is a percentage of standard servo travel (the default limit is 150%).

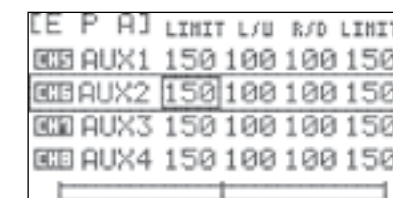

4. Rotate the jog dial to increase (clockwise) or decrease (counter-clockwise) the desired "left/up" servo limit. Press the jog dial to confirm your input.

End Point Adjustments cont.

5. Scroll to highlight the "L/U" (left/up) field and press the jog dial to activate the menu.

6. Rotate the jog dial to increase (clockwise) or decrease (counter-clockwise) the desired left (AILE, RUDD) or up (ELEV) servo endpoint. Press the jog dial to confirm your input.

7. Scroll to highlight the "R/D" (right/down) field and press the jog dial to activate the menu.

8. Rotate the jog dial to increase (clockwise) or decrease (counter-clockwise) the desired right (AILE, RUDD) or down (ELEV) servo endpoint. Press the jog dial to confirm your input.

9. Scroll to highlight the right "LIMIT" field and press the jog dial to activate the menu. This field defines the maximum servo travel that can be set in the "right/down" direction. The value shown is a percentage of standard servo travel (the default limit is 150%).

10. Rotate the jog dial to increase (clockwise) or decrease (counter-clockwise) the desired "left/up" servo limit. Press the jog dial to confirm your input.

11. Press the back button the return to the EPA menu.

12. Repeat steps 2-11 for each channel you would like to adjust.

13. Press the back button to return to the model menu.

Servo Speed

The Servo Speed (S.SPEED) feature allows you to fine tune the maximum servo movement for every channel. This capability is very useful when dealing with models that require small control movements or in cases where binding/damage could occur from excessive control movement.

1. From the model menu, scroll to highlight "S.SPEED" and press the jog dial once to enter the servo speed menu.

2. Scroll to the channel to be adjusted and press the jog dial to activate the menu.

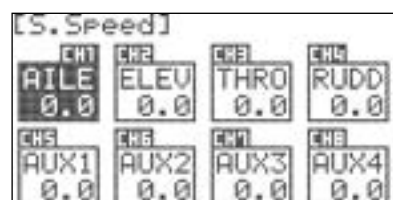
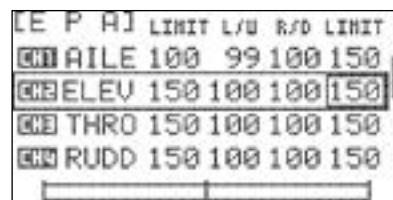
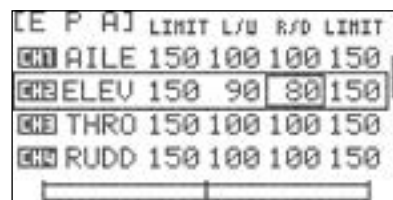
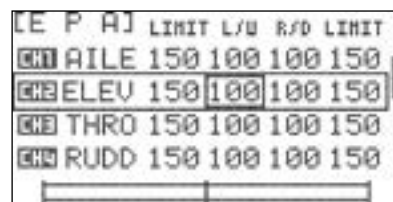

Servo Speed cont.

3. Rotate the jog dial clockwise or counter-clockwise to alter the speed of the servo. The selected value is the transit time of the servo in seconds (0-25.0).

4. Once you have achieved the desired servo speed, press the jog dial to confirm your change.

5. Press the back button to return to the model menu.

Programmable Mixes

The Flash 8 provides five user-programmable mixes which can be used for a wide variety of custom functions that are not available with the built-in mixes and options. A common use for these mixes is to correct unwanted behavior of an aircraft. This could be automatically applying a bit of rudder with throttle to counteract torque/P-factor effects, or applying elevator during knife-edge flight to correct an undesired tucking tendency. Maybe you just want the head on your model's pilot figure to turn when you taxi out to the runway. Programmable mixes can make it happen.

1. From the model menu, scroll to highlight "PROG.MIX" and press the jog dial once to enter the programmable mix menu.

2. Scroll to highlight the mix to be configured and press the jog dial to activate the selection.

3. Rotate the jog dial to select ACT (activate), then press the jog dial to confirm your selection and activate the sub-menu for the selected mix.

4. Scroll to select the master/slave field and press the jog dial to activate the menu. Now scroll to select the master function field (left field) and press the jog dial to activate the menu.

5. Scroll to select the desired function to be the master function for the mix (THRO, RUDD, GEAR. etc.) and press the jog dial to confirm your selection. Now scroll to select the slave function field (right field) and press the jog dial to activate the menu.

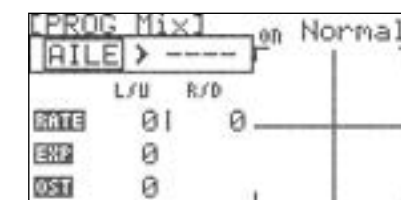
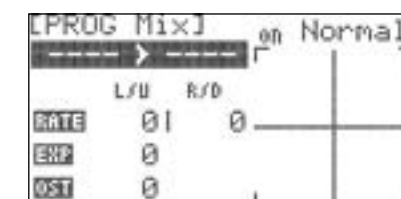
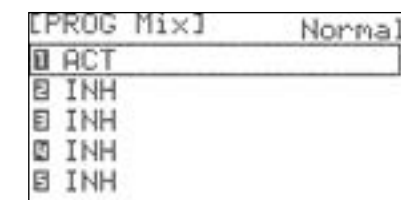
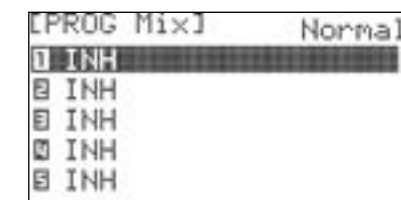
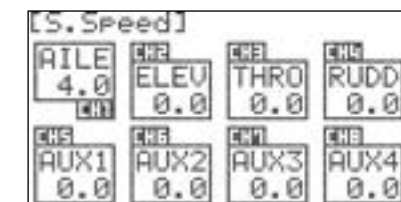

Programmable Mixes cont.

6. Scroll to select the desired function to be the slave function for the mix and press the jog dial to confirm your selection. Press the back button to return to the programmable mix sub-menu.

7. Scroll to highlight the "RATE" field and press the jog dial to activate the menu.

8. Rotate the jog dial to highlight the "L/U" (left/up), the "R/D" (right/down) field, or both fields. If you want the mix affect the movements of the slave servo equally in both directions, highlight both fields and press the jog dial. Otherwise you can adjust the values individually.

9. Rotate the jog dial to increase (clockwise) or decrease (counter-clockwise) the desired left, right(AILE,RUDD) or up, down(ELEV) servo movement for the slave function. Press jog dial to confirm your input.

10. Rotate the jog dial to increase (clockwise) or decrease (counter-clockwise) the desired right (AILE, RUDD) or down (ELEV) servo movement for the slave function. Press the jog dial to confirm your input. Press the Back button to return to the programmable mix sub-menu.

11. Scroll to highlight the "EXP" (exponential) field and press the jog dial to activate the menu.

12. Rotate the jog dial to increase or decrease the desired amount of exponential throw on the slave servo when operating with the mix. Press the jog dial to confirm your input.

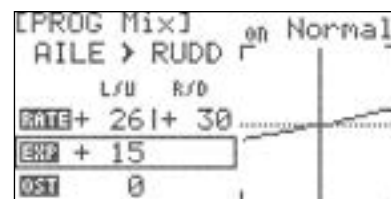
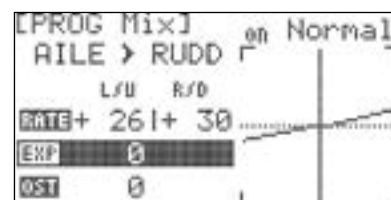
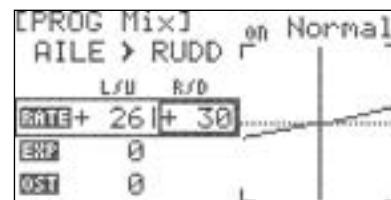
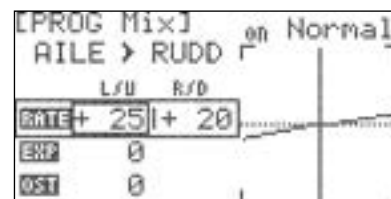
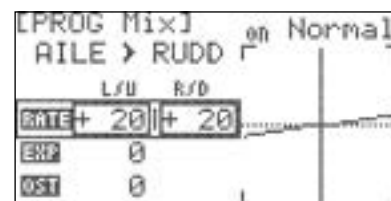
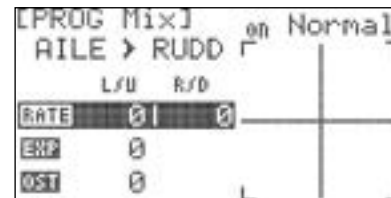
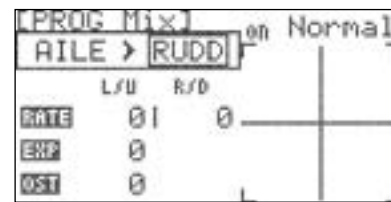

Tip See the "D/R & EXP" menu on pages 47-49 for more information about exponential rates.

Programmable Mixes cont.

13. Scroll to highlight the "OST" (offset) field and press the jog dial to activate the menu.

14. Rotate the jog dial to increase or decrease the desired amount of offset between the master and slave channels when operating with the mix. Press the jog dial to confirm your input.

15. The "I/O" (input/output) field is for display only. It shows the value of the master and slave channels as you actuate the relevant controls. These values are reflected in the graph as well.

16. Scroll to highlight the "SPEED" field and press the jog dial to activate the menu.

17. Rotate the jog dial to increase or decrease the transit time of the slave servo (in seconds) when operating with the mix. Press the jog dial to confirm your input.

18. Scroll to highlight the "TRIM" field and press the jog dial to activate the menu. With this feature enabled, the slave feature will respond to trim changes as well as control inputs for the master feature. When disabled, the slave feature ignores trim changes and reacts only with control inputs to the master feature.

19. Rotate the jog dial to select "OFF" or "ON" and press the jog dial to confirm your input.

20. Scroll to highlight "S/W" (switch) and press the jog dial to activate the menu.

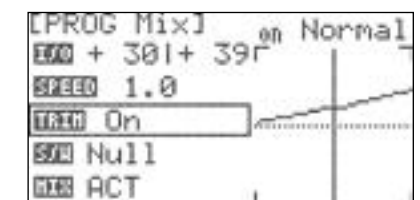
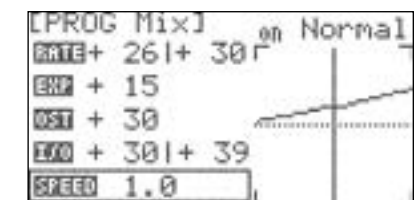
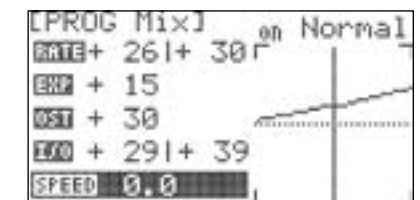
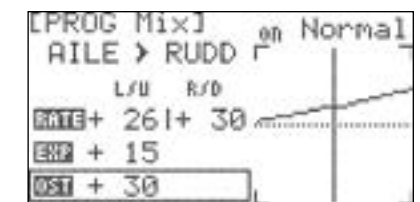
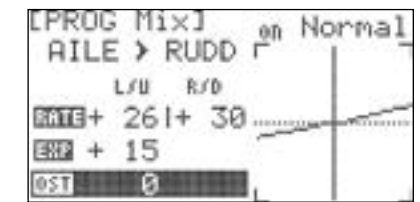

Programmable Mixes cont.

21. Press the jog dial again to enable selections in the S/W menu.

22. Scroll to select the switch that you will use to activate the mix and press the jog dial to confirm your selection. If "NULL" is selected, the mix will always be active.

23. If you selected a switch, the switch position menu will appear. Scroll to highlight the switch position(s) that you will use to enable the mix. Press the jog dial to confirm your selection.

24. Scroll to select "ON" and press the jog dial to confirm your selection. If you toggle the selected switch, the field in the top right corner of the screen will indicate if the mix is on or off.

25. Press the back button to return to the programmable mix sub-menu.

26. Set up programmable mix in accordance with a Flight Condition:

- The upper right field of the menu displays which Flight Condition is currently active and will be programmed.
- Scroll to the Flight Condition field and press the jog dial to activate the menu.
- Choose the desired flight condition and press the jog dial to confirm your selection
- Repeat steps 9-24 to define the settings for each flight condition.

27. Press the back button to return to the model function menu.

28. To inhibit this mix, scroll to the "MIX" field and press the jog dial to activate the menu.

29. Scroll to select "INH" and press the jog dial to confirm your selection.

30. Press the back button twice to return to the model function menu.

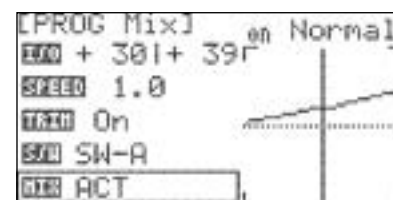
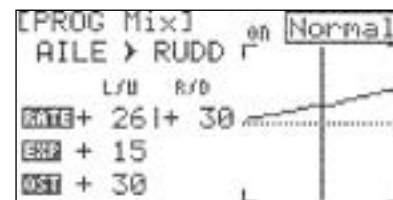
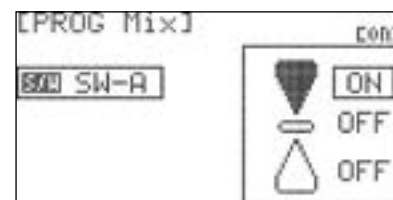
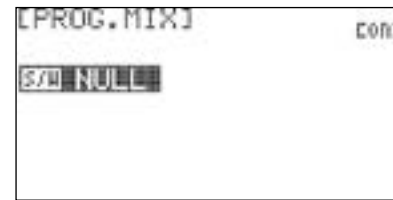

Timers

The Flash 8 features two customizable timers that can be triggered by switches or the throttle position. Downward counting timers can be helpful in making sure that you land before running out of fuel or battery power. You could also use an upward counting timer to measure the duration of your glider flights. Both timers are displayed on the home screen.

To configure a timer:

1. From the model menu, scroll to highlight "TIMER" and press the jog dial once to enter the timer menu.

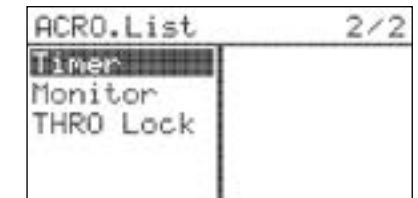

You can also enter the timer menu directly from the home screen. Scroll to highlight a timer on the screen and press the jog dial.

2. Scroll to highlight "INH" under TIMER-1 and press the jog dial to activate the menu.

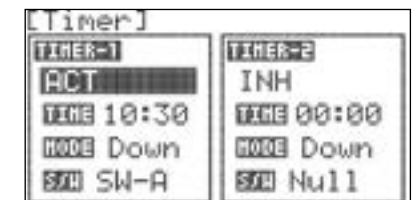

3. Scroll to select "ACT" (active) and press the jog dial to confirm your selection.

4. Scroll to highlight "TIME" and press the jog dial to activate the menu.

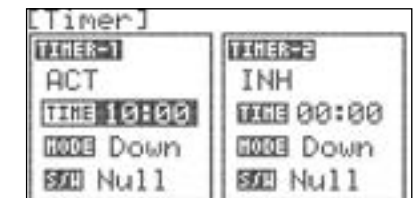

5. Press the jog dial again to activate the minute field.

6. Scroll to select the desired start value for minutes on Timer-1 and press the jog dial to confirm your selection.

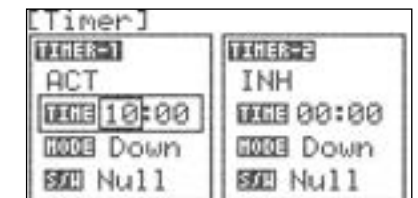

7. Scroll to highlight the seconds field and press the jog dial to activate the menu.

8. Scroll to select the desired start value for seconds on start Timer-1 and press the jog dial to confirm your selection.

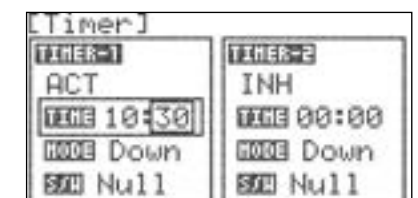

9. Press the Back button to return to the timer menu.

Timers cont.

10. Scroll to highlight "MODE" and press the jog dial to activate the menu.

11. Scroll to select "UP" or "Down" and press the jog dial to confirm your selection.

12. Scroll to highlight "S/W" and press the jog dial to activate the menu.

13. Press the jog dial again to activate the switch selection sub-menu.

14. Scroll to select the desired activation switch for the timer. Press the jog dial to confirm your selection.

a. Selecting "NULL" will cause the timer to be inactive.

b. If you selected a switch, the switch position menu will appear.

- Scroll to highlight the switch position(s) that you will use to activate the timer.

- Press the jog dial to confirm your selection.

- Scroll to select "ON" and press the jog dial to confirm your selection. If you toggle the selected switch, the field in the top right corner of the screen will indicate if the mix is on or off.

- Press the back button to return to the programmable mix sub-menu.

c. If you selected "THR", the throttle position menu will appear.

- Scroll to highlight the top "OFF" field and press the jog dial to confirm your selection.

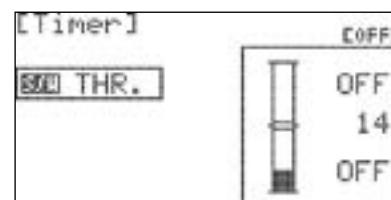
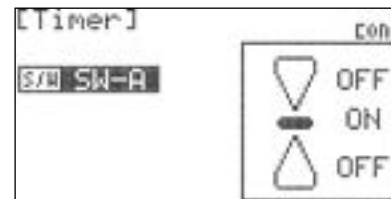
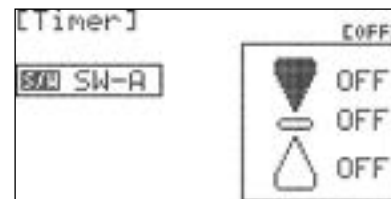
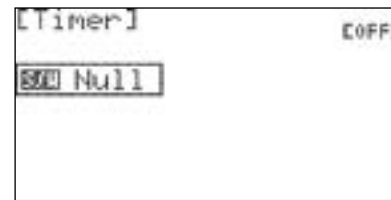
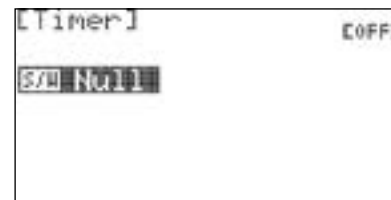
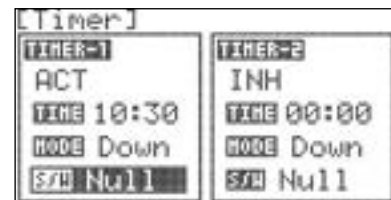
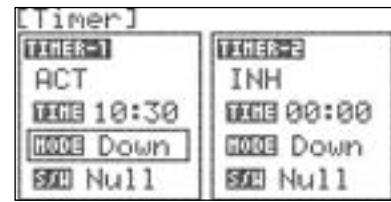

Timers cont.

- Scroll to select "ON" and press the jog dial to confirm your selection.

- Scroll to highlight the middle field and press the jog dial to activate the menu.

- Move the throttle stick to the position where you want the timer to turn on. We suggest a position just above idle. Note the double line on the screen moves in conjunction with the throttle stick position.

- Scroll to raise the bar on the screen to the double line. Press the jog dial to confirm your selection. The timer will run when the throttle is at or above this setting. It will pause when the throttle is below this setting. If you cycle the throttle position, the field in the top right corner of the screen will indicate when the timer turns on and off.

- Press the back button to return to the timer sub-menu.

To reset a timer:

1. From the home screen, scroll to highlight a timer and press the jog dial once to enter the timer menu.

2. Scroll to highlight "TIME" and press the jog dial to activate the menu.

3. Press the back button twice to return to the home screen.

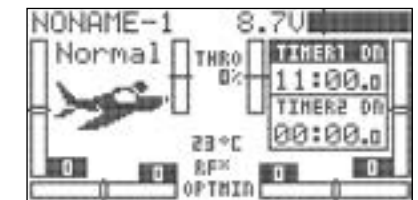
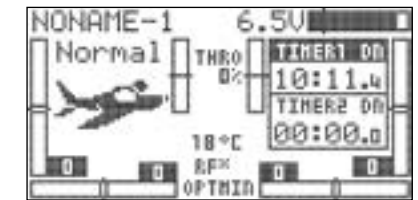
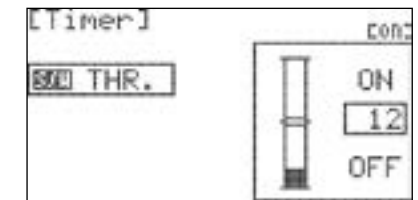
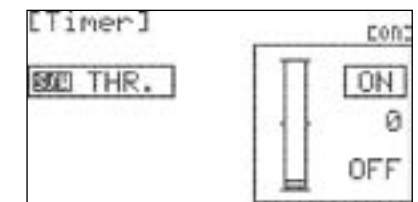

Servo Monitors

The Monitor function will display a graphic representation of all eight channels as they are manipulated with the Flash 8's controls. There are also channel cycling and neutralization functions.

1. From the model menu, scroll to highlight "MONITOR" and press the jog dial once to enter the monitor menu.

2. Manipulate the control inputs (including dual-rate switches) and observe the bar graphs indicate the movement for each channel. This screen is useful to verify that each channel is configured with the intended end points and dual rates.

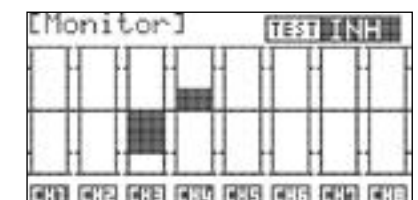
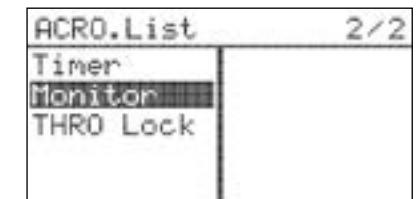

Servo Monitors cont.



Warning

If you are configuring an electric-powered model, remove the propeller(s) or secure the aircraft before performing the next steps. The test functions will cause an active Electronic Speed Control to drive the motor(s) at varying power levels, including full throttle. An unsecured model can cause substantial bodily injury and/or property damage. Also be mindful of models with retractable landing gear or similar functions that require special attention.

3. Press the jog dial to activate the test menu.

4. Scroll to highlight "Move" and press the jog dial to confirm your selection.

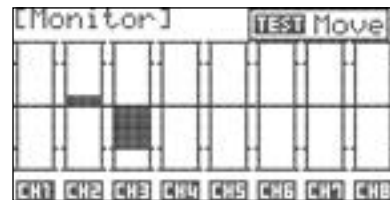

5. Observe as the transmitter cycles the designated range of travel for every channel that has been assigned a control input.

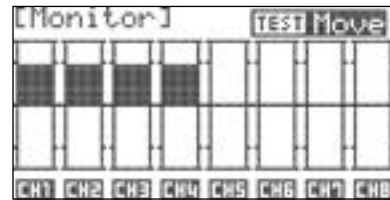

6. The cycle test can be halted by either selecting another option in the test menu or pressing the back button to return to the model function menu.

7. Scroll to highlight "Neu" (neutral) and press the jog dial to confirm your selection.

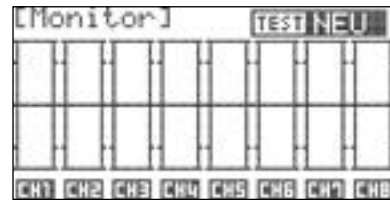

8. Observe that all channels with assigned control inputs have been set to their neutral position (including all trim or sub-trim settings). This screen is useful to position the servos when setting pushrod lengths for control surfaces.

9. The neutral setting can be halted by either selecting another option in the test menu or pressing the back button to return to the model function menu.

THRO Lock

The Flash 8 features a "throttle lock" function that can be activated when the transmitter is transmitting a signal. We encourage you to use the throttle lock feature as a safety precaution against "accidental throttle application".

1. To turn the throttle lock on, highlight "THRO Lock" from the model setup menu and press the jog dial to enter the setup screen.

2. To select which switch will be used for the throttle lock press the jog dial to enter the switch selection menu.

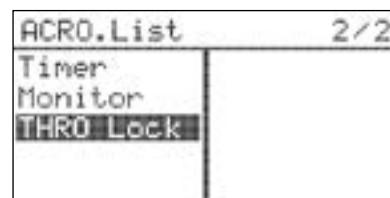

THRO Lock cont.

3. Scroll to select a switch used to activate the throttle lock function. Press the jog dial to confirm your selection.

a. If you choose the "NULL" option, the function will remain inactive at all times for this model.

b. If you choose a switch:

- The switch position menu will appear. Scroll to highlight the switch position that you will use to enable the function. Press the jog dial to confirm your selection.

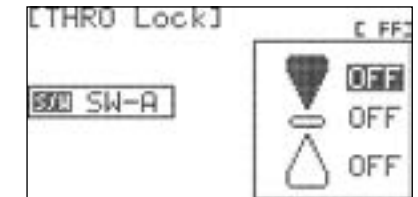

- Scroll to select "ON" and press the jog dial to confirm your selection. If you toggle the selected switch, the field in the top right corner of the screen will indicate when the mix is active.

4. Press the back button twice to return to the Model menu.

Acro and Glider Programming Menu

When the active model is configured as fixed-wing (ACRO or GLID) model type, the Model Function menu contains programming options which are useful for fixed-wing aircraft. This section describes the features and programming steps for the ACRO and GLID model function menus.



If you have not already programmed a model with the preceding quick start guide, we encourage you to do so before tackling the model programming section of the manual.

From the Model Function menu, you can program the following fixed-wing-specific functions:

- FLT.COND:** Configure specific control settings for different phases of flight.
- AIL DIFF:** Configure aileron servos to move further upwards than down.
- ELEVON MIX:** Specify independent pitch and roll control throws for aircraft with elevons.
- V-TAIL MIX:** Specify independent pitch and yaw control throws for aircraft with a V-tail.
- AILEVATOR:** Specify independent pitch and roll control throws for aircraft with ailevators (also called "tailerons").
- AIL>RUD:** User-adjustable mix that defines rudder movement with aileron control inputs.
- ELEV>CAMB:** Alter wing control surfaces with elevator inputs.
- Camber Mix (GLID only):** Adjust wing control surfaces with switch movements.
- FLAP CON:** Mix elevator throw with flap movement.
- Landing (ACRO only):** Fine tune aileron, elevator and flaps for landing mode.
- B-fly (GLID only):** Configure wing control surfaces to act as an air brake (also known as "crow").
- GYRO:** Specify gyro on/off and sensitivity settings.
- THRO CUT (ACRO only):** Configure a kill switch for glow/gas motors.
- T.CURVE (ACRO only):** Specify non-linear throttle response.

Working with the Acro/Glid Model Function Menu

1. Turn on transmitter. When prompted to transmit, select "NO".
2. Verify that the active model is an ACRO or GLID model type.
3. To access the model function menu, press and hold the jog dial.

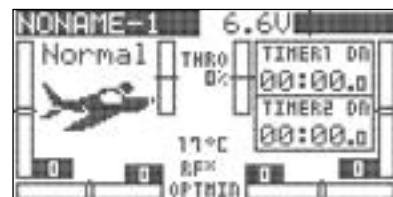

Working with the Acro/Glid Model Function Menu



ACRO Model Function Menu Page 1



ACRO Model Function Menu Page 2



Glider Model Function Menu Page 1

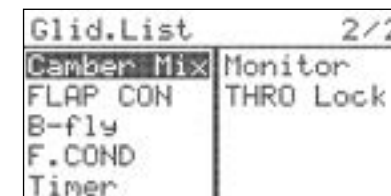

Glider Model Function Menu Page 2

4. The menu options shown reflect the parameters defined for the active model in the model type menu (Model Type, Wing and Tail). ACRO and GLID-specific items are integrated in the menu with the options that are common to all model types.

Flight Conditions

The Flash 8 allows you to program up to five flight conditions. This powerful feature lets you define customized trim values and mix settings for different phases of flight.

The flight conditions for fixed wing aircraft are:

- ACRO**
- 1. Normal
- 2. COND-2
- 3. COND-3
- 4. COND-4

If you are using multiple flight conditions and any of the listed features, you must define set-up values for each flight mode. Typically, the top field of each affected menu allows you to select the desired flight mode. Alternately, you may select the desired flight mode using the assigned F.Cond switch.

The following features support flight condition programming in ACRO or GLID mode:

- | | |
|---------------------------|------------------------|
| Dual Rate and Exponential | Throttle Curve |
| Aileron Differential | Flap Control |
| Programmable Mixes | Landing |
| Aileron > Rudder Mix | Camber Mix (GLID only) |
| Elevator > Camber Mix | Butterfly (GLID only) |
| Elevon | Gyro |

Flight Conditions cont.

1. From the model menu, rotate the jog dial to highlight "F.COND" and press the jog dial once to enter the flight conditions menu.



2. Scroll to the flight condition to be configured and press the jog dial to confirm your selection.

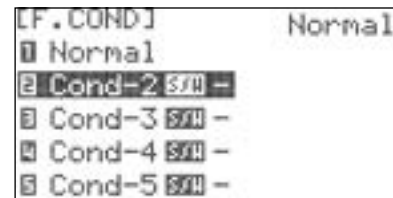

3 Press the jog dial again to activate the switch selection menu (not applicable in "Normal" flight condition).

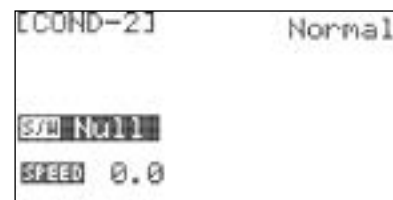

4. Scroll to select the switch that you will use to activate this flight condition and press the jog dial to confirm your selection.

a. If "NULL" is selected, the flight condition will be inactive.

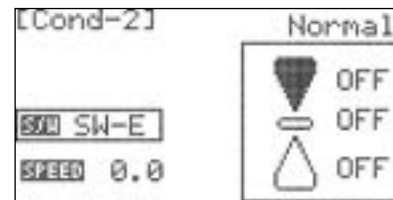

b. If you selected a switch, the switch position menu will appear.
- Scroll to highlight the switch position that you will use to enable the flight condition. Press the jog dial to confirm your selection.

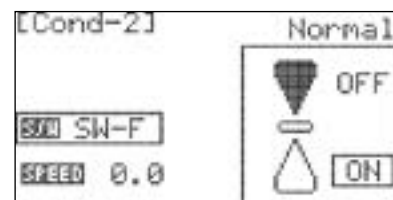

- Scroll to select "ON" and press the jog dial to confirm your selection. If you toggle the selected switch, the field in the top right corner of the screen will indicate which flight condition is active.



Tip

If more than one flight condition is concurrently enabled, the condition with the highest number (per the table shown above) will be active. The field just below the model icon on the Home screen indicates the active flight condition.

- Press the back button twice to return to the flight conditions menu.

Flight Conditions cont.

5. Scroll to highlight the "SPEED" field and press the jog dial to activate the menu.

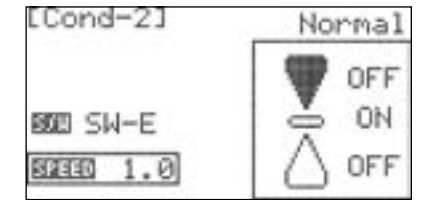

6. Scroll to define the amount of time (0.0 to 10.0 seconds) to transition the settings when this flight condition is enabled. Press the jog dial to confirm your selection. This feature can be utilized to prevent sudden control surface movements when switching between flight conditions.

7. Press the back button to return to the flight conditions menu and repeat steps 2-6 to define further flight conditions.

8. Press the back button twice to return to the model function menu.

Aileron Differentials

The Aileron Differential function allows you to program greater upward aileron movement than downward movement on models with more than one wing servo. This setup is commonly used to correct airplanes that tend to yaw in the opposite direction of a roll (adverse yaw). You may also wish to configure aileron-rudder mixing in this situation.

1. From the model menu, rotate the jog dial to highlight "AIL DIFF" and press the jog dial once to enter the aileron differential menu.

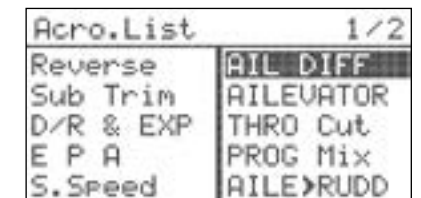

2. Scroll to the "RATE" field and press the jog dial to activate the menu.

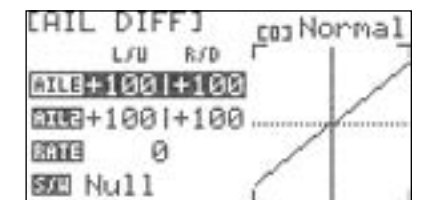

3. Rotate the jog dial to input the desired rate value. This value represents the difference between 100% downward travel and the adjusted travel. A rate value of 50 is typically a good starting point. Note that the travel values displayed in the "AILE" and "AIL2" fields reflect changes to the rate value.

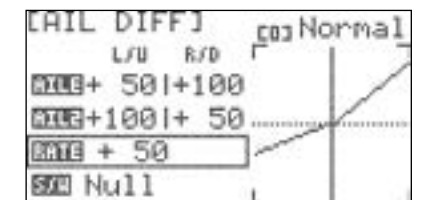

Aileron Differentials cont.

4. Scroll to the "S/W" field and press the jog dial to activate the menu.

5. Rotate the jog dial to select a switch to control aileron differential settings. Press the jog dial to confirm your selection. If you choose the "NULL" option, the current settings will remain active at all times for this model. If you choose a switch, repeat steps 2-4 to define the settings for each switch position.

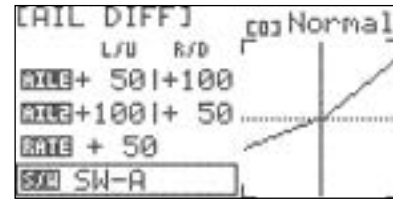

You can customize individual travel values in the "AILE" and "AIL2" fields by scrolling to those fields and activating the sub-menus.

6. Press the back button to return to the model function menu.



If you are using multiple flight conditions, you must define aileron differential values for each flight condition. The top field of the AIL DIFF menu allows you to select the desired flight condition. Alternately, you may select the desired flight condition using the assigned F.Cond switch.

Elevon Mixing

Flying wing aircraft are most often set up using elevon control surfaces. The Flash 8 mixes the aileron and elevator functions to provide this configuration with just one flight control surface per wing panel.



It is not necessary to access or change this menu to fly an elevon-equipped aircraft. The default values are 100% in all directions.

1. From the model menu, rotate the jog dial to highlight "Elevon Mix" and press the jog dial once to enter the elevon mix menu.



2. Scroll to the top "AILE" field and press the jog dial to activate the menu.

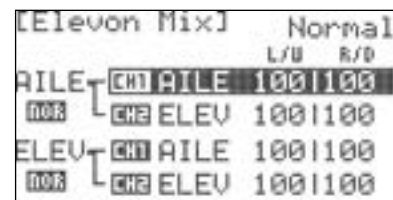

Elevon Mixing cont.

3. Scroll to highlight the "L/U" (left/up) field and press the jog dial to activate the menu.

4. Rotate the jog dial to increase (clockwise) or decrease (counter-clockwise) the desired endpoint for the servo attached to the "AILE" receiver slot. This value regards the servo travel when a left roll command is given. Press the jog dial to confirm your input.

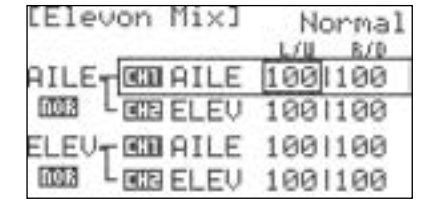

5. Scroll to highlight the "R/D" (right/down) field and press the jog dial to activate the menu.

6. Rotate the jog dial to increase (clockwise) or decrease (counter-clockwise) the desired servo endpoint when a right roll command is given. Press the jog dial to confirm your input.

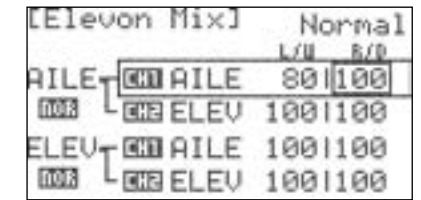

7. Press the back button to return to the elevon mix menu.

8. Scroll to the top "ELEV" field and press the jog dial to activate the menu.

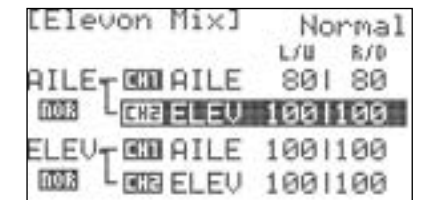

9. Scroll to highlight the "L/U" (left/up) field and press the jog dial to activate the menu.

10. Rotate the jog dial to increase (clockwise) or decrease (counter-clockwise) the desired endpoint for the servo attached to the "ELEV" receiver slot. This value regards the servo travel when a left roll command is given. Press the jog dial to confirm your input.

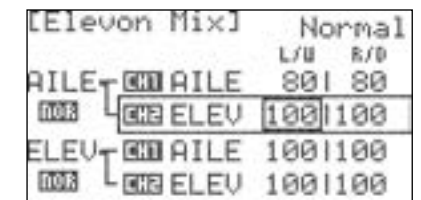

11. Scroll to highlight the "R/D" (right/down) field and press the jog dial to activate the menu.

12. Rotate the jog dial to increase (clockwise) or decrease (counter-clockwise) the desired servo endpoint when a right roll command is given. Press the jog dial to confirm your input.

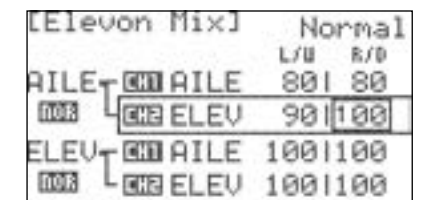

13. Press the back button to return to the elevon mix menu.

14. Repeat steps 2-13 using the lower "AILE" and "ELEV" fields to set the servo endpoints when pitch (elevator) commands are given.

Elevon Mixing cont.

15. If aileron or elevator functions operate in the incorrect direction, highlight the direction field ("nor") under the function name and press the jog dial to activate the menu.

16. Scroll to select "rev" and press the jog dial to confirm your selection. Verify that the control surfaces now move in the correct direction.

17. Push the Back button twice to return to the model function menu.

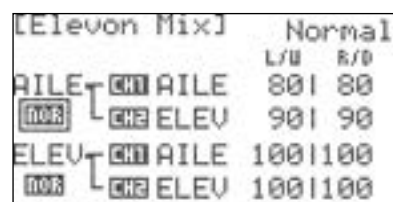

Note

If you are using multiple flight conditions, you must define elevon values for each flight condition. The top field of the Elevon Mix menu allows you to select the desired flight condition. Alternately, you may select the desired flight condition using the assigned F.Cond switch.

V-Tail Mixing

Aircraft with a V-tail configuration can use this function to specify the limits of travel for both tail control surface servos.

1. From the model menu, rotate the jog dial to highlight "V.Tail Mix" and press the jog dial once to enter the V-tail mix menu.

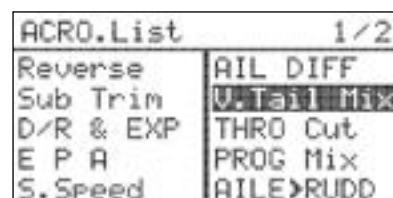

2. Scroll to the top "ELEV" field and press the jog dial to activate the menu.

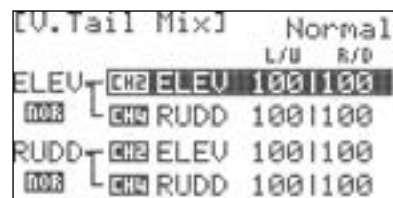

3. Scroll to highlight the "L/U" (left/up) field and press the jog dial to activate the menu.

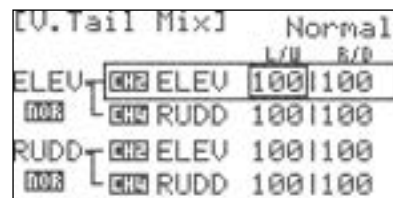

4. Rotate the jog dial to increase (clockwise) or decrease (counter-clockwise) the desired endpoint for the servo attached to the "ELEV" receiver slot. This value regards the servo travel when a pitch up command is given. Press the jog dial to confirm your input.

V-Tail Mixing cont.

5. Scroll to highlight the "R/D" (right/down) field and press the jog dial to activate the menu.

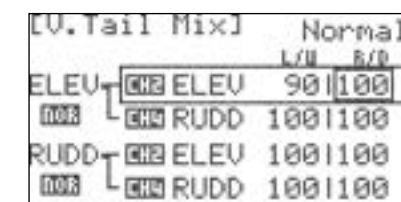

6. Rotate the jog dial to increase (clockwise) or decrease (counter-clockwise) the desired servo endpoint when a pitch down command is given. Press the jog dial to confirm your input.

7. Press the back button to return to the V-tail menu.

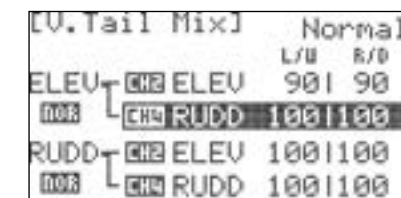

8. Scroll to the top "RUDD" field and press the jog dial to activate the menu.

9. Scroll to highlight the "L/U" (left/up) field and press the jog dial to activate the menu.

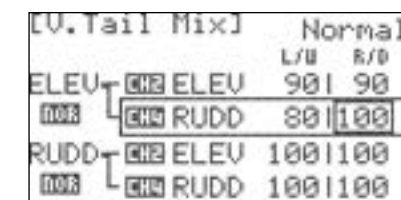

10. Rotate the jog dial to increase (clockwise) or decrease (counter-clockwise) the desired endpoint for the servo attached to the "RUDD" receiver slot. This value regards the servo travel when a pitch up command is given. Press the jog dial to confirm your input.

11. Scroll to highlight the "R/D" (right/down) field and press the jog dial to activate the menu.

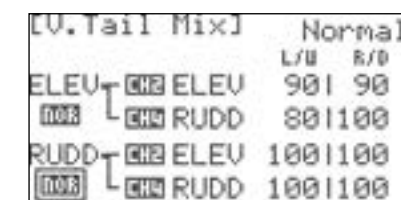

12. Rotate the jog dial to increase (clockwise) or decrease (counter-clockwise) the desired servo endpoint when a pitch down command is given. Press the jog dial to confirm your input.

13. Press the back button to return to the V-tail Mix menu.

14. Repeat steps 2-13 using the lower "ELEV" and "RUDD" fields to set servo endpoints when yaw (rudder) commands are given.

15. If elevator and/or rudder functions operate in the incorrect direction, highlight the direction field ("nor") under the reversed function and press the jog dial to activate the menu.

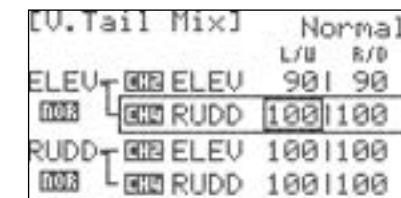

V-Tail Mixing cont.

16. Scroll to select "rev" and press the jog dial to confirm your selection. Verify that the control surfaces now move in the correct direction.

17. Push the back button twice to return to the model function menu.



Note

If you are using multiple flight conditions, you must define elevon values for each flight condition. The top field of the Elevon Mix menu allows you to select the desired flight condition. Alternately, you may select the desired flight condition using the assigned F.Cond switch.

Ailevator Mixing

The Ailevator feature allows the configuration of a two-servo or "split" elevator setup. It also features an "aileron to split elevator" mix which allows the elevators to provide roll control. This feature, also called "tailerons", is commonly used on jet models.

1. From the model menu, rotate the jog dial to highlight "Ailevator" and press the jog dial once to enter the V-tail mix menu.



2. Scroll to the top "ELEV" field and press the jog dial to activate the menu.

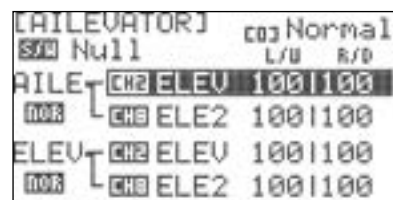

3. Scroll to highlight the "L/U" (left/up) field and press the jog dial to activate the menu.

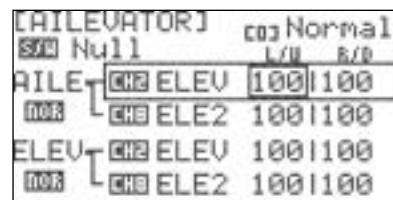

4. Rotate the jog dial to increase (clockwise) or decrease (counter-clockwise) the desired endpoint for the servo attached to the "ELEV" receiver slot. This value regards the servo travel when a pitch up command is given. Press the jog dial to confirm your input.

5. Scroll to highlight the "R/D" (right/down) field and press the jog dial to activate the menu.

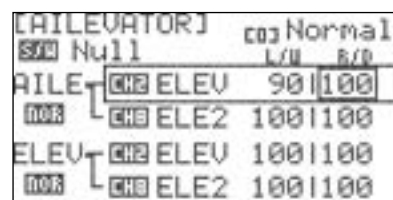

6. Rotate the jog dial to increase (clockwise) or decrease (counter-clockwise) the desired servo endpoint when a pitch down command is given. Press the jog dial to confirm your input.

Ailevator Mixing cont.

7. Press the back button to return to the ailevator menu.

8. Scroll to the top "ELE2" field and press the jog dial to activate the menu.

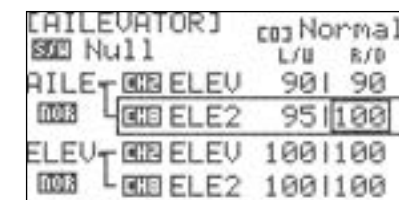

9. Scroll to highlight the "L/U" (left/up) field and press the jog dial to activate the menu.

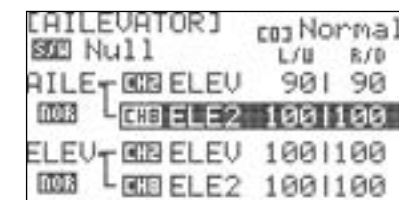

10. Rotate the jog dial to increase (clockwise) or decrease (counter-clockwise) the desired endpoint for the servo attached to the "RUDD" receiver slot. This value regards the servo travel when a left roll command is given. Press the jog dial to confirm your input.

11. Scroll to highlight the "R/D" (right/down) field and press the jog dial to activate the menu.

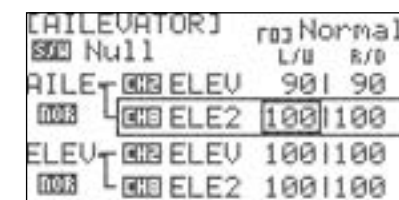

12. Rotate the jog dial to increase (clockwise) or decrease (counter-clockwise) the desired servo endpoint when a right roll command is given. Press the jog dial to confirm your input.

13. Press the back button to return to the ailevator Mix menu.

14. Repeat steps 2-13 using the lower "ELEV" and "ELE2" fields to set servo endpoints when pitch (elevator) commands are given.

15. If elevator and/or aileron functions operate in the incorrect direction, highlight the direction field ("nor") under the reversed function and press the jog dial to activate the menu.

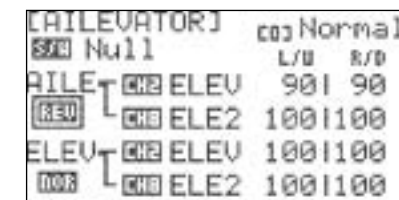

16. Push the back button twice to return to the model function menu.



Note

If you are using multiple flight conditions, you must define ailevator values for each flight condition. The top field of the AILEVATOR menu allows you to select the desired flight condition. Alternately, you may select the desired flight condition using the assigned F.Cond switch.

Aileron to Rudder Mixing

Many models (especially large-scale aircraft) fly through turns more smoothly when aileron and rudder commands are used simultaneously. The Aileron-Rudder mix will automatically apply rudder input when aileron commands are given.

To configure an aileron-rudder mix:

1. From the model menu, rotate the jog dial to highlight "AILE>RUDD" and press the jog dial once to enter the activation menu.

2. Press the jog dial again to activate the menu.

3. Rotate the jog dial to select "ACT" (activate), then press the jog dial to confirm your selection and activate the aileron-rudder mix menu.

4. Scroll to highlight the "RATE" field. Press the jog dial to activate the menu.

5. Rotate the jog dial to highlight either the "L/U" (left/up), the "R/D" (right/down) field, or both fields. If you want the rudder movements to be equal for both directions of aileron input (most common) highlight both fields and press the jog dial.

6. Rotate the jog dial to increase (clockwise) or decrease (counter-clockwise) the desired rudder travel when a left or right roll command is given. Press the jog dial to confirm your selection.

7. Scroll to highlight the "EXP" field and press the jog dial to activate the selection.

8. Rotate the jog dial to input the desired exponential travel of the rudder when reacting to this mix. The setting does not affect exponential travel when yaw commands are given.

9. Scroll to highlight the "OST" (Offset) field and press the jog dial to activate the menu.

10. Rotate the jog dial to set the increase/decrease amount of Offset for the rudder servo. Press the jog dial to confirm your selection.

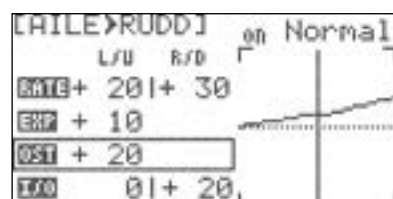
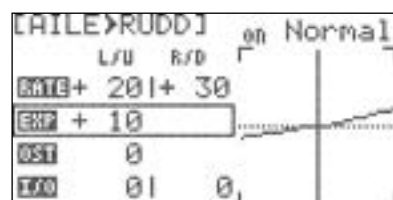
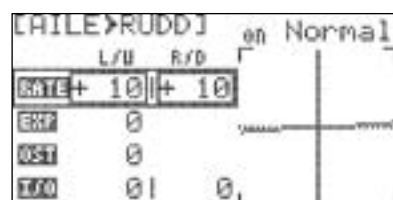
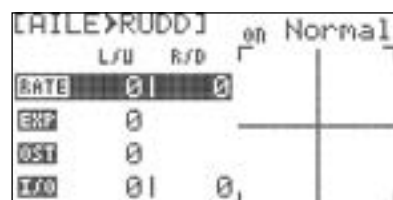
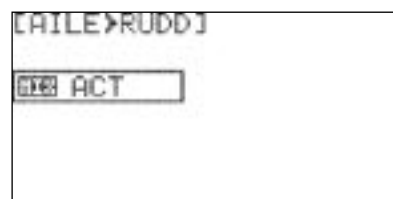

Aileron to Rudder Mixing cont.

11. The "I/O" (input/output) field is display only. It shows the value of the aileron and rudder channels as you actuate the aileron controls. These values are reflected in the graph as well.

12. Scroll to highlight the "SPEED" field and press the jog dial to activate the menu.

13. Rotate the jog dial to increase or decrease the transit time of the rudder servo (in seconds) when operating with the mix. Press the jog dial to confirm your input.

14. Scroll to highlight the "TRIM" field and press the jog dial to activate the menu.

15. Rotate the jog dial to select "ON" or "OFF" and press the jog dial to confirm your selection. When "ON" is selected, the mix reacts to trim adjustments of the ailerons. Otherwise, the mix ignores aileron trim changes.

16. Scroll to the "S/W" field and press the jog dial twice to activate the menu.

17. Scroll to select a switch to activate the mix. Press the jog dial to confirm your selection.

a. If you choose the "NULL" option, the mix will remain active at all times for this model.

b. If you choose a switch:

- The switch position menu will appear. Scroll to highlight the switch position that you will use to enable the mix. Press the jog dial to confirm your selection.

- Scroll to select "ON" and press the jog dial to confirm your selection. If you toggle the selected switch, the field in the top right corner of the screen will indicate when the mix is active.

18. Press the back button to return to the model function menu.

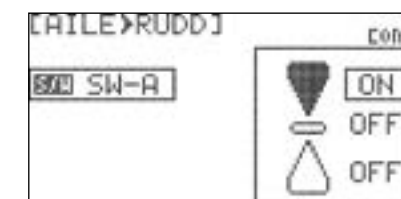
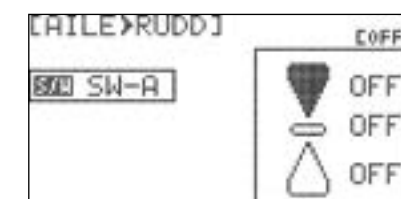
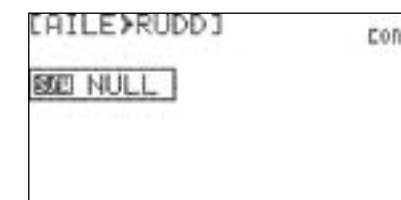
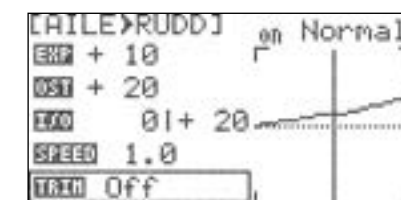
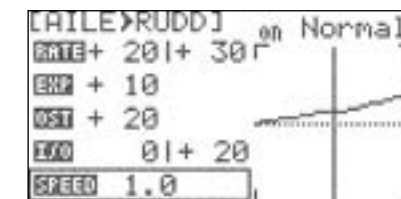

Aileron to Rudder Mixing cont.

19. To set up aileron to rudder mixing in accordance with a Flight Condition:

- The upper right field of the menu displays which flight condition is currently active and will be programmed.
- Scroll to the Flight Condition field and press the jog dial to activate the menu.
- Choose the desired flight condition and press the jog dial to confirm your selection.
- Repeat steps 4-18 to define the settings for each flight condition.

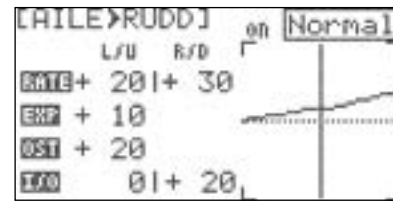

20. Press the back button to return to the model function menu.



If you are using multiple flight conditions, you must define aileron values for each flight condition. The top field of the AILEVATOR menu allows you to select the desired flight condition. Alternately, you may select the desired flight condition using the assigned F.Cond switch.

To disable the aileron-rudder mix:

1. Scroll to highlight the "MIX" field in the aileron-rudder mix menu and press the jog dial to activate the menu.
2. Select "INH" (inhibit) and press the jog dial to confirm your selection.
3. Press the back button to return to the model function menu.

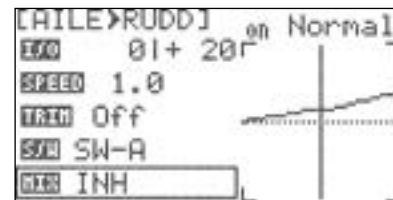

Elevator to Camber Mixing

The Elevator-to-Camber Mix allows the model to drop and raise the trailing edge of the wing control surfaces in conjunction with elevator inputs. This function is not valid for the "1AILE" or "ELEVON" wing types unless flaps are also present. If using a "1AILE + 1FLAP", "1AILE + 2FLAP", "ELEVON + 1FLP", or "ELEVON + 2FLP" wing type, do not configure any settings for the "AILE" function. Configure only flap servo movements.

To configure an elevator-to-camber mix:

1. From the model menu, rotate the jog dial to highlight "ELEV>CAMB" and press the jog dial once to enter the activation menu.
2. Press the jog dial again to activate the menu.
3. Rotate the jog dial to select "ACT" (activate), then press the jog dial to confirm your selection and activate the elevator-camber mix menu.

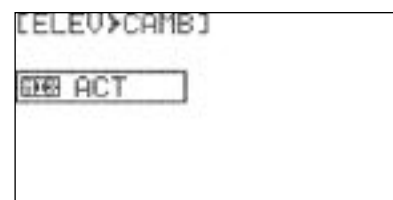

Elevator to Camber Mixing cont.

4. Scroll to the function field ("AILE" or "FLAP"). If "AILE" is not the current function, press the jog dial to activate the menu. Otherwise, skip to step 6.

5. Scroll to select "AILE" and press the jog dial to confirm your selection.

6. Scroll to the top row of the value table ("AILE") and press the jog dial to activate the menu.

7. Rotate jog dial to highlight "L/U" (Left/Up) "R/D" (Right/Down) or both fields. If you want the aileron movement to be the same for both directions of servo travel, highlight both fields and press the jog dial.

8. Rotate the jog dial to set the desired endpoints for the servo(s) attached to the "AILE" receiver slot. This value regards the servo travel when pitch commands are given. This setting does not affect the travel of the servo when roll commands are given. Press the jog dial to confirm your input.

9. Repeat steps 6-8 to set the endpoints for the servo attached to the "AIL2" receiver slot (second row of the value table). As with the previous settings, the values input here do not affect the servo travel when roll commands are given.

10. Scroll to highlight the "EXP" field and press the jog dial to activate the selection.

11. Rotate the jog dial to input the desired exponential travel of the aileron servos when reacting to this mix. The setting does not affect exponential travel of the servos when roll commands are given.

12. Scroll to highlight the "OST" (Offset) field and press the jog dial to activate the menu.

13. Rotate the jog dial to select the desired amount of offset and press the jog dial to enter your selection.

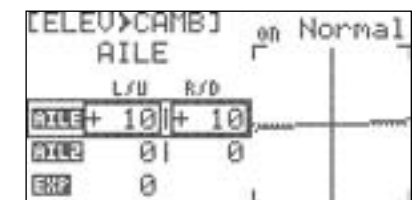
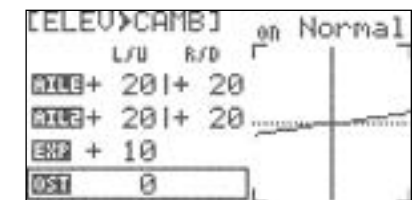
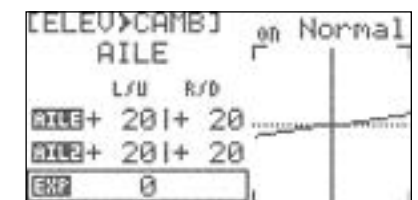
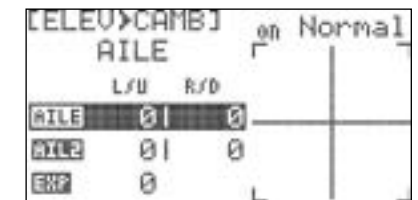
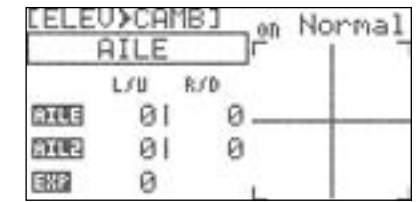

Elevator to Camber Mixing cont.

14. Scroll to highlight the "SPEED" field and press the jog dial to activate the menu.

15. Rotate the jog dial to increase or decrease the transit time of the wing servos (in seconds) when operating with the mix. Press the jog dial to confirm your input.

16. Scroll to highlight the "TRIM" field and press the jog dial to activate the menu.

17. Rotate the jog dial to select "ON" or "OFF" and press the jog dial to confirm your selection. When "ON" is selected, the mix reacts to trim adjustments of the elevator. Otherwise, the mix ignores elevator trim changes.

18. If the model is equipped with flaps, scroll to the function field ("AILE" or "FLAP") and press the jog dial to activate the menu. Otherwise, skip to step 21.

19. Rotate the jog dial to select "FLAP" and press the jog dial to confirm your selection.

20. Repeat steps 6-17 to configure the flap movements for this mix. If using only one flap servo, configure only the "FLAP" row of the value table. If using two flap servos, configure both rows of the value table.

21. Scroll to the "S/W" field and press the jog dial twice to activate the menu.

22. Rotate the jog dial to select a switch to activate the mix. Press the jog dial to confirm your selection.

a. If you choose the "NULL" option, the mix will remain active at all times for this model.

b. If you choose a switch:

- The switch position menu will appear. Scroll to highlight the switch position that you will use to enable the mix. Press the jog dial to confirm your selection.

- Scroll to select "ON" and press the jog dial to confirm your selection. If you toggle the selected switch, the field in the top right corner of the screen will indicate when the mix is active.

23. Press the back button to return to the model function menu.

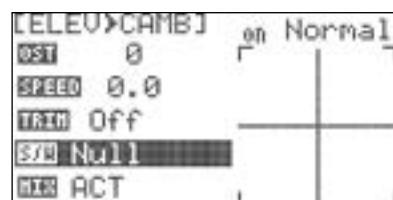
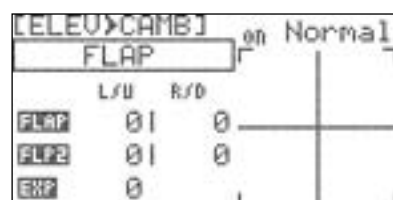
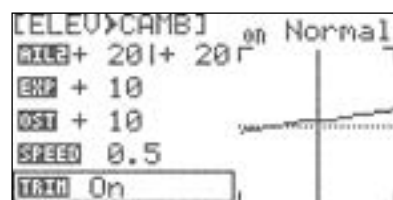
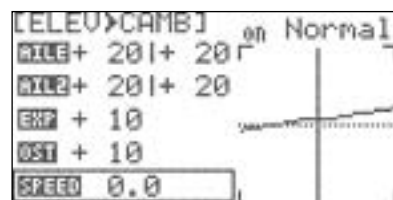

Elevator to Camber Mixing cont.

24. To set-up Elevator to Camber mixing in accordance with a Flight Condition:

- The upper right field of the menu displays which flight condition is currently active and will be programmed.
- Scroll to the Flight Condition field and press the jog dial to activate the menu.
- Choose the desired flight condition and press the jog dial to confirm your selection.

25. Press the back button to return to the model function menu.



Note

If you are using multiple flight conditions, you must define elevator-camber mix values for each flight condition. The top field of the ELEV-CAMB menu allows you to select the desired flight condition. Alternately, you may select the desired flight condition using the assigned F.Cond switch.

To disable the elevator-to-camber mix:

1. Scroll to highlight the "MIX" field in the elevator-camber mix menu and press the jog dial to activate the menu.
2. Select "INH" (inhibit) and press the jog dial to confirm your selection.
3. Press the back button to return to the model function menu.

Camber Mix

The Camber Mix feature allows you to define the camber of the wing airfoil by raising or lowering the wing control surfaces in unison. You may also adjust the elevator neutral position in each setting to maintain proper pitch trim.

To configure the camber mix:

1. From the Model menu, rotate the jog dial to highlight "Camber Mix" and press the jog dial once to enter the activation menu.
2. Press the jog dial again to activate the menu.
3. Rotate the jog dial to select "ACT" (activate), then press the jog dial to confirm your selection and activate the camber mix menu.
4. Scroll to highlight the "AILE" field and press the jog dial to activate the menu.
5. Rotate the jog dial to input the desired travel for the "AILE" servo when camber is active. Press the jog dial to conform your input.

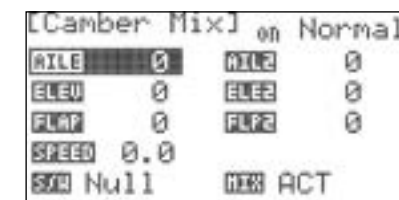
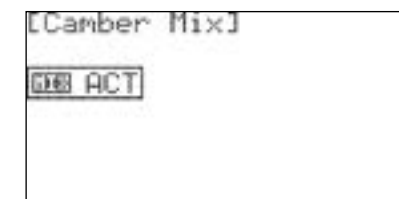
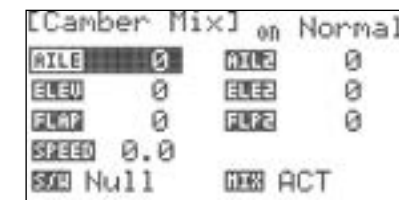
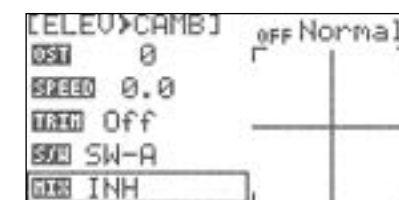
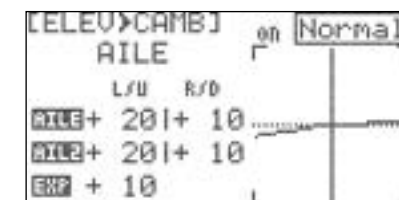

Camber Mix cont.

6. If the model has a second aileron servo, repeat step 5 in the "AIL2" field.

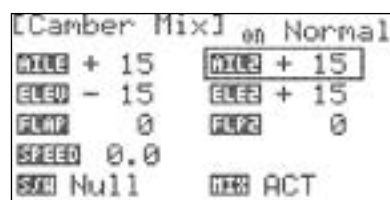

7. Scroll to highlight the "ELEV" field and press the jog dial to activate the menu.

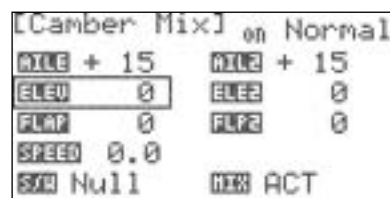

8. Rotate the jog dial to input the desired travel for the "ELEV" servo when camber is active. Press the jog dial to conform your input.

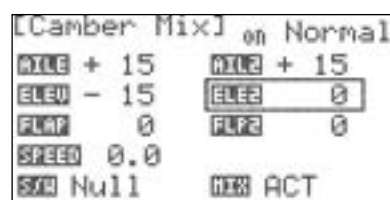

9. If the model has a second elevator servo, repeat step 8 in the "ELEV2" field.

10. Scroll to highlight the "FLAP" field and press the jog dial to activate the menu.

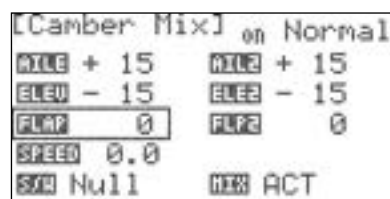

11. Rotate the jog dial to input the desired travel for the "FLAP" servo when camber is active. Press the jog dial to confirm your input.

12. If the model has a second flap servo, repeat step 11 in the "FLP2" field.

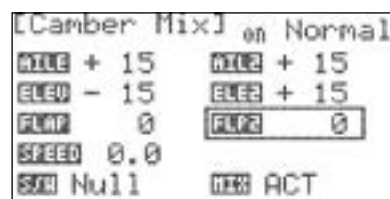

13. Scroll to highlight the "SPEED" field and press the jog dial to activate the menu.

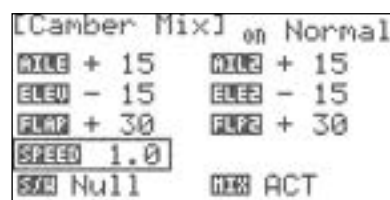

14. Rotate the jog dial to define the amount of time (0.0 to 10.0 seconds) for the camber settings to fully deploy. Press the jog dial to confirm your selection.

15. Scroll to the "S/W" field and press the jog dial twice to activate the menu.

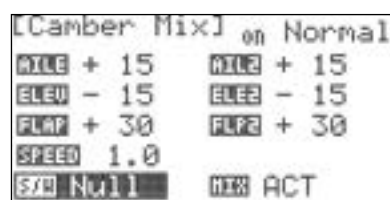

Camber Mixing cont.

16. Scroll to select a switch to activate the camber mix. Press the jog dial to confirm your selection.

a. If you choose the "NULL" option, the mix will remain inactive at all times for this model.

b. If you choose a switch:

- The switch position menu will appear. Scroll to highlight the switch position that you will use to enable the mix. Press the jog dial to confirm your selection.

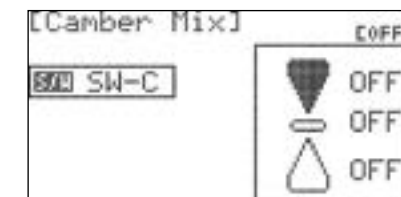

- Scroll to select "ON" and press the jog dial to confirm your selection. If you toggle the selected switch, the field in the top right corner of the screen will indicate when the mix is active.

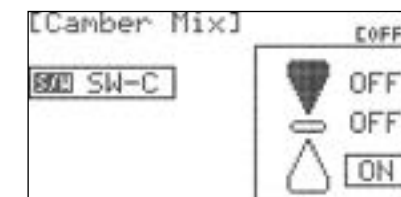

17. To set-up Camber Mixing in accordance with a Flight Condition

- The upper right field of the menu displays which flight condition is currently active and will be programmed.

- Scroll to the Flight Condition field and press the jog dial to activate the menu.

- Choose the desired flight condition and press the jog dial to confirm your selection.

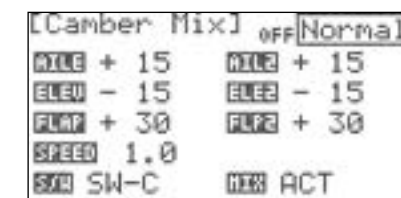

18. Press the back button to return to the model function menu.



Note

If you are using multiple flight conditions, you must define camber mix values for each flight condition. The top field of the Camber Mix menu allows you to select the desired flight condition. Alternately, you may select the desired flight condition using the assigned FCond switch.

To disable the camber mix:

1. Scroll to highlight the "MIX" field in the camber mix menu and press the jog dial to activate the menu.

2. Select "INH" (inhibit) and press the jog dial to confirm your selection.

3. Press the back button to return to the model function menu.

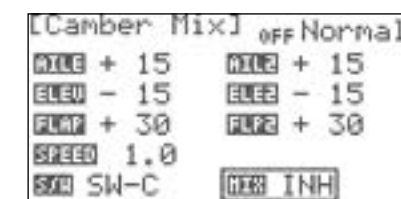

Flap Control

Flap Control is used to mix elevator control with flap movements. This is an effective way of avoiding pitch changes to the aircraft when flaps are deployed.

To configure flap control:

1. From the model menu, rotate the jog dial to highlight "FLAP CON" and press the jog dial once to enter the activation menu.

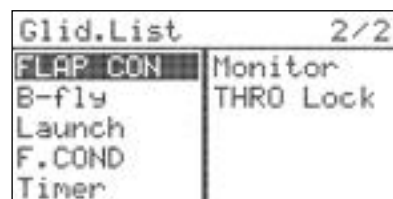

2. Press the jog dial again to activate the menu.

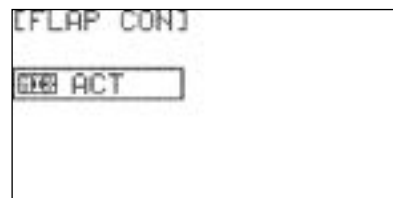

3. Rotate the jog dial to select "ACT" (activate), then press the jog dial to confirm your selection and activate the flap control menu.

4. Highlight the "FLAP" row of the value table and press the jog dial to activate the menu.

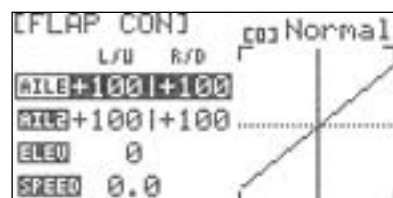

5. Scroll to highlight the "L/U" (left/up) field and press the jog dial to activate the menu.

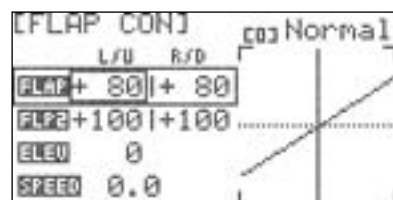

6. Rotate the jog dial to increase (clockwise) or decrease (counter-clockwise) the desired endpoint for the servo attached to the assigned flap channel. This value defines the end point when the flap is fully retracted. Set this value carefully to avoid any binding of the control linkages. Press the jog dial to confirm your input.

Note It is possible to select and adjust both the "L/U" (left/up) and "R/D" (right/down) fields simultaneously. However, with flaps, it is typically necessary to have asymmetric throw. So it is advisable to adjust each field independently.

7. Scroll to highlight the "R/D" (right/down) field and press the jog dial to activate the menu.



8. Rotate the jog dial to increase (clockwise) or decrease (counter-clockwise) the desired servo endpoint for the when the flap is fully deployed.

9. If the model has a second flap servo, repeat steps 4-8 on the "FLP2" row of the value table.

10. Press the back button to return to the flap control menu.

Flap Control cont.

11. Scroll to highlight the "ELEV" field and press the jog dial to activate the menu.

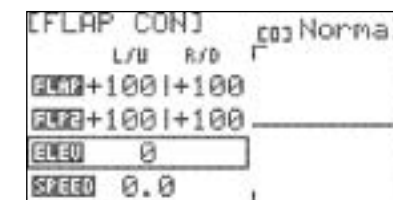

12. Rotate the jog dial to input the desired amount of elevator throw when the flaps are fully deployed. Press the jog dial to confirm your input. Most models require down elevator with flap deployment, which equates to positive values in this menu.



Tip Be sure to have the elevator servo(s) configured properly before performing the next step.

13. Scroll to highlight the "SPEED" field and press the jog dial to activate the menu.

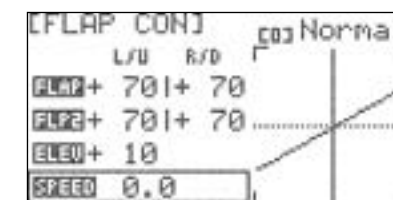

14. Scroll to define the amount of time (0.0 to 10.0 seconds) for the flaps and elevator mix to fully deploy. Press the jog dial to confirm your selection.

15. Scroll to the "S/W" field and press the jog dial to activate the menu.

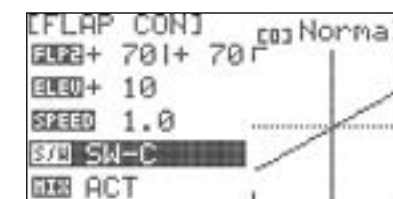

16. Rotate the jog dial to select a switch to activate the flap control. Press the jog dial to confirm your selection, if you choose the "NULL" option, the mix will remain inactive at all times for this model.

17. If you choose a switch you can check the switch position with the [0,1,2] next to the flight condition in the upper right corner of the screen



18. If you are using multiple flight conditions, you must define flap control values for each flight condition. The top field of the FLAP CON menu allows you to select the desired flight condition. Alternately, you may select the desired flight condition using the assigned F.Cond switch.

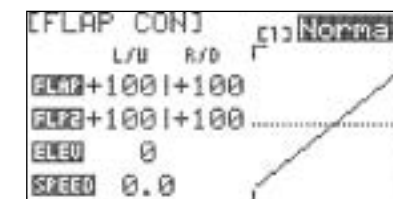

15. Press the back button to return to the model function menu.

Flap Control cont.

To disable flap control:

1. Scroll to highlight the "MIX" field in the flap control menu and press the jog dial to activate the menu.
2. Select "INH" (inhibit) and press the jog dial to confirm your selection.
3. Press the back button to return to the model function menu.

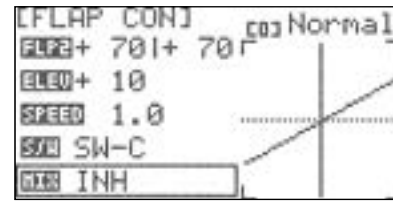

Landing

The Landing mix controls the ailerons, flaps, and elevator so they can act as an air brake that can dramatically reduce the landing distance of an aircraft.

1. From the model menu, rotate the jog dial to highlight "Landing" and press the jog dial once to enter the menu.
2. Press the jog dial to activate the menu.

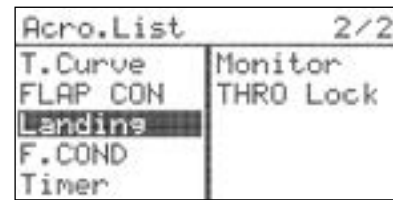

3. Rotate the jog dial to select "ACT" (activate), then press the jog dial to confirm your selection.

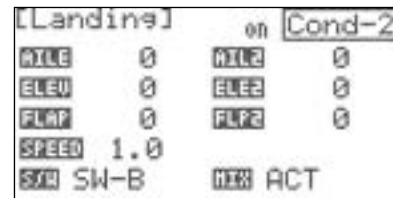

4. Scroll to highlight the "AILE" field and press the jog dial to activate the menu.

5. Rotate the jog dial to increase (clockwise) or decrease (counter-clockwise) the desired aileron servo angle when the mode activated. Press the jog dial to confirm your input.

6. If a second aileron set up for the airplane is needed, repeat steps 4 and 5 to change the "AILE2" value.

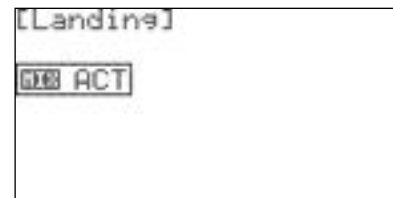

7. Scroll to highlight the "ELEV" field and press the jog dial to activate the menu.

8. Rotate the jog dial to increase (clockwise) or decrease (counter-clockwise) the desired elevator servo angle when the mode is activated. Press the jog dial to confirm your input.

9. If a second elevator set up for the airplane is needed, repeat the steps 7-8 to move "ELEV2" field.

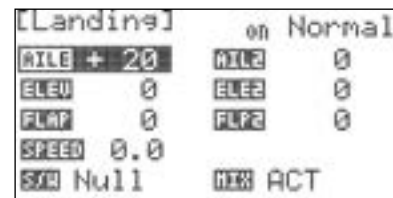

10. Scroll to highlight the "FLAP" field and press the jog dial to activate the menu.

11. Rotate the jog dial to increase (clockwise) or decrease (counter-clockwise) the desired flaperon servo angle when the mode activated. Press the jog dial to confirm your input.

Landing cont.

12. If a second flap set up for the aircraft is needed, repeat the steps 10 and 11 to change the "FLAP2" value.

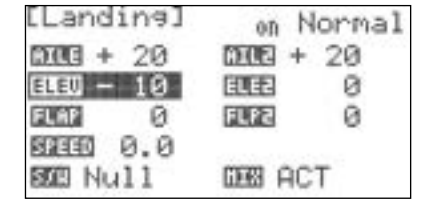

13. Rotate the jog dial to highlight "SPEED" and press the jog dial once to enter the menu. Rotate the jog dial to increase (clockwise) or decrease (counter-clockwise) the desired speed of landing function (0.0~10.0 sec) when the mode activated. Press the jog dial to confirm your input.

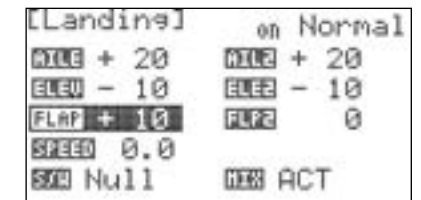

14. Scroll to highlight the "S/W" field and press the jog dial twice to activate the menu.

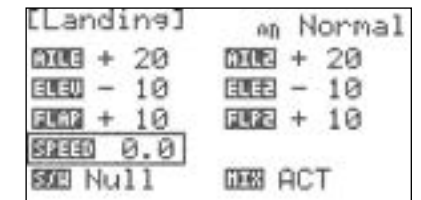

15. Rotate the jog dial to the desired switch that you will use for landing mix. Press the jog dial to confirm your input.

- a. If you choose the "NULL" option, the landing mix will remain active at all times for this model.

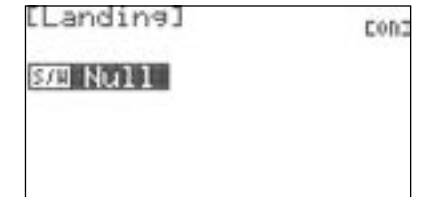

- b. If you choose a switch, scroll to highlight the switch position that you will use to enable ("ON") the mix. Press the jog dial to confirm your selection.

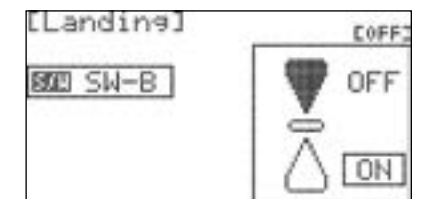

16. Set up in accordance with Flight Condition

- a. The upper right field of the menu displays which flight condition is currently active and will be programmed.

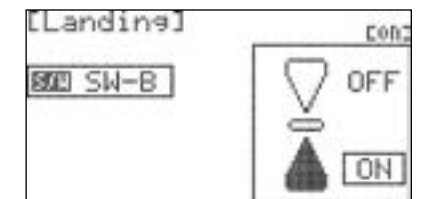

- b. Scroll to the Flight Condition field and press the jog dial to activate the menu.

- c. Choose the desired flight condition and press the jog dial to confirm your selection.

Landing cont.

To disable the landing mix:

1. Scroll to highlight the "MIX" field in the landing mix menu and press the jog dial to activate the menu.
2. Select "INH"(inhibit) and press the jog dial to confirm your selection.
3. Press the back button to return to the model menu.

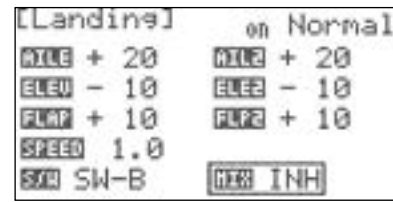

Butterfly Mixing (B. FLY GLID Only)

B-fly (Butterfly, also called "crow") mixing configures the wing control surfaces to act as an air brake by dropping the flaps and raising the ailerons. You may also program elevator throw to maintain pitch trim. This mix is often used to slow slippery gliders for landing. The mix is usually activated with the linear action of the throttle stick.

To configure butterfly:

1. From the model menu, rotate the jog dial to highlight "B-fly" and press the jog dial once to enter the activation menu.
2. Press the jog dial again to activate the menu.
3. Rotate the jog dial to select "ACT" (activate), then press the jog dial to confirm your selection and activate the butterfly menu.
4. Scroll to highlight the "AILE" field and press the jog dial to activate the menu.
5. Rotate the jog dial to input the desired travel for the "AILE" servo when Butterfly is active. Press the jog dial to confirm your input.
6. If the model has a second aileron servo, repeat step 5 in the "AIL2" field.

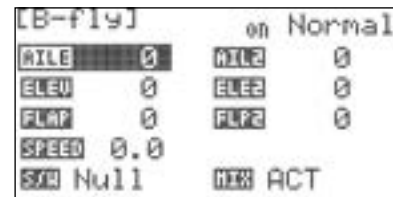
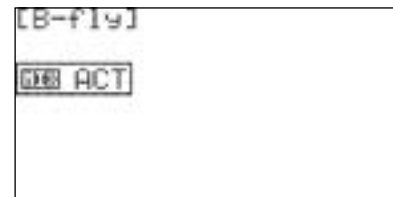

Butterfly Mixing (B. FLY GLID Only)\) cont.

7. Scroll to highlight the "ELEV" field and press the jog dial to activate the menu.
8. Rotate the jog dial to input the desired travel for the "ELEV" servo when Butterfly is active. Press the jog dial to confirm your input.
9. If the model has a second elevator servo, repeat step 8 in the "ELE2" field.
10. Scroll to highlight the "FLAP" field and press the jog dial to activate the menu.
11. Rotate the jog dial to input the desired travel for the "FLAP" servo when Butterfly is active. Press the jog dial to confirm your input.
12. If the model has a second flap servo, repeat step 11 in the "FLP2" field.
13. Press the back button to return to the B. FLY menu.
14. Scroll to highlight the "SPEED" field and press the jog dial to activate the menu.
15. Scroll to define the amount of time (0.0 to 10.0 seconds) for the butterfly mix to fully deploy. Press the jog dial to confirm your selection.
16. Scroll to the "S/W" field and press the jog dial twice to activate the menu.

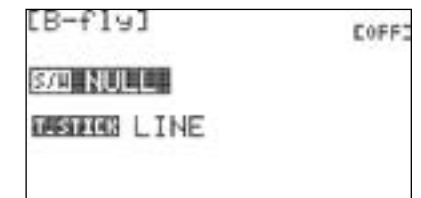
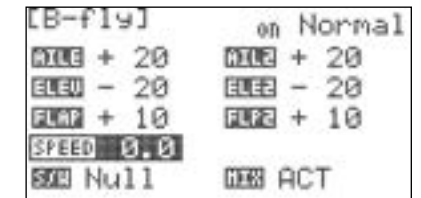
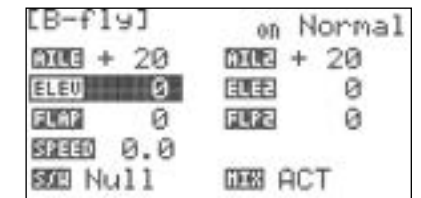
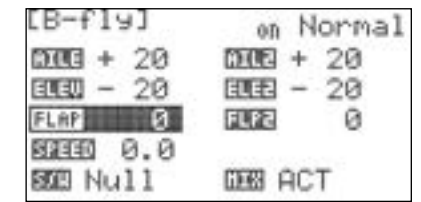

17. Scroll to select a switch to activate the butterfly mix. Press the jog dial to confirm your selection.
 - a. If you choose the "NULL" option, the butterfly mix will remain inactive at all times for this model.
 - b. If you choose a switch:
 - The switch position menu will appear. Scroll to highlight the switch position that you will use to enable the mix. Press the jog dial to confirm your selection.

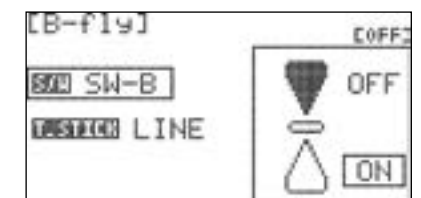

Butterfly Mixing (B. FLY GLID Only) cont.

- Scroll to select "ON" and press the jog dial to confirm your selection. If you toggle the selected switch, the field in the top right corner of the screen will indicate when the mix is active.

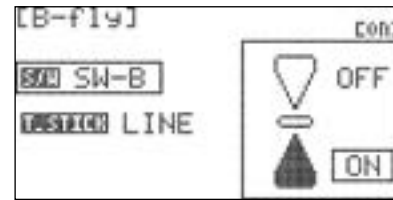

18. Scroll to highlight the "T.STICK" field and press the jog dial to activate the menu.

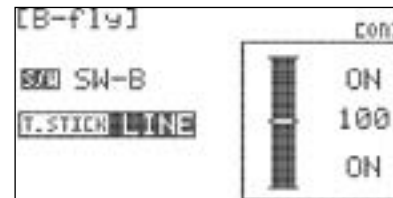

19. Scroll to select the movement type for the throttle stick. Press the jog dial to confirm your selection.

a. If you choose "LINE" (linear) the mix will be applied proportionally to throttle position. For fully linear movement, verify that the throttle position menu shows the mix to be on at both ends of the throttle range, and the middle value is "100".

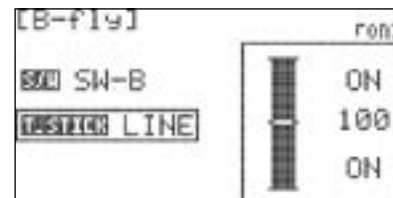

The SPEED value is ignored when linear movement is selected.

b. If you choose "SYM." (symmetric), the mix will be applied fully when the throttle position crosses a defined threshold:

- The throttle position menu will appear. Scroll to highlight the throttle position that you will use to enable the mix. Press the jog dial to confirm your selection.

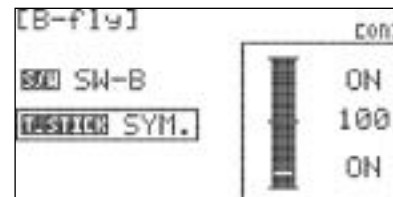

- Scroll to select "ON" and press the jog dial to confirm your selection.

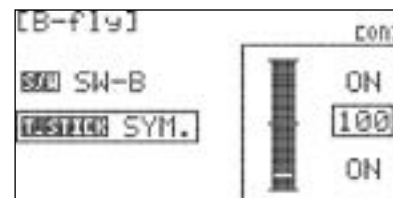

- Scroll to select the middle value field and press the jog dial to activate the menu.

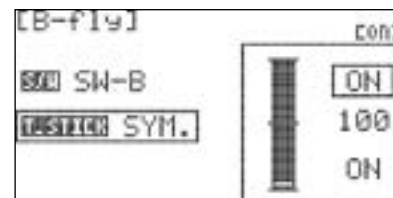

- Rotate the jog dial to position the top of the bar graph at the throttle position where the mix will be enabled. As you move the throttle stick, the field in the top right corner of the screen will indicate when the mix is active.

20. Press the back button four times to return to the model function menu.

Butterfly Mixing (B. FLY GLID Only) cont.



If you are using multiple flight conditions, you must define butterfly values for each flight condition. The top field of the B-fly menu allows you to select the desired flight condition. Alternately, you may select the desired flight condition using the assigned F.Cond switch.

To disable butterfly:

1. Scroll to highlight the "MIX" field in the butterfly menu and press the jog dial to activate the menu.

2. Select "INH" (inhibit) and press the jog dial to confirm your selection.

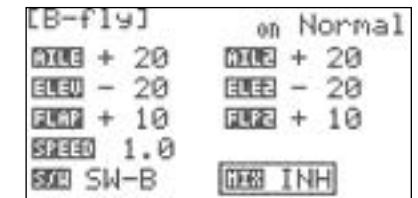

3. Press the back button to return to the model function menu.

Gyro

It is often desirable to use a gyro to help stabilize one or more flight axes on fixed-wing models. The Flash 8 provides controls for gyros in three axes. The gyro settings can also be specified for each defined flight condition.



The GYRO function must be assigned to a channel before this option will appear in the Model function menu. See Section 3 for instructions regarding the Channel menu.

1. From the model menu, rotate the jog dial to highlight "GYRO" and press the jog dial once to enter the activation menu.

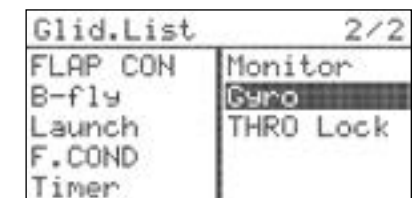

2. Press the jog dial again to activate the menu.

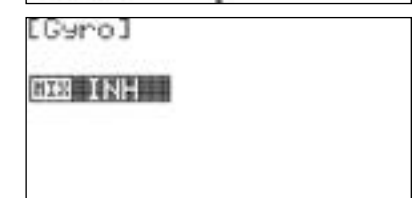

3. Rotate the jog dial to select "ACT" (activate), then press the jog dial to confirm your selection and activate the gyro menu.

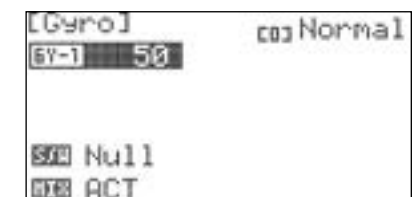

4. Scroll to the "GY-1" field and press the jog button to activate the menu.

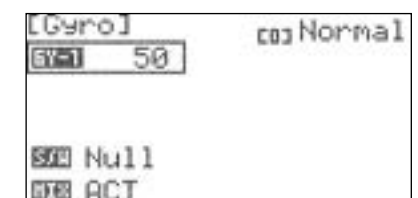

5. Rotate the jog dial to dial in the desired amount of gyro gain for the Gyro-1 axis (consult the gyro manufacturer's instructions for guidance).

6. Repeat steps 4 and 5 for any other gyro axes listed.

Gyro cont.

7. Scroll to highlight "S/W" and press the jog dial to activate the switch menu.

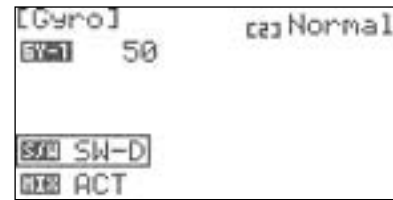

8. Rotate the jog dial to select a switch to control the gyro. Press the jog dial to confirm your selection.

a. If you choose the "NULL" option, the set gyro rate will remain active at all times for this model.

b. If you choose a switch:

- The current switch position will be displayed in the top right field of the display as "0", "1", or "2".

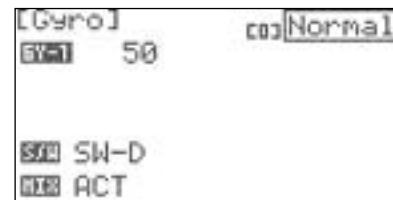

- Repeat steps 4 and 5 to define gyro rate for every switch position.



Note

If you are using multiple flight conditions, you must define gyro values for each flight condition. The top field of the Gyro menu allows you to select the desired flight condition. Alternately, you may select the desired flight condition using the assigned F.Cond switch.

9. Press the back button to return to the model function menu.

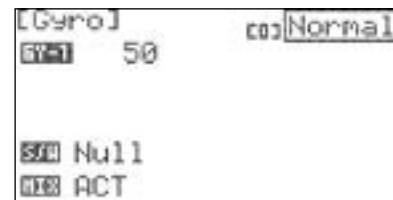

10. To set-up the Gyro in accordance with a Flight Condition

- The upper right field of the menu displays which flight condition is currently active and will be programmed.

- Scroll to the Flight Condition field and press the jog dial to activate the menu.

- Choose the desired flight condition and press the jog dial to confirm your selection.

11. Press the back button to return to the model function menu.

To disable the gyro:

1. Scroll to highlight the "MIX" field in the gyro menu and press the jog dial to activate the menu.

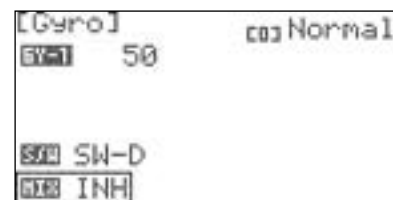

2. Select "INH" (inhibit) and press the jog dial to confirm your selection.

3. Press the back button to return to the model function menu.

Throttle Cut (Acro Only)

Throttle Cut is a vital safety feature when flying glow or gas-powered models. This feature will command the throttle servo to a preprogrammed position with a switch movement. You may choose to set the servo to bring the engine to low-idle, or even shut it down.

To configure throttle cut:

1. From the model menu, rotate the jog dial to highlight "THRO CUT" and press the jog dial once to enter the activation menu.



2. Press the jog dial again to activate the menu.

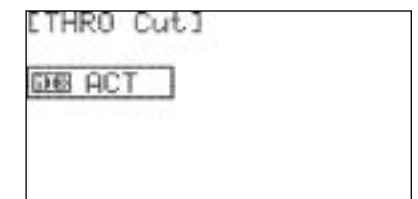

3. Rotate the jog dial to select ACT (activate), then press the jog dial to confirm your selection and activate the throttle cut menu.

4. Scroll to the "POS" (position) field and press the jog button to activate the menu.

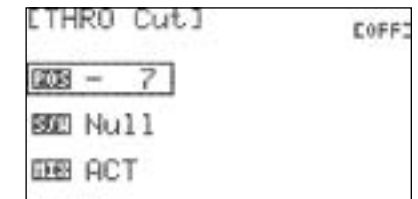

5. Rotate the jog dial to input the desired position of the throttle servo when throttle cut is activated. Models will typically require negative values to set a "kill engine" position. Ensure that the selected position does not cause the throttle servo to bind or place stress on the carburetor's control arm.

6. Scroll to highlight "S/W" and press the jog dial to activate the switch menu.

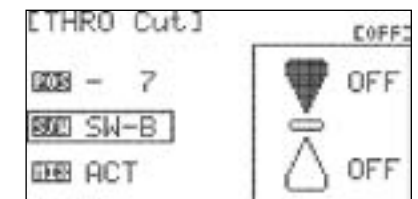

7. Scroll to select a switch to activate throttle cut. Press the jog dial to confirm your selection.

a. If you choose the "NULL" option, throttle cut will remain inactive at all times for this model.

b. If you choose a switch:

- The switch position menu will appear. Scroll to highlight the switch position that you will use to enable throttle cut. Press the jog dial to confirm your selection.

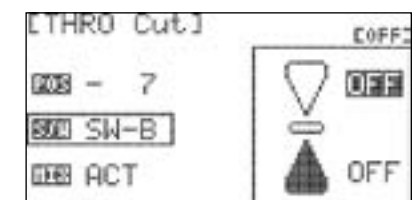

Throttle Cut (Acro Only) cont.

- Scroll to select "ON" and press the jog dial to confirm your selection. If you toggle the selected switch, the field in the top right corner of the screen will indicate when the mix is active.

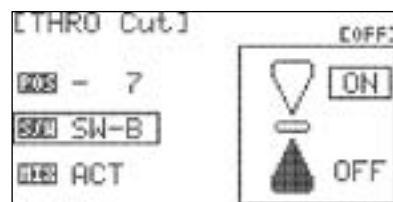

Tip The momentary "deadman" switch (Switch-H) is a convenient and commonly-used throttle cut switch. Throttle cut should be off when the switch is in its neutral position.

8. Press the back button to return to the model function menu.

To disable throttle cut:

1. Scroll to highlight the "MIX" field in the throttle cut menu and press the jog dial to activate the menu.

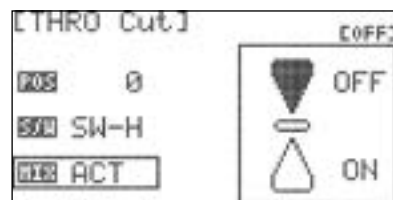

2. Select "INH" (inhibit) and press the jog dial to confirm your selection.

3. Press the Back button to return to the model function menu.

Throttle Curve (Acro Only)

The Throttle Curve function allows you to modify the normally-linear servo rate movement for throttle by defining five different points along the throttle response curve.

To configure a throttle curve:

1. From the model menu, rotate the jog dial to highlight "T.Curve" and press the jog dial once to enter the activation menu.

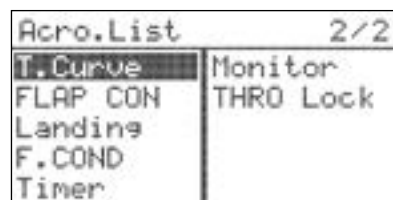

2. Press the jog dial again to activate the menu.

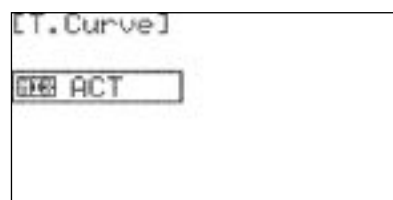

3. Rotate the jog dial to select ACT (activate), then press the jog dial to confirm your selection and activate the throttle curve menu.

Throttle Curve (Acro Only) cont.

4. Scroll to the "1" field and press the jog button to activate the menu.

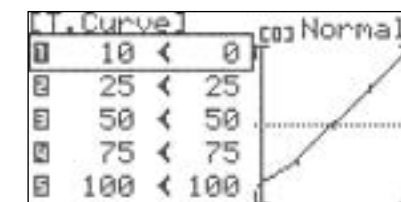

5. Rotate the jog dial to input the desired throttle position at this point on the curve (Throttle stick full down).

6. Scroll to highlight the "2" field and press the jog dial to activate.

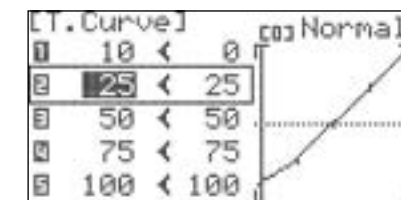

7. Rotate the jog dial to set the desired value of "Y" axis on the left when right roll command is given. Press the jog dial to confirm your input.

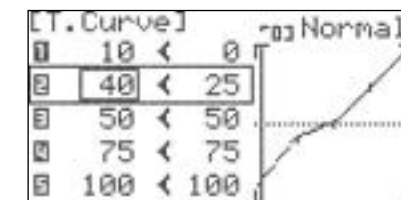

10. Scroll to the "EXP" (exponential) field and press the jog button to activate the menu.

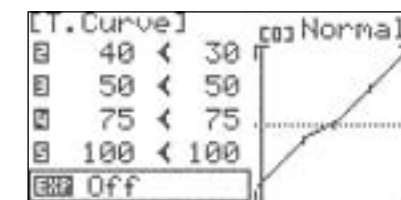

11. Rotate the jog dial to select "OFF" or "ON". When "ON" is selected, the points in the curve are connected with exponential curves. Otherwise, the points are joined linearly. Press the jog dial to confirm your selection.

12. Scroll to highlight the "OST" (Offset) field and press the jog dial to activate the menu.

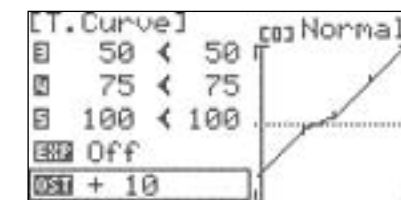

13. Scroll to select the desired amount of offset and press the jog dial to enter your selection.

14. Scroll to highlight "S/W" and press the jog dial to activate the switch menu.

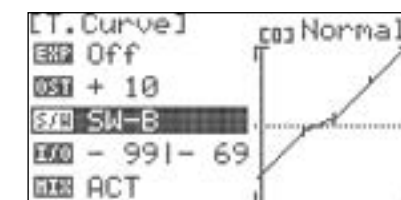

Throttle Curve cont.

15. Rotate the jog dial to select a switch to activate the throttle curve. Press the jog dial to confirm your selection.

a. If you choose the "NULL" option, throttle cut will remain inactive at all times for this model.

b. If you choose a switch:

- The switch position menu will appear. The current switch position will be displayed in the top right field of the display as "0", "1", or "2"

- Repeat steps 4-8 to define throttle curve for every switch position.

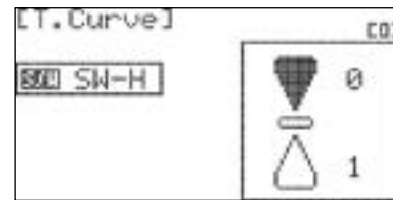

Note If you are using multiple flight conditions, you must define throttle curve values for each flight condition. The top field of the T.Curve menu allows you to select the desired flight condition. Alternately, you may select the desired flight condition using the assigned F.Cond switch.

16. To set-up the Throttle Curve in accordance with a Flight Condition:

- The upper right field of the menu displays which flight condition is currently active and will be programmed.
- Scroll to the Flight Condition field and press the jog dial to activate the menu.
- Choose the desired flight condition and press the jog dial to confirm your selection.

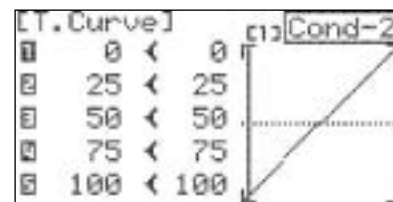

17. Press the back button to return to the model function menu.

18. The "I/O" (input/output) field is display only. It shows the value of the throttle channel as you actuate the throttle control. These values are reflected in the graph as well.

19. Press the back button to return to the model function menu.

To disable the throttle curve:

1. Scroll to highlight the "MIX" field in the throttle curve menu and press the jog dial to activate the menu.
2. Select "INH" (inhibit) and press the jog dial to confirm your selection.
3. Press the back button to return to the model function menu.

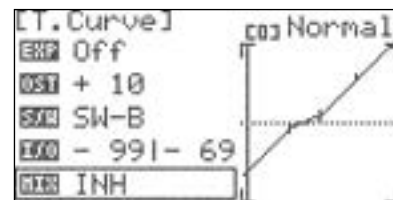

Helicopter Programming Menu

When the active model is configured as a helicopter model type, the model function menu contains programming options which are useful for helicopters. This section describes the features and programming steps for the helicopter model function menu.

Tip If you have not already programmed a model with the preceding quick start guide, we encourage you to do so before tackling the model programming section of the manual.

From the model function menu, you can program the following helicopter-specific options:

GYRO: Specify gyro on/off and sensitivity settings.

THRO CUT: Configure a kill switch for glow/gas motors.

T.HOLD: Set a switch-controlled throttle position.

REVO MIX: Damp unintended yaw movement when not using a heading hold gyro.

SWASH>THRO: Mix throttle with swashplate movements.

Swash Mix: Apply fine adjustments to the swash plate travel.

T.Curve: Specify non-linear throttle response.

P.Curve: Configure optimum blade pitch for different throttle settings.

FLT.COND: Configure specific control settings for different phases of flight.

***Swash Ring:** Prevent excessive control throw on the swash servos.

THRO Lock: Assign a switch to lock and release throttle movements.

Working with Heli Model Function Menu

1. Turn on transmitter. When prompted to transmit, select "NO".
2. Verify that the active model is a helicopter.
3. To access the model function menu, press and hold the jog dial.
4. The menu options shown reflect the parameters defined for the active model in the model type menu (Model Type and Swash). HELI-specific items are integrated in the menu with the options that are common to all model types.

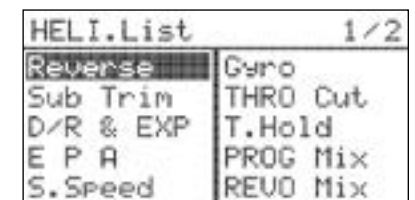

Gyro

It is often desirable to use a gyro to help stabilize the tail rotor on helicopters. The Flash 8 provides up to three gyro sensitivity settings per model memory. The gyro settings can also be specified for each defined flight condition.

Tip The GYRO function must be assigned to a channel before this option will appear in the Model function menu. See Section 3 for instructions regarding the Channel menu.

Gyro cont.

1. From the Model menu, rotate the jog dial to highlight “GYRO” and press the jog dial once to enter the activation menu.

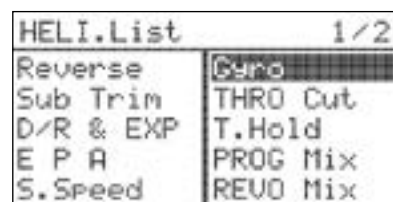

2. Press the jog dial again to activate the menu.

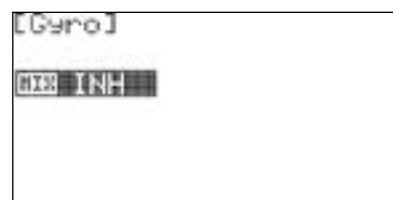

3. Rotate the jog dial to select ACT (activate), then press the jog dial to confirm your selection and activate the GYRO menu.

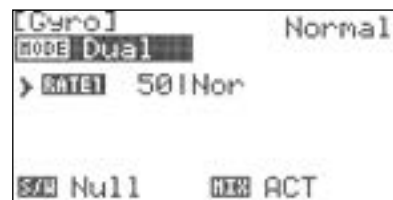

4. Scroll to the “MODE” field and press the jog button to activate the menu.

5. Rotate the jog dial to select “Single” or “Dual” to denote whether your gyro is a single-rate or dual-rate unit. Consult the gyro manufacturer’s instructions if you are not sure. Press the jog dial to confirm your selection.

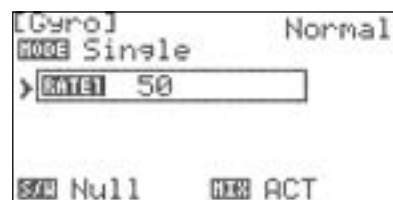

a. If you choose “Single”:

- Scroll to the “RATE1” field and press the jog button to activate the menu.

- Rotate the jog dial to dial in the desired amount of gyro gain (consult the gyro manufacturer’s instructions for guidance).

b. If you choose “Dual”:

- Scroll to the “RATE1” field and press the jog button to activate the menu.

- Scroll to highlight the value field and press the jog dial to activate the menu.

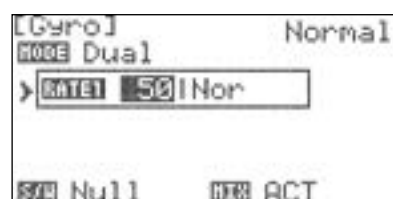

- Rotate the jog dial to dial in the desired amount of gyro gain (consult the gyro manufacturer’s instructions for guidance).

- Rotate the jog dial to highlight the function field (“Nor” or “T.lock”) and press the jog dial to activate the menu.

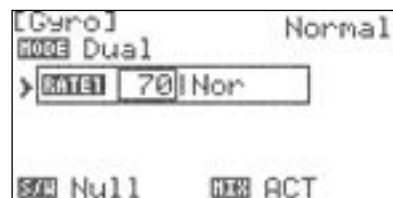

- Rotate the jog dial to select “Nor” (normal) or “T.lock” (throttle lock). Throttle lock is used for bench testing the gyro rate sensitivity.

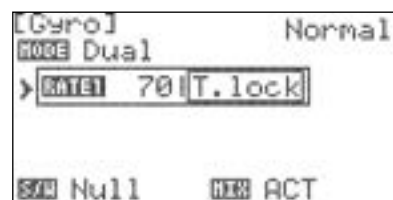

Gyro cont.

6. Scroll to highlight “S/W” and press the jog dial to activate the switch menu.



7. Rotate the jog dial to select a switch to activate the camber mix. Press the jog dial to confirm your selection.

a. If you choose the “NULL” option, the set gyro rate will remain active at all times for this model.

b. If you choose a switch:

- The current switch position will be displayed in the top right field of the display as “0”, “1”, or “2”.

- Repeat step 5a or 5b as applicable to define gyro rate for every switch position.

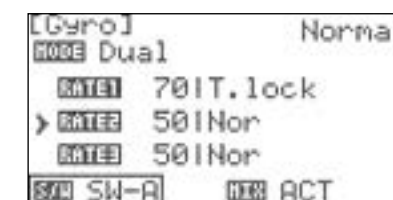

8. To set up the Gyro in accordance with a Flight Condition

– The upper right field of the menu displays which flight condition is currently active and will be programmed.

– Scroll to the Flight Condition field and press the jog dial to activate the menu.

– Choose the desired flight condition and press the jog dial to confirm your selection.

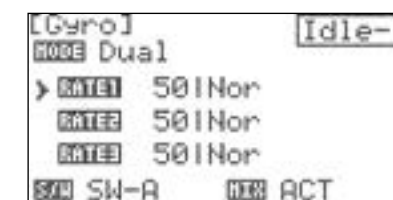

Note

If you are using multiple flight conditions, you must define gyro values for each flight condition. The top field of the Gyro menu allows you to select the desired flight condition. Alternately, you may select the desired flight condition using the assigned F.Cond switch.

9. Press the Back button to return to the Model Function menu.

To disable the Gyro:

1. Scroll to highlight the “MIX” field in the Gyro menu and press the jog dial to activate the menu.

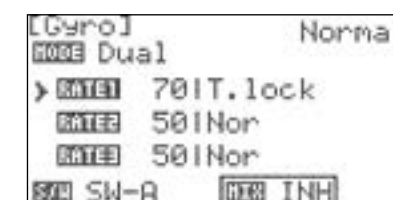

2. Select “INH” (inhibit) and press the jog dial to confirm your selection.

3. Press the Back button to return to the Model Function menu.

Throttle Cut

Throttle Cut is a vital safety feature when flying glow or gas-powered models. This feature will command the throttle servo to a preprogrammed position with a switch movement. You may choose to set the servo to bring the engine to low-idle, or even shut it down.

To configure throttle cut:

1. From the model menu, rotate the jog dial to highlight "THRO CUT" and press the jog dial once to enter the activation menu.

2. Press the jog dial again to activate the menu.

3. Rotate the jog dial to select ACT (activate), then press the jog dial to confirm your selection and activate the throttle cut menu.

4. Scroll to the "POS" (position) field and press the jog button to activate the menu.

5. Rotate the jog dial to input the desired position of the throttle servo when throttle cut is activated. Models will typically require negative values to set a "kill engine" position. Ensure that the selected position does not cause the throttle servo to bind or place stress on the carburetor's control arm.

6. Scroll to highlight "S/W" and press the jog dial to activate the switch menu.

7. Scroll to select a switch to activate the camber mix. Press the jog dial to confirm your selection.

a. If you choose the "NULL" option, throttle cut will remain inactive at all times for this model.

b. If you choose a switch:

- The switch position menu will appear. Scroll to highlight the switch position that you will use to enable throttle cut. Press the jog dial to confirm your selection.

- Scroll to select "ON" and press the jog dial to confirm your selection. If you toggle the selected switch, the field in the top right corner of the screen will indicate when the mix is active.

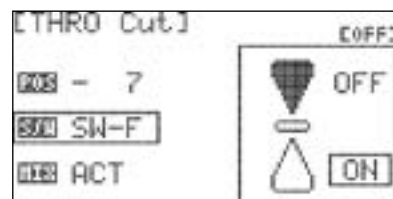
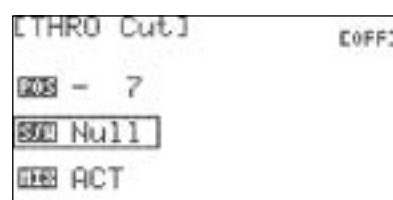
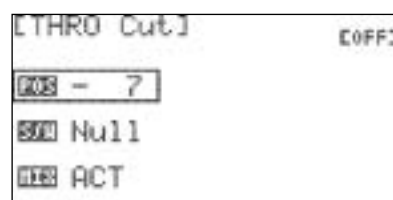
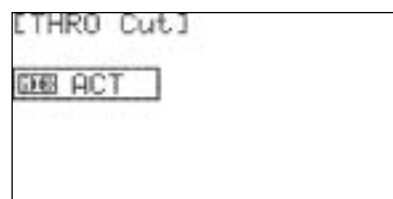

The momentary "deadman" switch (Switch-H) is a convenient and commonly-used throttle cut switch. Throttle cut should be off when the switch is in its neutral position.

Throttle Cut cont.

8. To disable Throttle Cut:

- Scroll to highlight the "MIX" field in the Throttle Cut menu and press the jog dial to activate the menu.

- Select "INH" (inhibit) and press the jog dial to confirm your selection.

- Press the Back button to return to the Model Function menu.

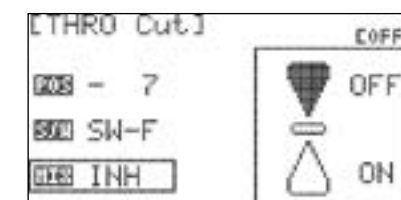

Throttle Hold

Throttle hold is used to set the throttle at a programmed position while still allowing the throttle stick to control blade pitch. This function is often used to facilitate auto-rotation maneuvers.



The throttle hold feature will not work unless a hold position has been assigned a switch using the flight condition/idle-up function as was done on page 107.

1. From the Model menu, rotate the jog dial to highlight T.HOLD and press the jog dial once to enter the activation menu.

2. Press the jog dial again to activate the menu.

3. Rotate the jog dial to select ACT (activate), then press the jog dial to confirm your selection and activate the T.Hold menu.

4. Scroll to the "RATE" field and press the jog button to activate the menu.

5. Use the jog dial to place a rate value for the hold position you want the throttle to be at when the hold switch is activated.

To disable the T.HOLD function:

1. Scroll to highlight the "MIX" field in the T.HOLD menu and press the jog dial to activate the menu.

2. Select "INH" (inhibit) and press the jog dial to confirm your selection.

3. Press the Back button to return to the Model Function menu.

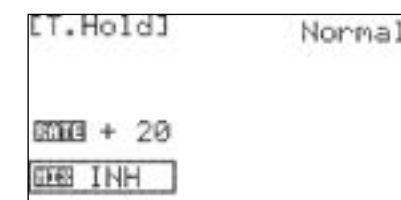
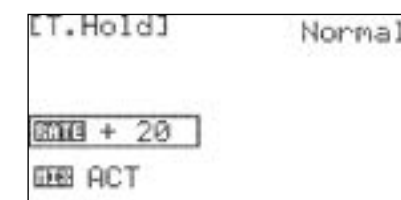
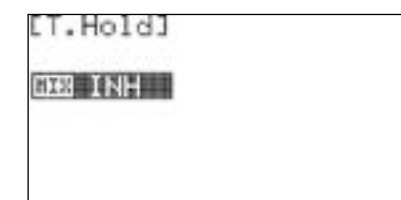

Revolution Mixing

The revolution mix is used to prevent yaw effects caused by changes in head speed or blade pitch on the main rotor. The Flash 8 allows a five point curve to be set. It is not needed on helicopters equipped with a heading hold gyro.

To configure a revolution mix:

1. From the Model menu, rotate the jog dial to highlight "REVO Mix" and press the jog dial once to enter the activation menu.



2. Press the jog dial again to activate the menu.

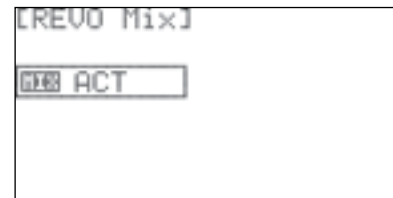

3. Rotate the jog dial to select ACT (activate), then press the jog dial to confirm your selection and activate the GYRO menu.

4. Scroll to the "1" field and press the jog button to activate the menu.

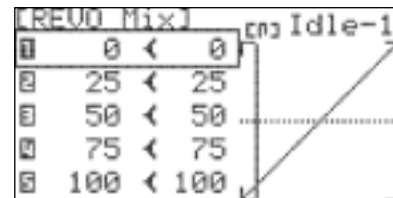

5. The left field is the tail rotor pitch and the right field is the throttle position. Highlight each field individually and input the desired values for the first point of the curve.

6. Scroll to the "2" field and press the jog button to activate the menu.

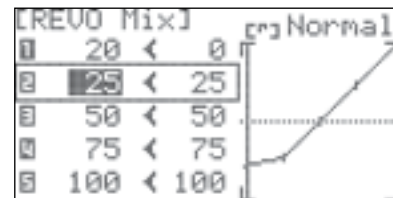

7. The left field is the tail rotor pitch and the right field is the throttle position. Highlight each field individually and input the desired values for the first point of the curve.

8. Press the back button to return to the REVO Mix menu.

Revolution Mixing cont.

9. Repeat steps 4-8 to input the values for each point of the mix curve.

10. Press the back button to return to the REVO Mix menu.

11. Scroll to highlight the "EXP" field and press the jog dial to activate the menu.

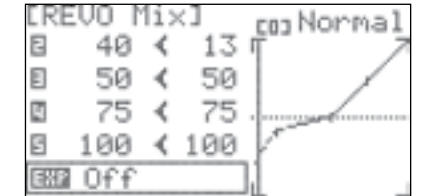

12. Rotate the jog dial to increase (clockwise) or decrease (counter-clockwise) the desired exponential value for this mix. This value does not affect exponential throw of the servo with rudder stick commands. Press the jog dial to confirm your input.

13. Scroll to highlight the "OST" (Offset) field and press the jog dial to activate the menu.

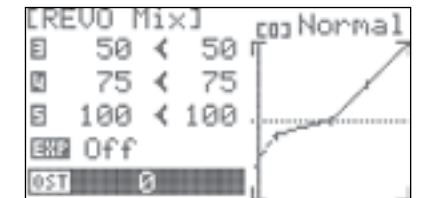

14. Scroll to select the desired amount of offset and press the jog dial to enter your selection.

15. Scroll to highlight "S/W" and press the jog dial to activate the switch menu.

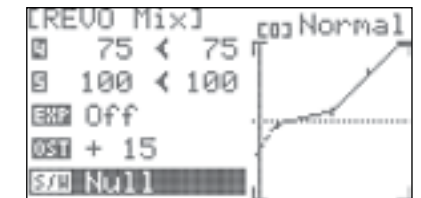

16. Scroll to select a switch to activate the camber mix. Press the jog dial to confirm your selection.

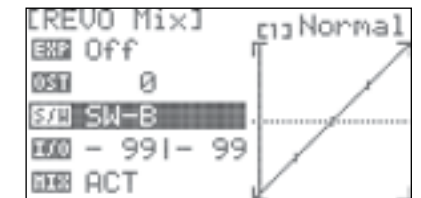

a. If you choose the "NULL" option, revolution mix will remain active at all times for this model.

Revolution Mixing cont.

b. If you choose a switch:

- The switch position menu will appear. Scroll to highlight the switch position that you will use to enable revolution mix. Press the jog dial to confirm your selection.

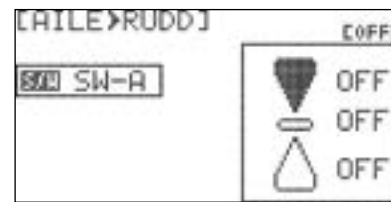

- Scroll to select "ON" and press the jog dial to confirm your selection. If you toggle the selected switch, the field in the top right corner of the screen will indicate when the mix is active.

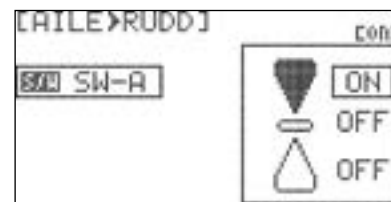

17. The "I/O" (input/output) field is display only. It shows the value of the tail rotor pitch and throttle as you actuate the controls. These values are reflected in the graph as well.

18. To set up the Revo Mix in accordance with a Flight Condition:

- The upper right field of the menu displays which flight condition is currently active and will be programmed.
- Scroll to the Flight Condition field and press the jog dial to activate the menu.
- Choose the desired flight condition and press the jog dial to confirm your selection.

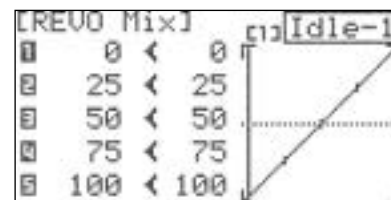

19.. Press the Back button to return to the Model Function menu.



Note

If you are using multiple flight conditions, you must define REVO Mix values for each flight condition. The top field of the REVO Mix menu allows you to select the desired flight condition. Alternately, you may select the desired flight condition using the assigned F.Cond switch.

To disable the revolution mix:

1. Scroll to highlight the "MIX" field in the Revolution Mix menu and press the jog dial to activate the menu.

2. Select "INH" (inhibit) and press the jog dial to confirm your selection.

3. Press the Back button to return to the Model Function menu.

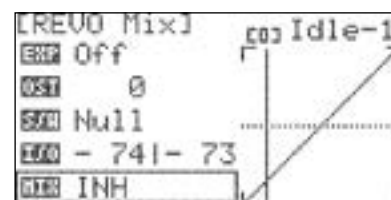

Swash to Throttle Mixing

A swash to throttle mix is typically used to increase main rotor RPM when a swash control command is input to the helicopter. The increased RPM compensates for the loss of lift due to tilting the rotor.

1. From the Model menu, rotate the jog dial to highlight "SWASH>THRO" and press the jog dial once to enter the activation menu.



2. Press the jog dial again to activate the menu.

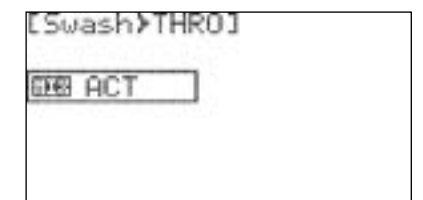

3. Rotate the jog dial to select ACT (activate), then press the jog dial to confirm your selection and activate the swash-throttle menu.

4. Scroll to the function field ("AILE" or "ELEV"). If "AILE" is not the current function, press the jog dial to activate the menu. Otherwise, skip to step 6.

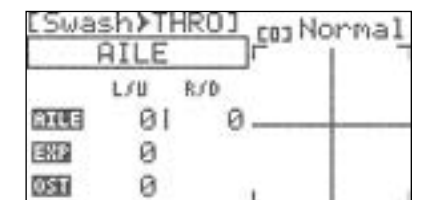

5. Scroll to select "AILE" and press the jog dial to confirm your selection.

6. Scroll to the top row of the value table ("AILE") and press the jog dial to activate the menu.

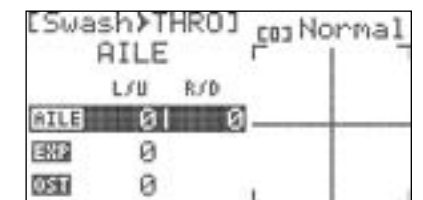

7. By scrolling, you can highlight either the "L/U" (left/up), the "R/D" (right/down) field, or both fields. If you want the swash to throttle mix to be the same for both directions of aileron swash travel (most common), highlight both fields and press the jog dial.

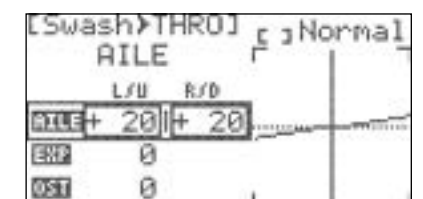

8. Rotate the jog dial to input the desired throttle compensation when a left roll command is given. Press the jog dial to confirm your input.

9. Scroll to highlight the "EXP" field and press the jog dial to activate the selection.

10. Rotate the jog dial to input the desired exponential travel of the throttle servos when reacting to this mix. The setting does not affect exponential travel of the servo when throttle stick inputs are given.



Swash to Throttle Mixing cont.

11. Scroll to highlight the "OST" (Offset) field and press the jog dial to activate the menu.

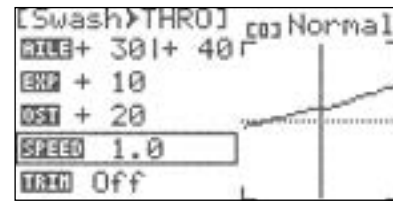

12. Rotate the jog dial to select the desired amount of offset and press the jog dial to enter your selection.

13. Scroll to highlight the "SPEED" field and press the jog dial to activate the menu.



14. Scroll to define the amount of time (0.0 to 10.0 seconds) to transition the settings when this mix is enabled. Press the jog dial to confirm your selection.

15. Scroll to highlight the "TRIM" field and press the jog dial to activate the menu.

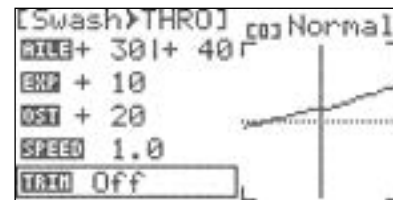

16. Rotate the jog dial to select "ON" or "OFF" and press the jog dial to confirm your selection. When "ON" is selected, the mix reacts to trim adjustments of the ailerons. Otherwise, the mix ignores aileron trim changes.

17. If you wish to adjust the mix for elevator inputs, scroll back up to the function field and press the jog dial to activate the menu. Otherwise, skip to step 20.



18. Rotate the jog dial to select "ELEV" and press the jog dial to confirm your selection.

19. Repeat steps 6-16 to input throttle compensation values for elevator inputs.

20. Scroll to highlight "S/W" and press the jog dial to activate the switch menu.

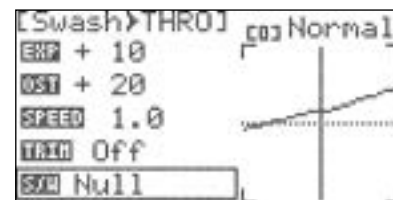

21. Scroll to select a switch to activate the swash-throttle mix. Press the jog dial to confirm your selection.

a. If you choose the "NULL" option, the set mix values will remain active at all times for this model.

b. If you choose a switch:

- The current switch position will be displayed in the top right field of the display as "0", "1", or "2".

- Repeat steps 4-19 as applicable to define a swash-throttle mix for every switch position.

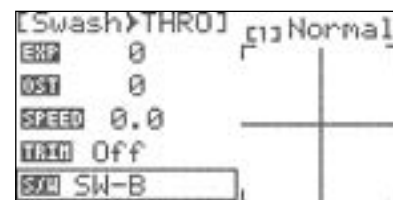

Swash to Throttle Mixing cont.

22. To set up the Swash to Throttle mixing in accordance with a Flight Condition:

- The upper right field of the menu displays which flight condition is currently active and will be programmed.
- Scroll to the Flight Condition field and press the jog dial to activate the menu.
- Choose the desired flight condition and press the jog dial to confirm your selection.



23. Press the Back button to return to the Model Function menu.



Note

If you are using multiple flight conditions, you must define swash-throttle mix values for each flight condition. The top field of the Swash>Thro menu allows you to select the desired flight condition. Alternately, you may select the desired flight condition using the assigned F.Cond switch.

To disable the swash-throttle mix:

1. Scroll to highlight the "MIX" field in the Swash>Thro menu and press the jog dial to activate the menu.
2. Select "INH" (inhibit) and press the jog dial to confirm your selection.
3. Press the Back button to return to the Model Function menu.

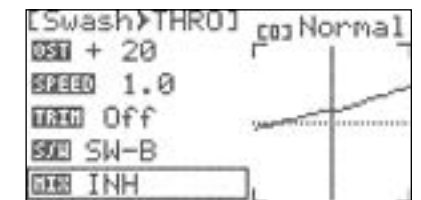

Swash Mix

Swash Plate Adjustment Menu:

Use the swash mix feature to apply a fine adjustment to the swash plate travel. For the very best accuracy, we recommend the use of a swash plate leveling set-up tool.



Tip

As this is a set-up feature, swash mix is one of the few functions that is NOT influenced by flight conditions, idle-up or hold conditions.

Our example will show a 120CCPM head format:

1. From the model menu, scroll to highlight "Swash Mix" and press the jog dial once to enter the sub trim menu.
2. Scroll to the functions (AILE,ELEV,Pitch) to be adjusted and press the jog dial to activate the menu.



Swash Mix cont.

3. Rotate the jog dial clockwise or counter-clockwise to alter the individual collective servos.

4. Press the Back button to return to the Model Function menu.

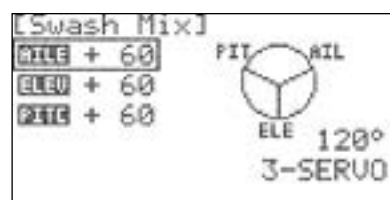

Tip

With all the servos hooked up, and the transmitter and receiver turned on, move the throttle/collective stick up and down. The swash should move up and down with no rotations. Move the aileron stick left and right. The swash should tilt left and right without pitching or rising. Move the elevator stick. The swash should tilt fore and aft with no rotations.

If there are rotations when collective is moved, or the swash moves up and down with aileron or elevator, you need to adjust the settings in the swash menu. If the servos do not all respond in the same direction for collective or opposite directions for aileron and elevator, you will need to reverse one or more of them in the reversing menu (Reverse). It may take a little trial and error using different combinations of normal and reverse rotation to get the servos to respond properly. Don't worry about the direction they respond, just that they all move the same for collective and tilt for aileron and elevator.

Throttle Curve

The Throttle Curve function allows you to modify the normally-linear servo rate movement for throttle by defining five different points along the throttle response curve. It is necessary to manipulate the throttle curve in conjunction with the pitch curve to achieve maximum performance from your helicopter.

To configure a throttle curve:

1. From the Model menu, rotate the jog dial to highlight "T.Curve" and press the jog dial once to enter the activation menu.



2. Press the jog dial again to activate the menu.

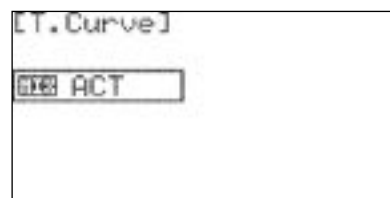

3. Rotate the jog dial to select ACT (activate), then press the jog dial to confirm your selection and activate the throttle curve menu.

4. Scroll to the "1" field and press the jog button to activate the menu.

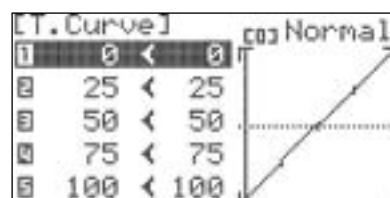

5. Rotate the jog dial to input the desired throttle position at this point on the curve (Throttle stick full down).

Throttle Curve cont.

6. Scroll to the "2" field and press the jog button to activate the menu.

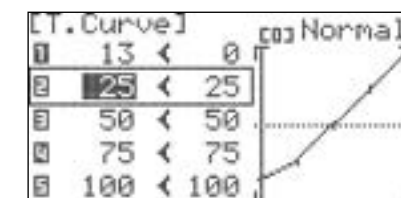

7. The left field represents the throttle servo value and the right field represents the throttle stick position. Select each field independently and use the jog dial to input the desired values for the next point on the throttle curve.

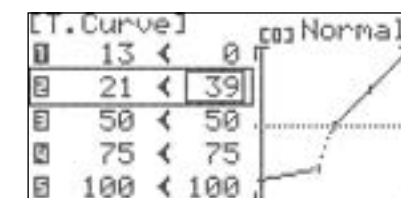

8. Repeat steps 6 and 7 for the remaining three steps on the throttle curve. As values are changed, the on-screen graph displays real-time updates to the throttle curve.

9. Scroll to the "EXP" (exponential) field and press the jog button to activate the menu.

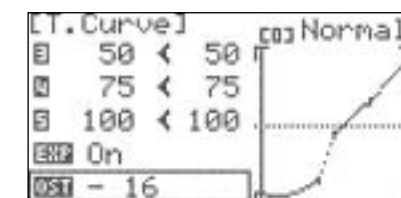

10. Rotate the jog dial to select "OFF" or "ON". When "ON" is selected, the points in the curve are connected with exponential curves. Otherwise, the points are joined linearly. Press the jog dial to confirm your selection.

11. Scroll to highlight the "OST" (Offset) field and press the jog dial to activate the menu.

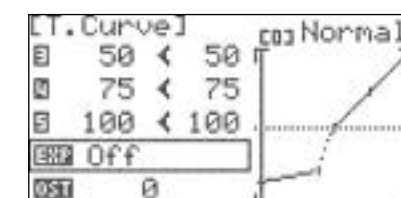

12. Scroll to select the desired amount of offset and press the jog dial to enter your selection.

13. Scroll to highlight "S/W" and press the jog dial to bring up the switch sub-menu.

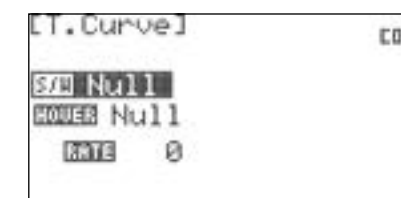

14. Scroll to select a switch to activate the throttle curve. Press the jog dial to confirm your selection.

a. If you choose the "NULL" option, the set throttle curve will remain active at all times for this model.

b. If you choose a switch:

- The current switch position will be displayed in the top right field of the display as "0", "1", or "2".

- Repeat steps 4-8 to define throttle curve for every switch position.

Throttle Curve cont.



Throttle Adjust Feature: Program the LS, RS, LT, or RT switches to work as in-flight adjustment control for throttle curve.

15. Scroll to highlight "HOVER" and press the jog dial to activate the menu.

16. Rotate the jog dial to select a switch to adjust the throttle curve mix during flight. Press the jog dial to confirm your selection.

a. If you choose the "NULL" option, in-flight adjustment is disabled.

b. If you choose a switch:

17. Highlight the "RATE" field and press the jog dial to activate the menu.

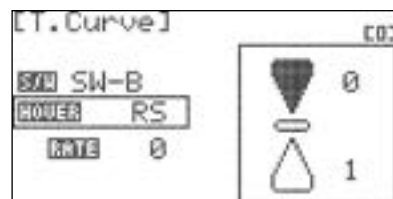

- Rotate the jog dial to input the desired rate that the switch will influence the throttle curve (0-100). Press the jog dial to confirm your selection.

18. The "I/O" (input/output) field is display only. It shows the value of the throttle channel and throttle stick as you actuate the relevant controls. These values are reflected in the graph as well.



If you are using multiple flight conditions, you must define throttle curve for each flight condition. The top field of the T.Curve menu allows you to select the desired flight condition. Alternately, you may select the desired flight condition using the assigned F.Cond switch.

19. To set up Throttle Curves in accordance with a Flight Condition

- The upper right field of the menu displays which flight condition is currently active and will be programmed.
- Scroll to the Flight Condition field and press the jog dial to activate the menu.
- Choose the desired flight condition and press the jog dial to confirm your selection.

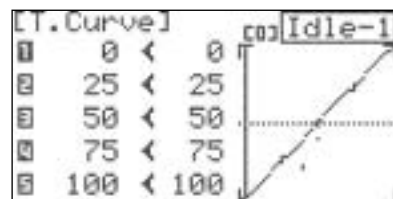

20. Press the back button to return to the model function menu.

To disable the throttle curve:

1. Scroll to highlight the "MIX" field in the throttle curve menu and press the jog dial to activate the menu.

2. Select "INH" (inhibit) and press the jog dial to confirm your selection.

3. Press the Back button to return to the model function menu.

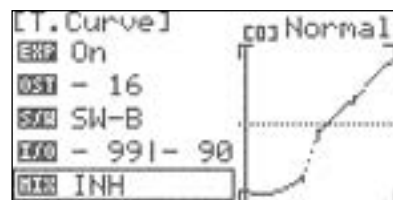

Pitch Curve

The Pitch Curve function allows you to modify the normally-linear servo rate movement for collective pitch by defining five different points along the pitch response curve. It is necessary to manipulate the pitch curve in conjunction with the throttle curve to achieve maximum performance from your helicopter.

To configure a pitch curve:

1. From the Model menu, rotate the jog dial to highlight "P.Curve" and press the jog dial once to enter the activation menu.



2. Press the jog dial again to activate the menu.

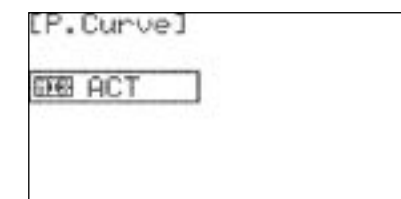

3. Rotate the jog dial to select ACT (activate), then press the jog dial to confirm your selection and activate the pitch curve menu.

4. Scroll to the "1" field and press the jog button to activate the menu.

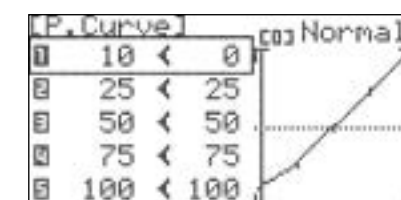

5. Rotate the jog dial to input the desired pitch position at this point on the curve (Throttle stick full down).

6. Scroll to the "2" field and press the jog button to activate the menu.

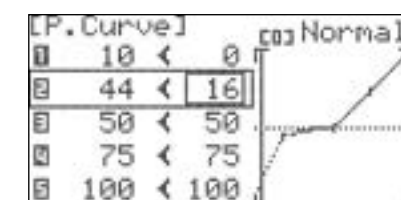

7. The left field represents the pitch servo value and the right field represents the throttle stick position. Select each field independently and use the jog dial to input the desired values for the next point on the pitch curve.

8. Repeat steps 6 and 7 for the remaining three steps on the pitch curve. As values are changed, the on-screen graph displays real-time updates to the pitch curve.

9. Scroll to the "EXP" (exponential) field and press the jog button to activate the menu.

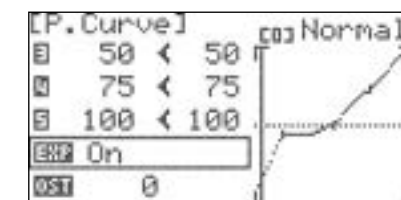

10. Rotate the jog dial to select "OFF" or "ON". When "ON" is selected, the points in the curve are connected with exponential curves. Otherwise, the points are joined linearly. Press the jog dial to confirm your selection.

11. Scroll to highlight the "OST" (Offset) field and press the jog dial to activate the menu.

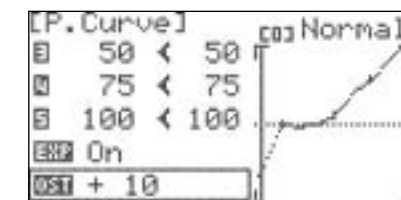

12. Scroll to select the desired amount of offset and press the jog dial to enter your selection.

Pitch Curve cont.

13. Scroll to highlight "S/W" and press the jog dial to bring up the switch sub-menu.

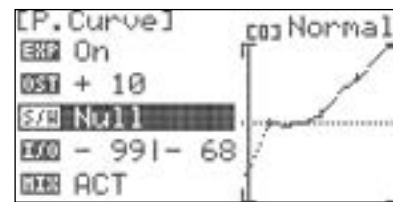

14. Rotate the jog dial to select a switch to activate the pitch curve. Press the jog dial to confirm your selection.

a. If you choose the "NULL" option, the set pitch curve will remain active at all times for this model.

b. If you choose a switch:

- The current switch position will be displayed in the top right field of the display as "0", "1", or "2".

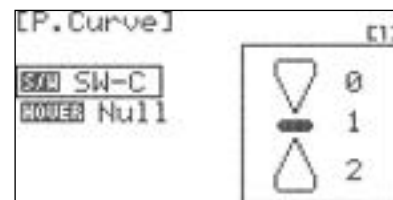

- Repeat steps 4-8 to define pitch curve for every switch position.

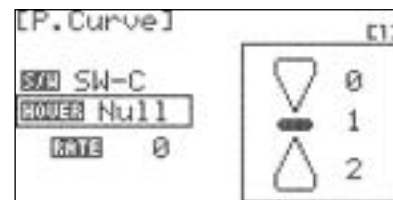

Note **Pitch Adjust Feature:** Program the LS, RS, LT, or RT switches to work as in-flight adjustment control for pitch curve.

15. Scroll to highlight "HOVER" and press the jog dial to activate the menu.

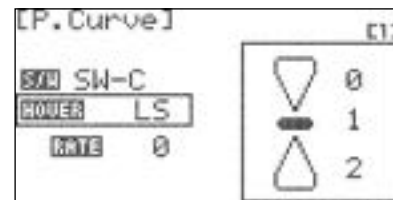

16. Rotate the jog dial to select a switch to adjust the pitch curve mix during flight. Press the jog dial to confirm your selection.

a. If you choose the "NULL" option, in-flight adjustment is disabled.

b. If you choose a switch:

- Highlight the "RATE" field and press the jog dial to activate the menu.

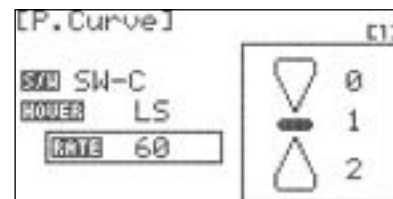

- Rotate the jog dial to input the desired rate that the switch will influence the pitch curve (0-100). Press the jog dial to confirm your selection.

17. The "I/O" (input/output) field is display only. It shows the value of the pitch channel and throttle stick as you actuate the relevant controls. These values are reflected in the graph as well.

Pitch Curve cont.

18. To set up Pitch Curve in accordance with a Flight Condition

- The upper right field of the menu displays which flight condition is currently active and will be programmed.

- Scroll to the Flight Condition field and press the jog dial to activate the menu.

- Choose the desired flight condition and press the jog dial to confirm your selection.

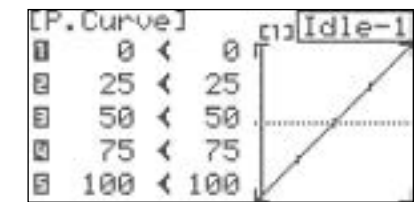

Note If you are using multiple flight conditions, you must define pitch curve for each flight condition. The top field of the P.Curve menu allows you to select the desired flight condition. Alternately, you may select the desired flight condition using the assigned F.Cond switch.

19. Press the back button to return to the model function menu.

To disable the pitch curve:

1. Scroll to highlight the "MIX" field in the pitch curve menu and press the jog dial to activate the menu.

2. Select "INH" (inhibit) and press the jog dial to confirm your selection.

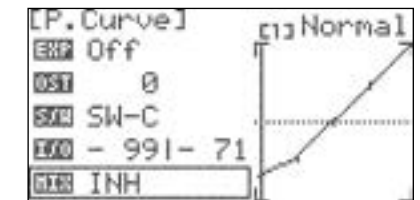

3. Press the Back button to return to the model function menu.

Flight Conditions

The Flash 8 allows you to program up to five flight conditions. This powerful feature lets you define customized trim values and mix settings for different phases of flight.

The flight conditions for helicopter models are:

- 1. Normal
- 2. Idle-1
- 3. Idle-2
- 4. Idle-3
- 5. Hold

The following features support flight condition programming in HELI mode:

- Gyro
- Revolution Mix
- Swash > Throttle Mix
- Throttle Curve
- Pitch Curve

1. From the model menu, rotate the jog dial to highlight "F.COND" and press the jog dial once to enter the flight conditions menu.



Flight Conditions cont.

2. Scroll to the flight condition to be configured and press the jog dial to confirm your selection.

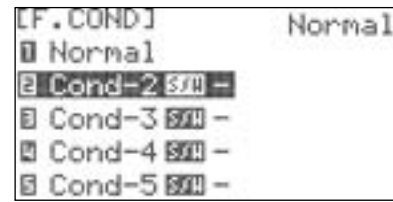

3. Press the jog dial again to activate the switch selection menu (not applicable in "Normal" flight condition).

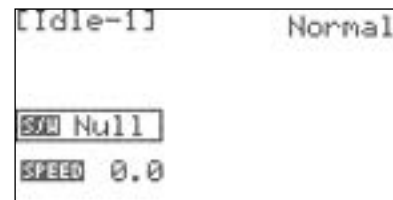

4. Rotate the jog dial to select the switch that you will use to activate this flight condition and press the jog dial to confirm your selection.

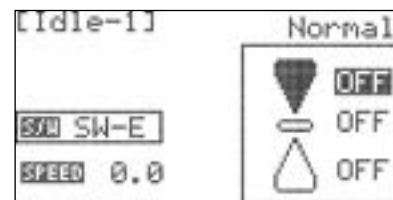

a. If "NULL" is selected, the flight condition will be inactive.

b. If you selected a switch, the switch position menu will appear.
- Scroll to highlight the switch position that you will use to enable the flight condition. Press the jog dial to confirm your selection.

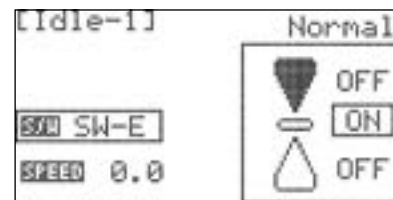

- Rotate the jog dial to select "ON" and press the jog dial to confirm your selection. If you toggle the selected switch, the field in the top right corner of the screen will indicate which flight condition is active.

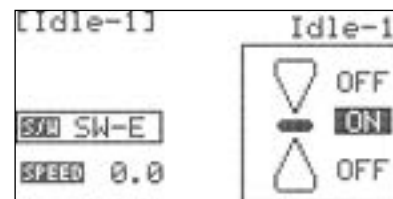

- Press the back button twice to return to the flight conditions menu.



Note

If the more than one flight condition is concurrently enabled, the condition with the highest number (per the table shown above) will be active. The field just below the model icon on the Home screen indicates the active flight condition.

5. Scroll to highlight the "SPEED" field and press the jog dial to activate the menu.

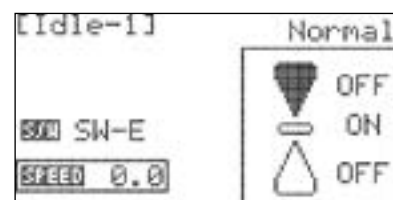

Flight Conditions cont.

6. Rotate the jog dial to define the amount of time (0.0 to 10.0 seconds) to transition the settings when this flight condition is enabled. Press the jog dial to confirm your selection. This feature can be utilized to prevent sudden control surface movements when switching between flight conditions.

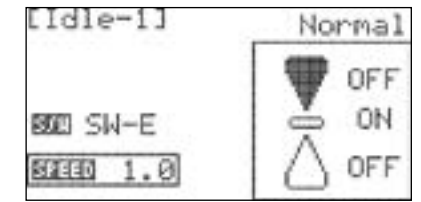

7. Press the back button to return to the flight conditions menu and repeat steps 2-6 to define further flight conditions.

8. Press the back button twice to return to the model function menu.

Swash Ring

The Swash Ring Mix limits the travel of the servos attached to the helicopter swash plate. This can be used to help prevent binding of the control system when using large control movements for aerobatics.

To configure swash ring:

1. From the model menu, rotate the jog dial to highlight "Swash Ring" and press the jog dial once to enter the activation menu.



2. Press the jog dial again to activate the menu.

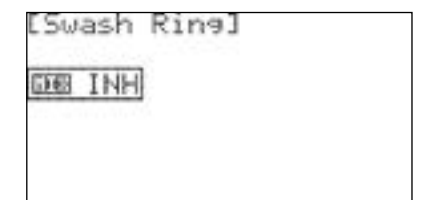

3. Rotate the jog dial to select ACT (activate), then press the jog dial to confirm your selection and activate the Swash Ring mix.

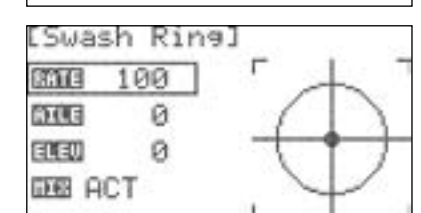

4. Press the jog dial to enter the "RATE" menu.

5. Rotate the jog dial to set the value that you want limit swash (aileron and elevator) channels. Press the jog dial to confirm your selection.

6. The "AILE" and "ELEV" fields are for display only. They show the value of the aileron and elevator channels as you actuate the relevant controls. These values are reflected in the graph as well.

7. Press the back button to return to the model function menu.

To disable the swash ring:

1. Scroll to highlight the "MIX" field in the pitch curve menu and press the jog dial to activate the menu.

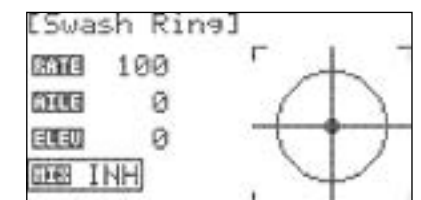

2. Select "INH" (inhibit) and press the jog dial to confirm your selection.

3. Press the Back button to return to the model function menu.

Throttle Lock

The Flash 8 features a “throttle lock” function that can be activated when the transmitter is transmitting a signal. We encourage you to use the throttle lock feature as a safety precaution against “accidental throttle application”.

1. To turn the throttle lock on, highlight “THRO Lock” from the model setup menu and press the jog dial to enter the setup screen.



2. To select which switch will be used for the throttle lock press the jog dial to enter the switch selection menu.

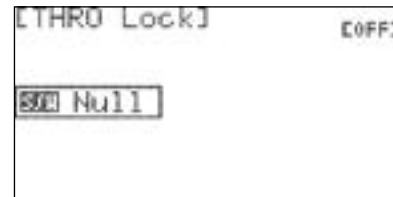

3. Rotate the jog dial to select a switch used to activate the throttle lock function. Press the jog dial to confirm your selection.

a. If you choose the “NULL” option, the function will remain inactive at all times for this model.

b. If you choose a switch:

- The switch position menu will appear. Scroll to highlight the switch position that you will use to enable the function. Press the jog dial to confirm your selection.

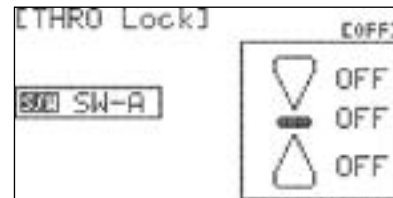

- Scroll to select “ON” and press the jog dial to confirm your selection. If you toggle the selected switch, the field in the top right corner of the screen will indicate when the mix is active.

4. Press the back button twice to return to the Model menu.

Using the Telemetry System

SECTION 7

When paired with an Optima 7, Optima 9, or Optima SL receiver, the Flash 8 is fully compatible with Hitec’s suite of telemetry sensors. The ability to receive important data from the model is critical to preventing crashes due to dead batteries, an empty fuel tank, or overheated components. Additionally, telemetry data is priceless when fine-tuning your model to reach the peak of its performance capability. With each tweak to your model, you can generate empirical data to understand the performance effects of the change.

All Optima receivers will report the receiver battery voltage without the need for an add-on sensor. All other types of data require a sensor as well as a sensor station. A single sensor station can accommodate numerous and varied sensors. The sensor station and sensors that you choose are dependent on the model’s power system and/or the type of data that you wish to collect. Visit Hitec’s website (www.hitecrd.com) for details on the sensor stations and sensors that are available.

In the Flash 8 Sensor menu, you will find the following telemetry parameters:

GPS: Global Positioning System device capable of determining precise location and speed data.

RPM: Provides RPM data for electric, glow or gas motors.

TEMP: Provides temperature data from multiple sensors.

Battery: Provides power system parameters for electric aircraft and receiver voltage data for all types of models.

Servo: Provides current draw data for servos.

Advanced: Provides airspeed and altitude rate-of-change data.

Working with the Sensor Menu

1. Verify that the model is linked to an Optima receiver.

2. Verify that the sensors and sensor station are connected per their respective manuals (only valid for Optima 7, Optima 9, and Optima SL).

3. Turn on the transmitter by pressing the power button momentarily. Do NOT power on the airplane.

4. Turn on the receiver’s power source.

5. To access the transmitter’s SENSOR menu, simultaneously press the back button and jog dial.

6. Scroll to “SENSOR” and press the jog dial to activate the menu.



GPS

The GPS screen displays real-time latitude, longitude, altitude and speed data.

Required Sensor: HTS-GPS GPS Sensor

1. From the sensor menu, rotate the jog dial to highlight "GPS" and press the jog dial once to enter the GPS menu.

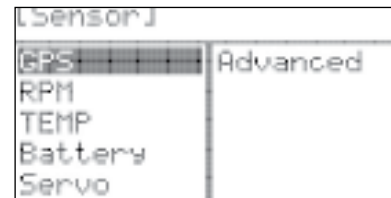

2. Scroll to the "UNIT" field and press the jog dial to confirm your selection.

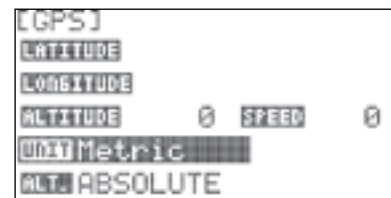

3. Scroll to select "Metric" (meters, meters per second) or "Imperial" (feet, feet per second) units and press the jog dial to confirm your selection.

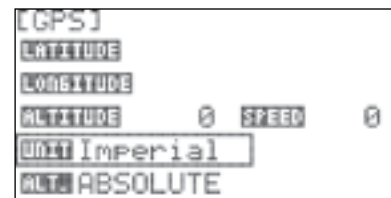

4. Scroll to the "ALT" field and press the jog dial to confirm your selection.

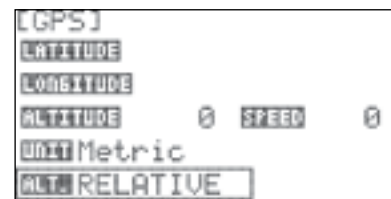

5. Scroll to select "RELATIVE" or "ABSOLUTE". Relative mode is the most commonly used option. In this setting, altitude is displayed as the model's height above the launch altitude. If absolute is selected, the altitude will be displayed as the model's height above sea level.

6. Press the back button to return to the sensor menu.

RPM

The RPM screen displays RPM data for electric, glow, or gas motors in an airplane or helicopter. Data from two sensors can be displayed simultaneously.

Required Sensor: HTS-MRPM Magnetic RPM Sensor or HTS-ORPM Optical RPM Sensor

1. From the sensor menu, rotate the jog dial to highlight "RPM" and press the jog dial once to enter the RPM menu.

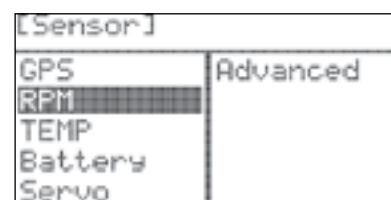

RPM cont.

2. Scroll to the top "UNIT" field and press the jog dial to confirm your selection.



3. Scroll to select "Prop-M" is using the magnetic RPM sensor. If using an optical sensor, select "Prop-2", "Prop-3" or "Prop-4". The numeral indicates the number of blades on your propeller. Press the jog dial to confirm your selection.



4. If you are using a second RPM sensor, repeat steps 2 and 3 on the lower "UNIT" field.

5. Press the back button to return to the sensor menu.

Temperature

The TEMP screen displays temperature readings from as many as four separate temperature sensors. An additional field (H.TEM) displays the highest temperature recorded during the flight.

Required Sensor: HTS-TEMP Temperature Sensor or HTS-eTEMP Engine Temperature Sensor

1. From the sensor menu, rotate the jog dial to highlight "TEMP" and press the jog dial once to enter the temperature menu.

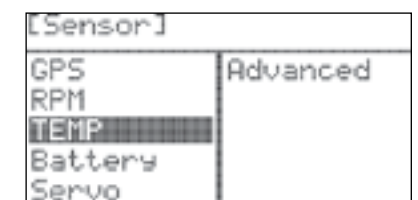

2. Press the jog dial again to activate the "UNIT" field.

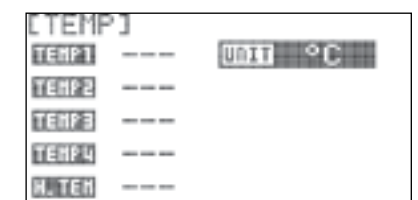

3. Scroll to select "°F" or "°C". Choose °F to receive temperature in degrees Fahrenheit, and °C for degrees Celsius. Press the jog dial to confirm your selection.

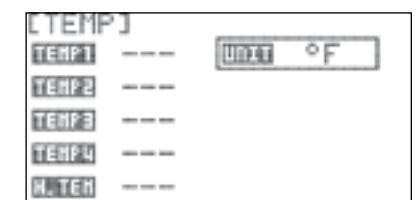

4. Press the back button to return to the sensor menu.

Battery

The Battery screen displays the voltage of the receiver battery (no sensor is required for this data). Additionally, this screen displays flight pack voltage, motor current, and motor wattage for electric-powered models.

Required Sensor: HTS-C50 50-Amp Current Sensor or HTS-C200 200-Amp Current Sensor



Receiver battery voltage is also displayed on the lower right corner of the Flash 8 home screen.

1. From the sensor menu, rotate the jog dial to highlight "BATTERY" and press the jog dial once to enter the battery menu.

2. Scroll to select the "RX. BATT" and press the jog dial to activate the menu.

3. Rotate the jog dial to check the Max. & Min. value and press the back button to reset.

4. Scroll to the "L.WAR" and press the jog dial. Rotate the jog dial to select the low voltage alarm setting, press the jog dial to confirm your selection.

5. Scroll to the "ALARM" and press the jog dial to confirm your selection. Rotate the jog dial to select either "ON" or "OFF". Press the back button to return to the battery menu.

6. Scroll to select the "CURRENT" and press the jog dial to activate the menu.

7. Rotate the jog dial to select the "C50" or "C200" and press the jog dial to confirm your selection.

8. Press the back button to return to the sensor menu.

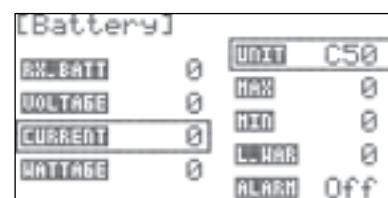
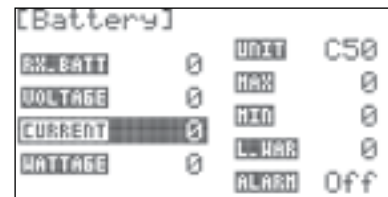
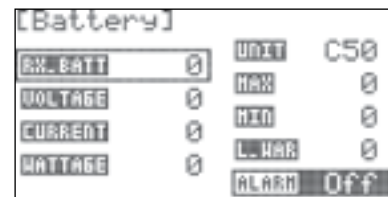
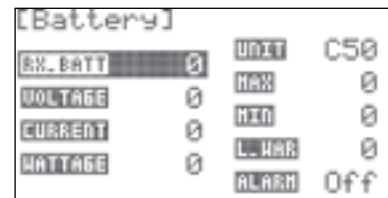
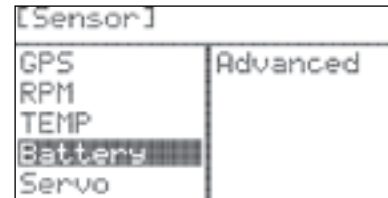

Servo

The Servo screen displays the current draw for each servo attached to the outputs of the Servo Manager sensor.



If multiple servos are attached to a single sensor output using a Y-harness, the display will show the total amperage for all servos connected to that output.

Required Sensor: HTS-SM Servo Manager Sensor (compatible only with the HTS-SS Advanced Sensor Station)

1. From the sensor menu, rotate the jog dial to highlight "Servo" and press the jog dial once to enter the Servo screen.

2. Press the back button to return to the sensor menu.

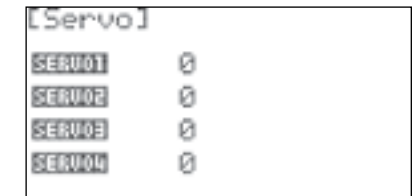

Advanced

The Advanced screen displays airspeed data collected from Hitec's dedicated airspeed sensor (not GPS), as well as rate-of-climb data collected by a variometer.

Required Sensor: HTS-AS Air Speed Sensor and HTS-VM Variometer Sensor (both sensors are compatible only with the HTS-SS Advanced Sensor Station)

1. From the sensor menu, rotate the jog dial to highlight "Advanced" and press the jog dial once to enter the advanced menu.

2. Scroll to the "CLIMB SOUND" field and press the jog dial to confirm your selection.

3. Scroll to select "ON" if you would like the transmitter to emit a tone when the model is gaining altitude. Otherwise, select "OFF". Press the jog dial to confirm your selection.

4. Scroll to the "SINK SOUND" field and press the jog dial to confirm your selection.

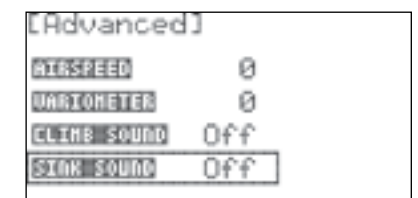
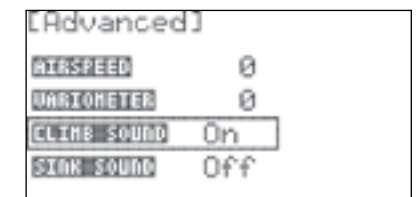
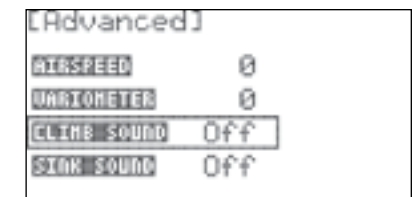
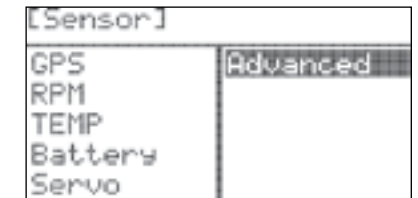

Advanced cont.

5. Scroll to select "ON" if you would like the transmitter to emit a tone when the model is losing altitude. Otherwise, select "OFF". Press the jog dial to confirm your selection.

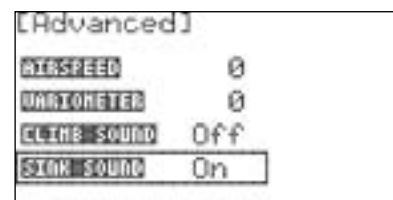

6. Press the back button to return to the sensor menu.

Viewing Telemetry Data

While the various sensor screens on the Flash 8 display can be used to view real-time telemetry data, it is often inconvenient or unsafe to use them while flying. In these cases, there are interface options which provide convenient and safe solutions.

The Flash 8 is compatible with the HPP-22 (wired) and HTS-NAVI (wireless) PC Interface modules. When using either module in conjunction with the HPP-22 software, the telemetry data can be viewed in a large dashboard-type format that is highly customizable. Additionally, these interface modules permit logging of telemetry data for post-flight playback and analysis.



You may also utilize the HTS-Voice Telemetry Voice Announcing System. This speaker system attaches to the transmitter handle and provides periodic voice announcements of selected telemetry data during your flight. You can configure the data that is reported as well as the frequency of the announcements. The module is also equipped with a headphone jack. Using ear bud-type speakers in this jack is a practical method to hear the voice announcements at noisy flying sites and/or avoid disturbing nearby pilots.

Stick Length Adjustment

Hands come in all sizes so, to accommodate everyone, we use a two piece stick "top" that can be adjusted to fit a wide variety of users.

Separate the top from the bottom piece and adjust the top piece to the length required. Screw the bottom up against the top piece to "jam" lock everything into position.

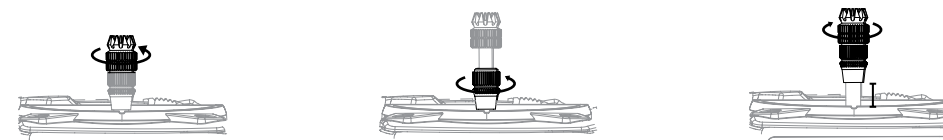

Stick Lever Tension Adjustment / Mode Change

Stick Lever Tension Adjustment

You may adjust the stick tension of your sticks to provide the "feel" that you like for flying. To start, remove the rubber grips on the back of the radio. After removing the rubber grip, use a 1.5mm allen wrench to adjust the tension. Turning the screw clockwise will increase the tension, while turning it counterclockwise will decrease the tension.



Please use 1.5mm hex key for gimbals' tension adjustment and mode changes.

Change to 'Mode 1' Configuration

All Flash 8 systems sold in the US are in 'Mode 2' format. However, you can change the Flash 8 to 'Mode 1' format. There is a menu choice for this option in the Initial Set-Up function menu described on Page 26. After selecting 'Mode 1' in the Initial Set-Up Menu, you must do the following hardware set-up in order to change the transmitter:

1. Remove the two rubber grips and two covers on the back of the radio.
2. Using a phillips screwdriver adjust the screws on the throttle Ratchet.
3. Tighten until you do not feel the tension of the spring.
4. Using a 1.5 mm hex driver loosen the screws in order to create enough tension on the spring and adjust the neutrality of the stick.
5. Return the rubber grips and covers back to their original locations.

