

**2.4GHz** ADAPTIVE  
Telemetric **FREQUENCY HOPPING**  
**AFHSS** SPREAD SPECTRUM

**AURORA 9X**

Instruction Manual

**Evolutionary Genius**

9 CHANNEL 2.4GHz AIRCRAFT COMPUTER RADIO SYSTEM

# AURORA 9X

Instruction Manual ver1.2



**HITEC**



**4096**  
Resolution

**SLT**  
SECURE LINK TECHNOLOGY

Fly any SLT protocol Tx-Ready models with the Aurora 9X. No additional modules or equipment required, just change the protocol in the program and you're ready to fly. For more information on Tx-Ready Models visit [Tx-Ready.com](http://Tx-Ready.com)

**HITEC**

### Introduction

Thank you for purchasing the Aurora 9X radio by Hitec. Designed for all popular aircraft types, the Aurora 9X delivers lightning fast response with its 7ms frame rate and 4096 step resolution.

You can trust Hitec's bi-directional, AFHSS (Advanced Frequency Hopping Spread Spectrum) 2.4GHz technology to guide your sailplane, gas, glow or electric power plane or heli to a safe landing every flight.

We are sure you will find the Aurora 9X one of the easiest radios to program. Please review this entire manual to learn how to safely use your new radio. It's a good idea to keep the manual with your Aurora 9X at all times.

### Content Disclaimer

Please note that Hitec reserves the right to make production changes during the life of our product lines that may impact the information in this manual.

For the most up-to-date information on this and any other Hitec product, visit our web site at [www.hitecrcd.com](http://www.hitecrcd.com).

#### Hitec RCD Inc. R/C Controller

**Model No :** AURORA 9X

**POWER :** 1. Power supply from the AC/DC Adapter  
input - AC 100 V~240V: 50Hz/60Hz  
Output - TX : DC 7.2V : 150mA  
2. Rechargeable Battery : NiMH, Ni-Cd

**Serial No :** NONE

This device complies with part 15 of the FCC Rules.  
Operation is subject to the following two conditions:  
(1) This device may not cause harmful interference, and  
(2) This device must accept any interference received,  
including interference that may cause undesired operation.

Manufacturer : HITEC RCD PHILIPPINES, INC  
Made in Philippines

**Table of Contents**

**Section One**

**Introduction**

- 2---- **Introduction**
- 3---- **Table of Contents**
- 6---- **Steps for Successfully Programming the Aurora 9X**
  - Using this Manual
  - Quick Set-up Guides
  - Aurora 9X Software Architecture Explained
- 7---- **What's New?**
- 7---- **Aurora 9X Transmitter Accessories**
- 8---- **Product Support**
- 9---- **System Component Specifications**
- 9---- **Glossary of Terms**
- 10---- **Icon Identification**
- 11---- **Safety Information**
  - Warnings
- 13---- **Transmitter Battery Information**
- 14---- **Hitec 2.4GHz System**
  - Maxima Series Receiver Features
  - Optima and Minima Series Receiver Features
  - Binding Maxima Receivers
  - Binding Optima and Minima Receiver
  - Failsafe and Hold Setup
  - Telemetry System
  - Range Check Function
  - Scan Mode
  - SLT Technology
- 27---- **Aurora 9X Transmitter Controls**
- 30---- **Touch Screen Lock**
- 31---- **The First Screen**
  - Multi-I/O port
- 33---- **Home Screen Menu**

**Section Two**

**Quick Start Guide to setting up a simple powered airplane or glider**

- 34---- **System Programming Menu**
- 38---- **Model Programming Menu**

**Section Three**

**Quick Start Guide to setting up a heli**

- 42---- **System Programming Menu**
- 45---- **Model Programming Menu**

**Section Four****System Menu**

51----	<b>MDL Select</b>	Create a new model Select an existing model Copy one model's data into a fresh model memory slot Reset the model memory to factory default settings Rename a model
53----	<b>MDL Type</b>	Model type menu, ACRO, GLID or HELI
58----	<b>Timer</b>	Menu for Timer 1, 2 and the Integral timer
61----	<b>Channel</b>	Model control channel assignment menu
62----	<b>TrimStep</b>	Size adjustment menu for the trim steps
63----	<b>Sensor</b>	Telemetry menu appearing while in 2.4GHz mode only.
65----	<b>Trainer</b>	Trainer option menu
67----	<b>Spectra Control</b>	
68----	<b>Systems Management</b>	
70----	<b>Mode</b>	
71----	<b>Hardware Reverse</b>	
72----	<b>Info</b>	Transmitter ID information

**Section Five****Model Menu and more...****Special Hints**

75----	<b>Additional Menus, Custom and Adjust Features</b>
75----	<b>Adjustment Menu</b>

**The Switch Selection Process**

76----	<b>Selecting a switch</b>
79----	<b>Adjust function switch set-up</b>
80----	<b>Additional camber and launch mode adjust function menu (GLID)</b>
81----	<b>Helicopter throttle and pitch curve adjust functions, hover trim and more</b>
82----	<b>Trim link activation</b>
83----	<b>Cut position set-up</b>
84----	<b>Launch cut switch set-up</b>

**Common Model Functions to ACRO, GLID and HELI**

85----	<b>EPA</b>	End Point Adjustment
86----	<b>D/R &amp; EXP</b>	Dual Rates and Exponential (expo) rates
87----	<b>Sub-Trim</b>	Servo Sub-trim adjustment
87----	<b>Reverse</b>	Servo reversing function
88----	<b>S. Speed</b>	Servo Speed feature
88----	<b>Monitor</b>	Active model control monitor
89----	<b>T. Limit</b>	Travel Limit
90----	<b>P. Mixs</b>	Programmable Mixing
92----	<b>Gyro</b>	Gyro on/off and Sensitivity Adjustment



**Section Six**

**Model Menu**

**Common Model Functions to ACRO and GLID**

94----	<b>FLT.COND</b>	Flight Conditions	
101----	<b>Spoiler</b>		
102----	<b>SPO- ELE</b>	Spoiler to Elevator mix	
104----	<b>AIL-RUD</b>	Aileron to Rudder mix	
105----	<b>ELE-CAM</b>	Elevator to Camber mix	
106----	<b>RUD-AIL</b>	Rudder to Aileron mix	
107----	<b>AIL DIFF</b>	Aileron Differential feature	
108----	<b>AIL- FLP</b>	Aileron to Flap mix	
109----	<b>CAMBMIX</b>	Wing trailing edge mix	
110----	<b>FLP CON</b>	Flap control mix	
111----	<b>FLAPTRIM</b>	Flap Trim Mix	
112----	<b>V.Tail</b>	V-Tail mix feature	
113----	<b>AILEVATR</b>	Split elevator and aileron inclusion mix	
114----	<b>Elevon</b>	Elevon or flying wing mix	
115----	<b>Thro.Cut</b>	Throttle cut position	<b>ACRO only</b>
116----	<b>T.Curve</b>	Throttle curve	<b>ACRO only</b>
117----	<b>IdleDown</b>	Throttle Idle down position	<b>ACRO only</b>
118----	<b>B-fly</b>	Butterfly or "Crow" mix	<b>GLID only</b>
119----	<b>SnapRoll</b>	Snap roll function	<b>ACRO only</b>
122----	<b>Knife Edge</b>		
123----	<b>Motor</b>	Glider motor control feature	<b>GLID only</b>
124----	<b>Launch</b>	Launch mix	<b>GLID only</b>
125----	<b>Offset</b>		

**Section Seven**

**Model Menu**

**HELI Specific Functions**

128----	<b>FLT.COND</b>	Idle-up and hold / Flight Conditions
130----	<b>P. &amp; T. Curve</b>	Pitch curve & Throttle curve adjustment
132----	<b>Needle</b>	Carburetor needle function
133----	<b>SWH-THR</b>	Swash plate movement to throttle mix
134----	<b>RUD-THR</b>	Tail rotor to throttle mix
135----	<b>T. HOLD</b>	Throttle hold function
136----	<b>SwashMix</b>	Swash plate fine tuning menu
139----	<b>REVO Mix</b>	Revolution mix
140----	<b>Gyro</b>	Gyro functions
141----	<b>Governor</b>	RPM governor adjustment

### Steps for Successfully Programming the Aurora 9X

#### Using the Manual

This manual is a valuable resource detailing the programming and operation methods of the Aurora 9X.

#### The Aurora 9X manual is divided into seven distinct sections:

- Section One.** Introductory material that is mandatory reading.  
This is where you will learn detailed information that will be invaluable to the successful programming of the Aurora 9X.
- Section Two.** Airplane/Glider quick start guide.
- Section Three.** Heli Quick start guide.
- Section Four.** System menu programming common to all ACRO, GLID and HELI models.
- Section Five.** Model Menu programming common to ACRO, GLID and Heli models.  
Compose CUSTOM menu and assign to all switches.
- Section Six.** Model menu programming for ACRO and GLID models.
- Section Seven.** Model menu programming specific to HELI models.

#### Warning, Caution, Note and Tip Boxes

Throughout the manual, you will see important information inside a labeled box. Take note of this important information.



Warning



Caution



Tip



Note

- Warning:** This icon alerts you to warnings that relate to your safety and to help ward against damage to the Aurora 9X.
- Caution:** This icon indicates that careful attention must be paid.
- Tip :** This icon points out valuable technical information.
- Note :** This icon indicates that further information is available.

#### Quick Set-up Guides

We recommend that you read the introductory information in section one, then proceed to one of the quick start guides and start programming. After following along with the quick start guide you will have a feel for the way the Aurora 9X programming is laid out. We encourage you to set up a few aircraft before you fly the Aurora 9X. It will be time well spent and help acquaint you with the programming process.

#### Aurora 9X Software Architecture Explained

The Aurora 9X features open software architecture. This flexibility allows you to assign each function to almost any switch, slider, gimbal stick or button. To ease your way through the programming, many of the traditional channel choices and control functions default to familiar settings. By the time you graduate to programming more complicated models with their increasingly sophisticated setups, you will be familiar with programming your Aurora 9X.

As you add more functions and choices to a model program, you may be called upon to tell the Aurora 9X what switch you would like to activate these additional features. Options such as retracts, gyros, dual and exponential rates, fight conditions and mixing functions may be assigned to your preferred switch, slider, button or stick position.

The Aurora 9X is a powerful computer and as with any computer, the only way to really become proficient with its software is to use it.

At Hitec, we encourage you to invest some time with your 9X, setting up various airframes to familiarize yourself with the software and programming architecture before you head to the field to fly. The programming-flow guides you through the setup process of each new model. You will find with a little practice, you will soon master the Aurora 9X's capabilities.

## What's New?

Based on our successful Aurora 9, the Aurora 9X sports the following new features.

- 1. Three different 2.4GHz signal transmission technologies** - The Aurora 9X can transmit using three different 2.4GHz signals. Our AFHSS (bi-direction), AFHSS (single-direction) and SLT (single- direction) signal technologies. These 3 signals are compatible with our OPTIMA, MINIMA and MAXIMA receivers.
- 2. Integrated Module** - The new built-in module helps provide a stable and faster system operation.
- 3. Built-in SLT (Secure Link Technology) system** - The Aurora 9X can control any TX-Ready model airplane using the popular SLT protocol.
- 4. New Dual Processor** - Our new dual processor in the Aurora 9X provides improved interface speeds of 7ms, the fastest response time on the market.
- 5. 4096 Resolution** - At 4 times the resolution of the Aurora 9, our 4096 step resolution gives you more precise and crisp servo movement.
- 6. Touch Screen programming** - The large 5.1 inch wide touch screen uses updated firmware and the dual processor delivers faster screen refresh rates while the new "Power Miser" feature results in a longer operating period.
- 7. Vibration Motor** - We adapted an internal vibration motor into the Aurora 9X so you can choose to feel the transmitters programming cues and warnings.
- 8. Mix Curves** - Most of the mixes now have the option to be fine-tuned with 7 point curves.

## Aurora Transmitter Accessories

There are a several accessories available for your Aurora transmitter. Check the Hitec website for information as more accessories are added to the Aurora and Hitec 2.4GHz system product lines.

### Transmitter Battery Pack

6 cell, 2000mAh NiMH Pack. Part # 54128

### HPP-22 PC Interface

Used to interface the Aurora 9X with a PC, it will offer a variety of functions including updating the Aurora with future software versions, Part # 44470

### Trainer Cord

The Hitec trainer cord system can be used to link two Hitec transmitters together for flight training purposes. Part number #58321 includes the complete trainer cord assembly.

### Transmitter Weight Balancer

The transmitter weight balancer is designed to use with the neck strap and helps the user be in the optimum position to use Aurora 9X. Part #55843 : Red

### Transmitter Aluminum Case

To protect your Aurora 9X, check out our high impact aluminum case. It holds not just your transmitter, but also keeps other accessories together. Part #55445

### Control Knob

The control knob allows you to customize the height of the Aurora 9X's stick ends to your preferences.. Part #55838: Silver, #55839: Red

## Product Support

### Aurora 9X Programming Support

While every attempt was made by the Aurora 9X's developers to make the software interface easy and logical, most users will require programming help at some point. There are several "get help" options available to you.

### Hitec Customer Service

Help is available from the Hitec office through phone support and e-mail inquiries. The U.S. office is generally open Monday thru Friday, AM 8:00 to PM 4:30 PST. These hours and days may vary by season. Every attempt is made to answer every incoming service call. Should you get voice mail, leave your name and number and a staff member will return your call.

### Hitec Web Site

Make plans to visit the Hitec web site on a regular basis, [www.hitecrd.com](http://www.hitecrd.com) or [www.hitecaurora.com](http://www.hitecaurora.com). It is full of specs and other information about the entire Hitec product line, and our FAQ pages will eventually hold valuable information about the Aurora.

### The On-Line Community

One of the benefits of the extensive R/C online community is the vast wealth of archived knowledge available. Hitec sponsors forums on most of the popular R/C web sites where a Hitec staff member or representative tries to answer all manner of product related questions. Bringing together strangers with common interests is proving to be one of the greatest gifts of the internet. If past history is any guide to the future, we are certain forums will be started about the Aurora 9X and several are sure to stand out as valuable archives of information.

### Warranty and Non-Warranty Service

All Hitec products carry a two year from date-of-purchase warranty against manufacturer's defects. Our trained and professional service representative will determine if the item will be repaired or replaced.

To provide all the necessary information we need to administer your repair, visit our web site at, [www.hitecrd.com](http://www.hitecrd.com) and download the repair form, fill it out and send in your item for repair.

### Hitec Service

12115 Paine St.  
Poway CA 92064

1-858-748-6948

E-mail, [service@hitecrd.com](mailto:service@hitecrd.com)

## System Component Specifications

### Aurora 9X Transmitter

**Modulation : Built in 2.4GHz module**

OPTIMA (AFHSS Bi-direction) : Bi-direction communication capable OPTIMA series receivers can be used.

MINIMA (AFHSS Single-direction): Single-direction communication capable MINIMA series receivers can be used.

MAXIMA (AFHSS Single-direction) : High response (7ms) Single-direction communication capable MAXIMA series receivers can be used.

**Power Supply :** 7.2V Supplied NiMH Battery

**Current Drain :** 300 mA

### Optima 2.4GHz Series Receiver

Receiver Model	Size	Weight	Stock Number
- Optima 6	1.81 x 0.82 x 0.47in (46.1 x 21.3 x 12.1mm)	0.52oz (15g)	28410
- Optima 7	2.20 x 0.79 x 0.43in (56.9 x 20.8 x 11.6mm)	0.60oz (17g)	28414
- Optima 9	1.85 x 1.14 x 0.59in (47.7 x 29.1 x 15.5mm)	0.77oz (22g)	28425

**Operating Voltage :** 4.8~7.4V from a receiver battery, or a BEC (Battery Eliminate Circuit) power from Electronic Speed Controller.  
4.8~35.0V using SPC function

**Current Drain :** 190mA

### Maxima 2.4GHz Series Receiver

Receiver Model	Size	Weight	Stock Number
- Maxima 6	1.29 x 0.81 x 0.42in (33 x 20.08 x 10.7mm)	0.22oz (6.4g)	27524
- Maxima 9	1.45 x 0.97 x 0.57in (37 x 24.4 x 14.6mm)	0.28oz (8.1g)	27525

**Operating Voltage :** 3.7~9.0V from a receiver battery power from Electronic Speed Controller.

**Current Drain :** 30mA

### Minima 2.4GHz Series Receiver

Receiver Model	Size	Weight	Stock Number
- Minima 6 T	1.19 x 0.81 x 0.27in (30.4 x 20.8 x 7.11mm)	0.22oz (6.5g)	26610
- Minima 6 E	1.24 x 0.81 x 0.42in (31.7 x 20.8 x 10.9mm)	0.28oz (8.1g)	26612

**Operating Voltage :** 3.7~9.0V from a receiver battery power from Electronic Speed Controller.

**Current Drain :** 30mA

## Glossary of Terms

<b>AFHSS 2.4GHz Signal</b>	Hitec 2.4GHz R/C signal protocol. Adaptive Frequency Hopping Spread Spectrum.
<b>Telemetry</b>	Data signal from the model, transmitted to the transmitter.
<b>Rangecheck</b>	A ground check of the signal strength between the Tx and Rx. Done before flying.
<b>Scanning</b>	Hitec 2.4GHz transmission signal choice.
<b>Link(ID Setting)</b>	Link or "binding" a 2.4GHz receiver to its master transmitter.
<b>HPP-22 PC Interface</b>	Aurora PC interface accessory.
<b>Multi-I/O Format</b>	File sharing, trainer and PC interface mode.
<b>OST</b>	Offset curve feature
<b>EXP</b>	Exponential rate curve feature
<b>Delay</b>	Function initiation speed adjustment

**Icon Identification****Icon Identification**

<b>MODEL</b>	The model menu contains the model programming for the active model.
<b>ACRO</b>	Menu for fixed wing, glow, gas and some electric models.
<b>GLID</b>	Menu for gliders and some electric models.
<b>HELI</b>	Menu for rotary wing aircraft.
<b>EXIT DOOR</b>	Appears in the upper right corner, the "go back" icon.
<b>FOLDER</b>	The custom menu. Often used, or "quick access" feature folder.
<b>WRENCH</b>	The system menu contains model set-up and transmitter feature menus.
<b>ADJUST</b>	The adjustment menu contains the adjustment features for quick access.
<b>AILE</b>	Aileron for fixed wing menus and the "roll" swash input for helis.
<b>ELEV</b>	Elevator for fixed wing menus and the "pitch" swash input for helis.
<b>RUDD</b>	Rudder for fixed wing menus and the "yaw", or tail rotor input for helis.
<b>1/2, 1/3, 1/6 FRACTIONS</b>	Indicates the number of pages in the menu. Press to access the next page.
<b>+ RST -</b>	Often used Aurora menu value input icons. Value adjustment icon + /-, RST: Reset
<b>Arrow</b>	Press to cycle through menu options.
<b>C</b>	Combination icon. Flight mode option, "groups" the flight mode values.
<b>S</b>	Separate icon. Flight mode option, "separates" the flight mode value.
<b>INH</b>	Inhibit is used to "turn off" a function.
<b>SEL</b>	Select is used to "select" a feature of the displayed menu.
<b>ACT</b>	Active, "turns on" a function.
<b>NULL</b>	"No switch" selected, the function or feature will be "on" all the time.
<b>AUX</b>	An "open" channel, without a control assigned to it.
<b>J1</b>	Right gimbal, up and down control.
<b>J2</b>	Right gimbal, side to side control
<b>J3</b>	Left gimbal, up and down control.
<b>J4</b>	Left gimbal side to side control.
<b>T1</b>	J1 control trim.
<b>T2</b>	J2 control trim.
<b>T3</b>	J3 control trim.
<b>T4</b>	J4 control trim.
<b>LT</b>	Left VR switch.
<b>CT</b>	Center VR switch.
<b>RT</b>	Right VR switch.
<b>RS</b>	Right slider control.
<b>LS</b>	Left slider control.
<b>Multi-I/O</b>	File sharing, trainer and PC interface mode.
<b>DataTran</b>	User can up / down load model setup data thru a PC.
<b>T.Pupil</b>	Aurora in pupil, or training mode.

## Safety Information

Flying models can be dangerous if proper safety precautions are not followed. Here are a few critical safety suggestions to keep you and others safe.

### Are you experienced?

Flying models is not an intuitive process. Most accomplished model pilots were taught by another modeler. We encourage you to seek help during your early flight experiences and if required, during the building and gear installation process. Unlike some other hobbies, model airplane flying has evolved into a social event. There are approximately 2,500 model aircraft clubs in America. Friendship and help could be right around the corner. Ask your local hobby shop about clubs in your area.

### Where to Fly

Having enough land for your own model airport is rare. Most of us fly at club administrated model fields. The local ball field can be tempting but rarely has the space needed and your liability is high should you damage property or hurt an innocent person. We recommend you fly at a sanctioned model aircraft field.

### Join the AMA

In America, the Academy of Model Aeronautics (AMA) is an organization of model enthusiasts that provide resources and insurance to modelers. The AMA also lobbies the Government concerning legislation that impact modelers.

Visit their web site for more information, [www.modelaircraft.org](http://www.modelaircraft.org).

### Academy of Model Aeronautics

5151 East Memorial Drive  
Muncie, Indiana 47302  
Toll Free : 800 435-9262

### Fundamental Guidelines for Safe Flying

1. Don't fly over people or personal property.
2. Make sure you do a range and pre-flight check on your aircraft.
3. Check for others flying on your frequency. (No need with 2.4GHz)
4. Know your batteries condition. Keep them charged.
5. The equipment we use in the R/C hobby is sensitive electronic gear. Have receivers checked after a crash before using them in another aircraft.
6. Use the Fail-Safe function in AFHSS and QPCM mode to lower the throttle in case of a signal "lock-out".
7. Don't fly alone.



## Aurora 9X Transmitter Warnings

The Aurora 9X has a few warning alarms you need to be aware of.

### Start-up warnings

#### High Throttle

If the throttle is positioned above idle during the system "boot-up to transmit" process, a warning beeping will occur and the following warning screen will be displayed.

```
[Condition Warning]NORMAL  
To transmit radio frequency.  
-turn off all switch's condition.  
-descend the throttle stick down.
```

Lower the throttle to proceed.

#### Condition warning at start-up

If you have flight conditions and other mixing programmed for the active model, and they are switched "on" during the "boot-up to transmit" process, a warning beeping will occur and the following warning screen will be displayed.

```
[Condition Warning]Cond-2  
To transmit radio frequency.  
-turn off all switch's condition.  
-descend the throttle stick down.
```

Turn the mixes off to proceed.

### In-flight warnings

If the transmitter should start a continuous beeping during a flight, land immediately and evaluate the cause of the warning.

#### Low transmitter battery tone

When the transmitter battery power descends to a critically low level, a warning beeping will occur.

#### Low aircraft battery tone

If the aircraft on-board battery or SPC connected battery is critically low, Aurora 9X will start beeping during its operation.



If you use Hitec single-direction AFHSS receivers (MINIMA & MAXIMA), the low battery warning will NOT occur.

## Transmitter Battery Information

Your Aurora 9X transmitter is supplied with a rechargeable, 6 cell, AA size, Nickel Metal Hydride (NiMH) battery pack with a nominal voltage of 7.2V.

### Charging Method (CG-SXX series charger)

The preferred charging method is to use the supplied CG-SXX overnight wall charger. Plug it into the port as shown in the diagram. Note the red "charging in process light" on the CG-SXX overnight wall charger. This light will turn green when charging is complete. The battery can be removed from the radio and charged with a "quick" charger. The recommended charge rate should be no more than 2 Amps.

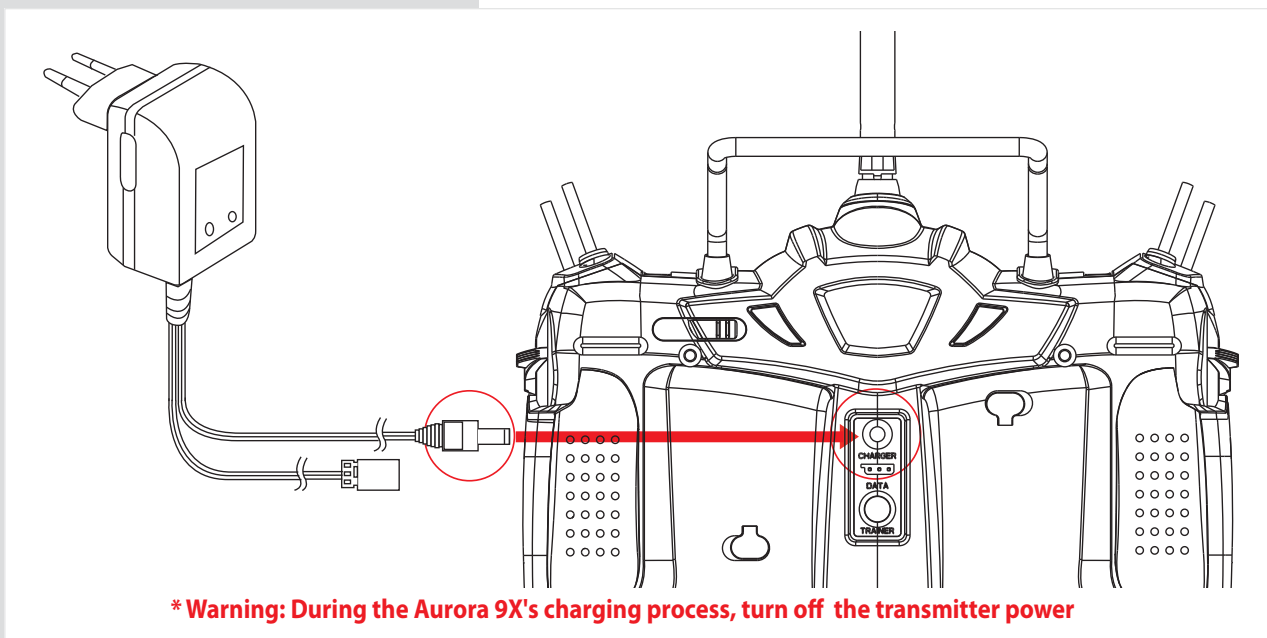

### Power Meter

There are two ways to review the battery voltage on the Aurora 9X home screen. A "direct voltage read out", and a "percentage of available power" graph can be displayed by touching the power icon on the main menu.



### The Li-Po Option

The user has the option to power the Aurora 9X with a 2S Li-Po 7.4 voltage battery, but accepts full responsibility to do so safely. Also you must change the "battery type" on the menu properly.



Do not install a Li-Po in the Aurora 9X and then try and charge it with the supplied CG-XX overnight wall charger. The CG-XX was designed to be used for NiMH cells only! Certain Major damage is sure to occur.

### Hitec 2.4GHz System

The Aurora 9X features our latest robust 2.4GHz AFHSS signal. It is capable of transmitting both our G1 AFHSS technology with the Optima and Minima receivers as well as our G2 AFHSS high frame rate, low latency technology with the Maxima receiver series. Additionally, the Aurora 9X can transmit SLT 2.4GHz protocol, making it compatible with the numerous Tx-Ready™ airplane models.

### Maxima Series Receiver Features



Caution

The Maxima series is designed for use with the Aurora 9X. The older Aurora 9 transmitter cannot be used with the Maxima series receiver. USE ONLY Digital SERVOS with the Maxima receivers. Analog servos cannot be used with the Maxima series receivers.

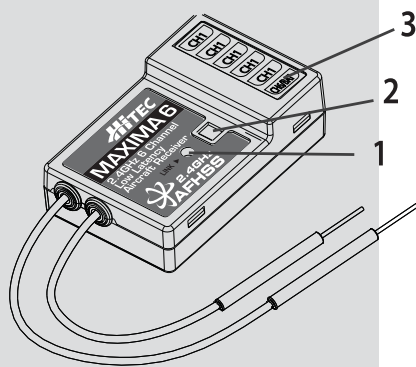

MAXIMA 6

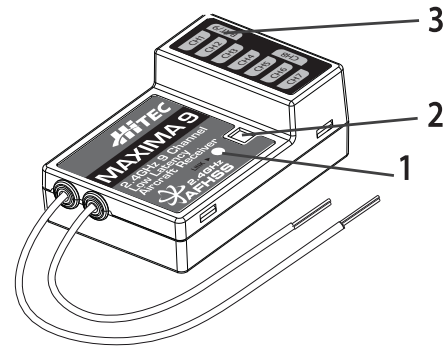

MAXIMA 9

#### 1. Function Button

- Used for binding the receiver to the Aurora 9X and entering the FAIL-SAFE or Hold feature.

#### 2. Dual LED Status Indicator

- Indicates the set-up process codes and current status of the receiver.

#### 3. Channel Output and Battery Input Ports

- The ports for battery power input and servos, gyros and other accessories' output ports are located at the side end of the Maxima receivers.

#### 4. Low Battery Warning

- If the receiver's battery levels fall below 3.6V, the RED LED will flash.

#### 5. FAIL-SAFE/Hold Mode Selectable

- Servos and other accessories position can be set with a FAIL-SAFE point, if power to the receiver is lost.

Hitec 2.4GHz Maxima Series Receiver

**Maxima Series Receiver Antenna Installation**

The Maxima receiver series antenna system was created to provide the optimum signal capture capability. Our two antennas must be installed properly. Refer to the illustration below.

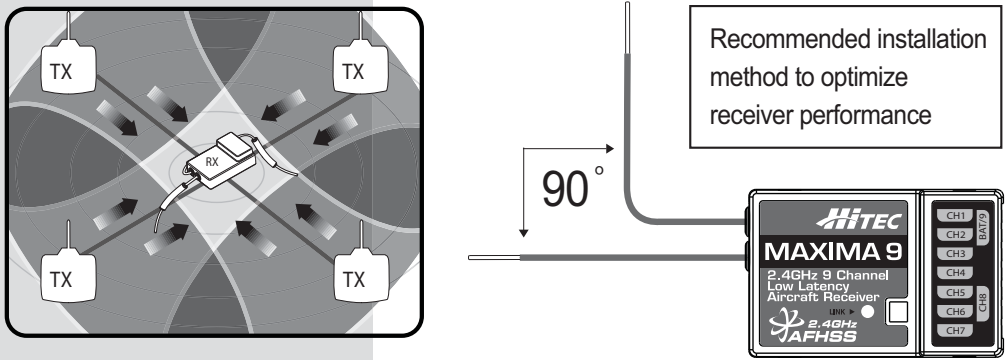

**Maxima Series Receiver Connection Diagrams**

**Electric powered aircraft with Electronic Speed Control**

Use this method on electric planes using ESC's providing power to the receiver and servo functions.

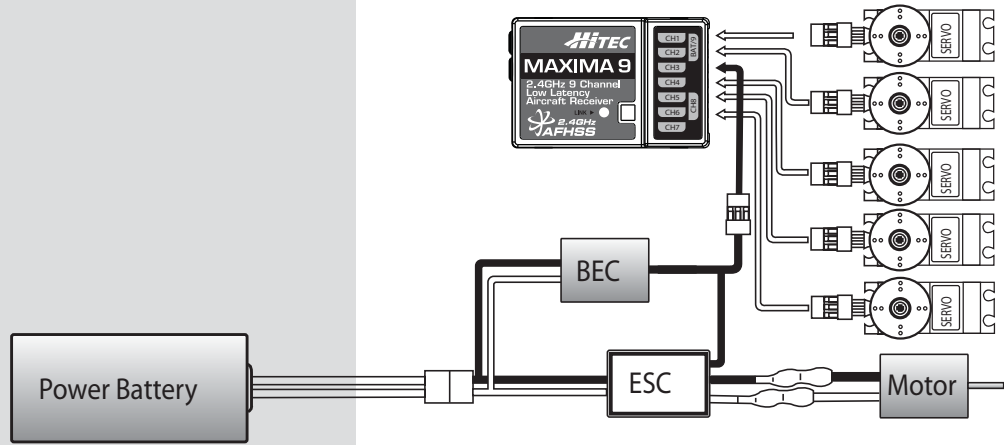

**Glow, gas or electric powered aircraft using a separate receiver battery supply.**

Follow this connection diagram when using a regulated Li-Po, or 4.8 to 6V receiver battery.

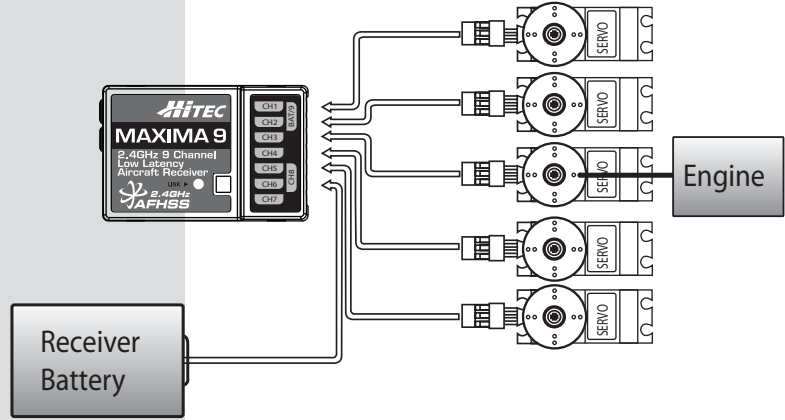

### Hitec 2.4GHz Optima and Minima Series Receiver

#### Optima and Minima Series Receiver Features

The following information contains the complete directions on how to use the Optima and Minima series receivers (version 3.00(0)). We encourage you to review this information before using these products.

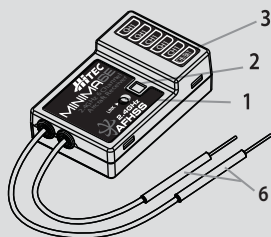

MINIMA 6E & MINIMA 6T  
(6T output block is on top)

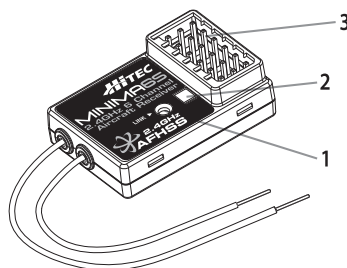

MINIMA 6S

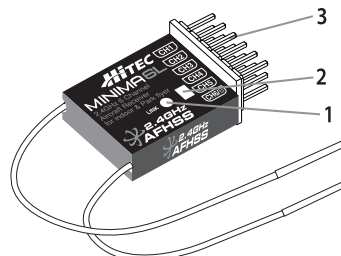

MINIMA 6L

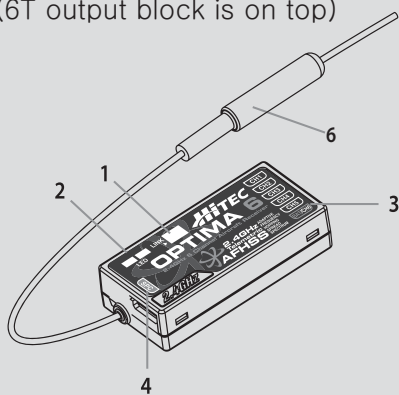

OPTIMA 6 & OPTIMA 6 LITE  
6L utilizes a soft case and  
exposed output block

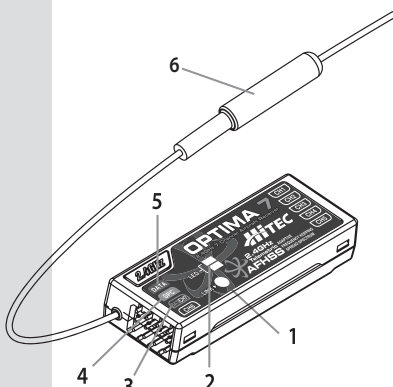

OPTIMA 7

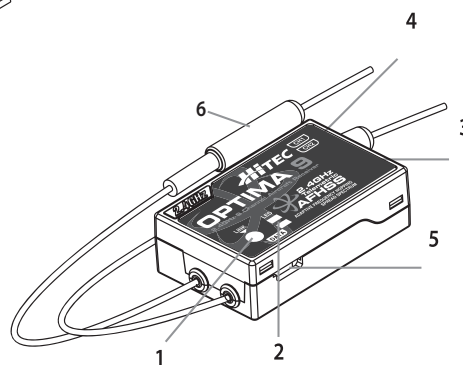

OPTIMA 9

#### 1. Function Button

- Used for binding the receiver to a module or Hitec 2.4 built-in transmitters, entering the FAIL-SAFE or Hold feature.

#### 2. Dual LED Status Indicator

- Indicates the set-up process codes and current status of the receiver.

#### 3. Channel Output and Battery Input Ports

- The ports for battery power input and servos, gyros and other accessories' output ports are located at the side.

#### 4. SPC (Supplementary Power Connection)\*

- Power the Optima and Minima receivers function with up to a 35V. electric aircraft motor battery.

#### 5. Telemetry Sensor and Data Port\*

- A three pin servo plug connector port is featured on the Optima 7 and Optima 9. (Optima 6 is not applicable.)

Using the HPP-22 PC interface accessory, this port serves to facilitate upgrading the device's software and interfacing the optional onboard sensor station.

## Hitec 2.4GHz Optima and Minima Series Receiver

### 6. BODA (Boosted Omni Directional Antenna) System\*

- Hitec's exclusive 2.4GHz BODA System will show you another way of using our 2.4GHz systems. The single Omni-directional antenna booster makes it much easier to install the 2.4GHz antenna. Intensive tests have proven that the single BODA system in our 6 & 7 channel systems is better than or equal to our competitor's dual antenna systems while our Optima 9 receiver features a dual BODA system to give the added security that larger models need. Installation is easy and simple, insert the antenna into the supported antenna holder and stick it to the desired spot you wish to install.

### Compatibility

- The OPTIMA & MINIMA receivers are compatible with transmitters using the Hitec AFHSS 2.4 GHz system, such as, Spectra 2.4 module or dedicated built-in module AFHSS 2.4 Hitec transmitters.

### FAIL-SAFE/Hold Mode Selectable

- Servos and other accessories can be set with a FAIL-SAFE point, if power to the receiver is lost.

### Low Onboard Battery Warning Function

This function lets you know when the on-board battery is low with a warning alarm from the transmitter while you are flying. Review the Low Battery alarm features that use direct telemetry feedback to your transmitter.

### Jumper\*

The jumper is installed at the factory and is used when the receiver is powered by an electronic speed control, a commercially available B.E.C. (battery eliminator circuit), dedicated 4.8 to 6V. NiMH battery pack, or regulated Li-Po battery. The jumper is removed when the receiver is powered using the SPC feature.

\*These functions/ features are only for OPTIMA series receivers

## Common Receiver Connection Diagrams

### Electric powered aircraft with Electronic Speed Control

Use this method on electric planes using ESC's providing power to the receiver and servo functions.

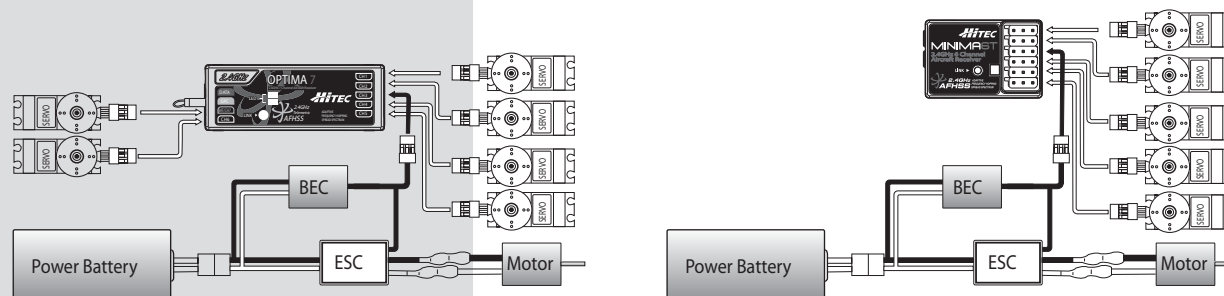

### Glow, gas or electric powered aircraft using a separate receiver battery supply.

Follow this connection diagram when using a regulated Li-Po, or 4.8 to 6V receiver battery.

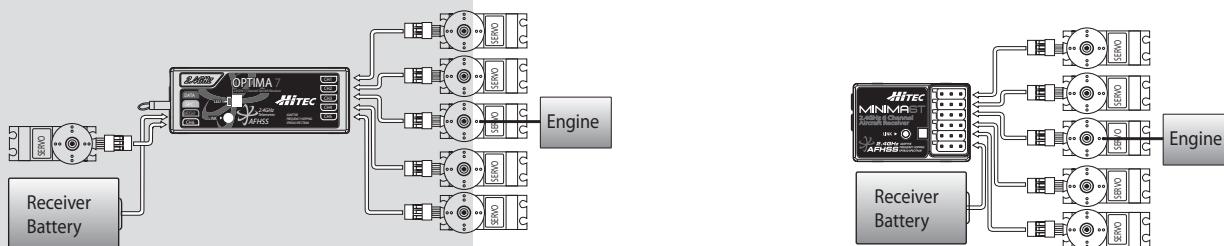

### Hitec 2.4GHz Maxima Series Receiver

#### Maxima Series Receiver Link (ID-Setting)

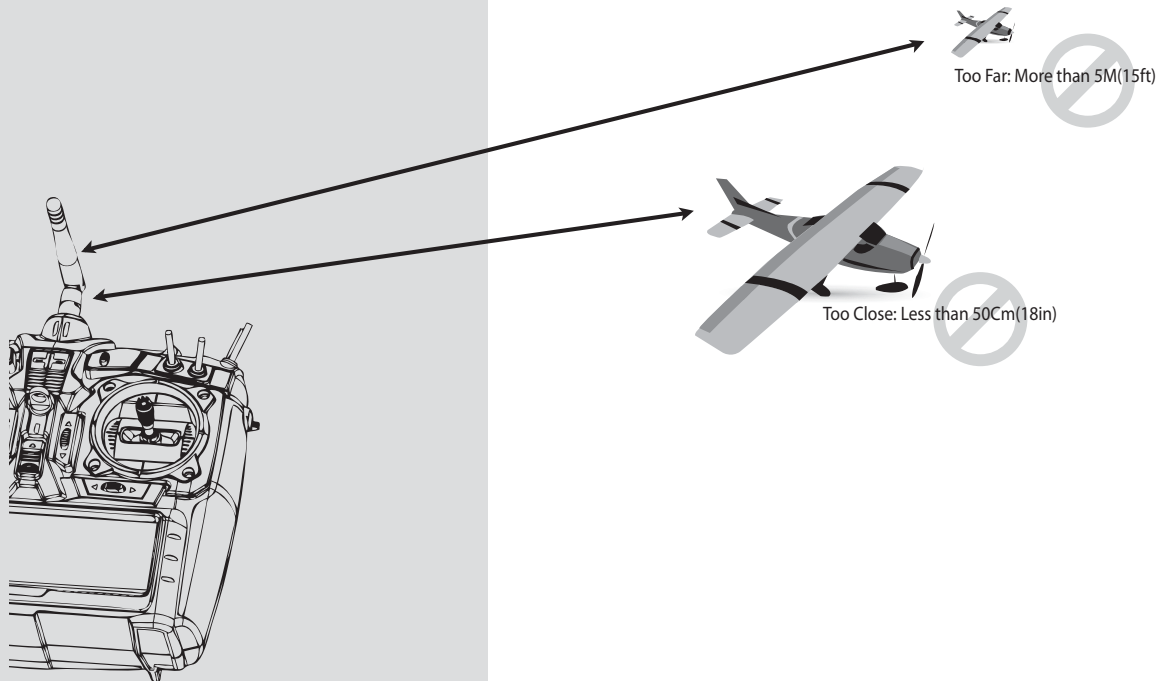

- Link must be done within 15ft(5m) of the transmitter and receiver.
- Transmitter and receiver need to be at least 18in(50cm) from each other to link properly.

#### Maxima Series Receiver Link (ID-Setting or Bind)

Your Hitec AFHSS system uses a communication protocol that links and binds the Hitec 2.4GHz receiver to your transmitter. Once the receiver and transmitter are "bound", no other transmitter can interfere with your receiver during its operation. In the case of multiple model memory transmitters, you can bind as many Hitec 2.4GHz receivers to your transmitter, one per model memory as necessary. Each transmitter and receiver set is paired at the factory for your convenience.

Use one of the following binding methods to bind additional Hitec 2.4GHz receivers to your transmitter.

1

Turn On the transmitter, and touch the "Yes" in Transmitter

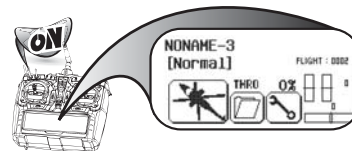

2

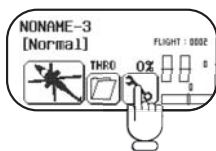

Touch the System menu.

3

Touch the "Spectra" icon.

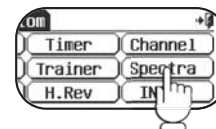



Hitec 2.4GHz Maxima Series Receiver

4

Touch the "arrow" to select the type of receiver you wish to bind to, then touch "Binding" icon and then touch "Yes" for Binding.

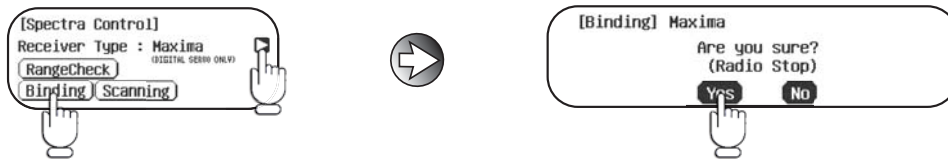

5

Press and hold the link button on the Receiver and turn on the power.

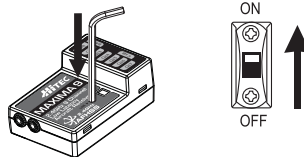
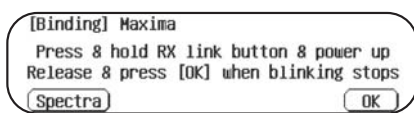

6

Release the link button. Both RED and BLUE LEDs will be blinking rapidly to find the transmitter's signal.

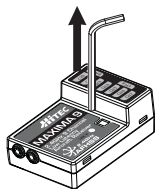

7

When the LED stops blinking, press OK. The blue LED will glow solid.

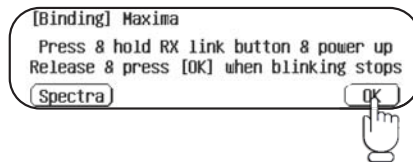

8

Turn the power to the receiver off, then back on. Check for a solid blue LED light.

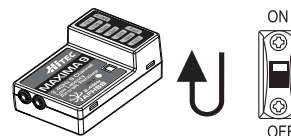
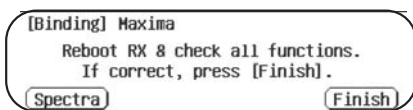

If all functions work well press the (Finish) icon on the screen to finish binding.

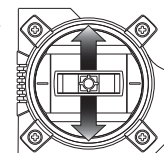
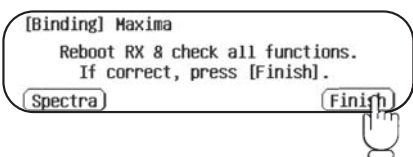

Control Check



Good work



If all functions "Do not" work well, Please go back to step "6" and repeat the binding again

### Hitec 2.4GHz Optima and Minima Series Receiver



#### Optima and Minima Series Receiver Link (ID-Setting or Bind)

- 1** Turn On the transmitter, and touch the "Yes" icon in Transmitter.

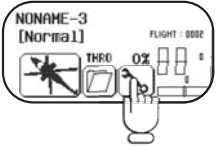
- 2** Touch the System menu.

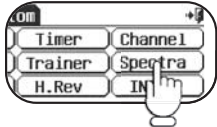
- 3** Touch the "Spectra" icon.

- 4** Touch the "arrow" to select the type of receiver you wish to bind to, then select either Optima or Minima.

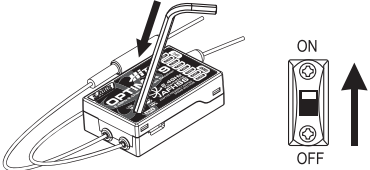
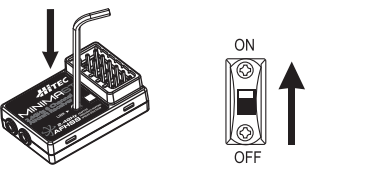
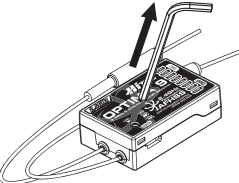
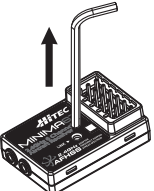
- | <b>5</b> OPTIMA   | <b>MINIMA</b>   |
|---|---|
| <p>[Binding] Optima</p> <p>Are you sure?<br/>(Radio Stop)</p> <p>Yes No</p>  | <p>[Binding] Minima</p> <p>Are you sure?<br/>(Radio Stop)</p> <p>Yes No</p>  |
| Touch "Yes" For Binding   |   |
- |   |   |
|---|---|
| <p>[Binding] Optima</p> <p>Press receiver's link button and turn on the power.</p> <p>Spectra</p>  | <p>[Binding] Minima</p> <p>Press &amp; hold RX link button &amp; power up. Release &amp; press [OK] when blinking stops.</p> <p>Spectra OK</p>  |
| Press and hold the link button on the Receiver and turn on the power.   |   |
- |  |  |
|--|--|
| <p><b>7</b> Release the link button.</p>  | <p>Release the link button.</p> <p>Both RED and BLUE LEDs will be blinking rapidly to find the transmitter signal.</p>  |
|--|--|

Hitec 2.4GHz Optima and Minima Series Receiver

8

For the Optima series Receiver, when binding is done, it automatically goes to the next page (The BLUE and RED LEDs will be solidly on)

[Binding] Optima  
 Reboot RX & check all functions.  
 If correct, press [Finish].

Spectra Finish

When LED blinking stops, press [OK] (Blue LED will be solidly on)

[Binding] Minima  
 Press & hold RX link button & power up  
 Release & press [OK] when blinking stops

Spectra OK



9

Turn off the power to the receiver; turn it back on and check that the red LED is on.

[Binding] Optima  
 Reboot RX & check all functions.  
 If correct, press [Finish].

Spectra Finish

Turn off the power to the receiver; turn it back on and check that the blue LED is on.

[Binding] Minima  
 Reboot RX & check all functions.  
 If correct, press [Finish].

Spectra Finish

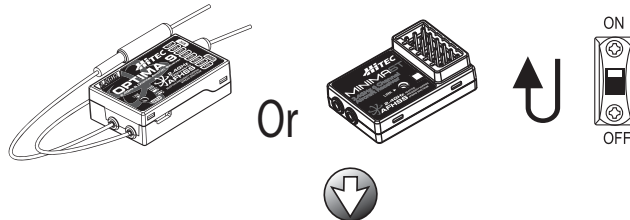

If all functions work well, press the the Finish icon on the screen to finish binding.

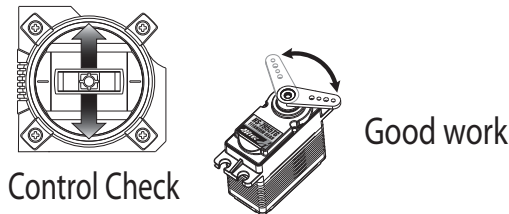

[Binding] Optima  
 Reboot RX & check all functions.  
 If correct, press [Finish].

Spectra Finish



Or

[Binding] Minima  
 Reboot RX & check all functions.  
 If correct, press [Finish].

Spectra Finish



 If all functions "Do not" work well, Please go back to step "6" and repeat the binding again

Caution

### Hitec 2.4GHz System

#### FAIL-SAFE and Hold Mode Setup

If you use and set up the FAIL SAFE function properly and the receiver signal is somehow interrupted, the servos will move to your previously stored FAIL-SAFE setup.

If you do not activate the FAIL-SAFE function, the signal is switched off after the HOLD period of 1 sec. This means that the servos become "soft" and remain in their last commanded position under no load (this may equate to full-throttle!), until a valid signal is picked up again.

In the interests of safety, we recommend that FAIL-SAFE should always be activated, and the FAIL-SAFE settings should be selected so as to bring the model to a non-critical situation. (e.g. motor idle / electric motor OFF, control surfaces neutral, airbrakes extended, aero-tow release open, etc.)

**1**

Switch on both.  
Wait for the system to boot and you have control over the model.

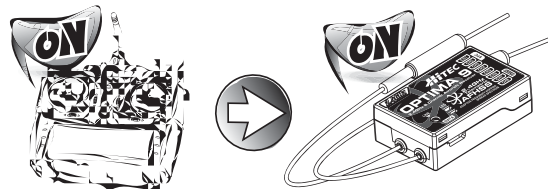

**2**

Press and hold the button on the receiver until the LED turns off (approx. 6 seconds).



**3**

Release the button. After 2 seconds both red and blue LEDs blink alternately. The receiver will count 5 seconds. During that time, move all the transmitter sticks and other controls to the desired FAIL-SAFE positions (e.g. motor idle, control surfaces neutral), and hold until the blinking stops.

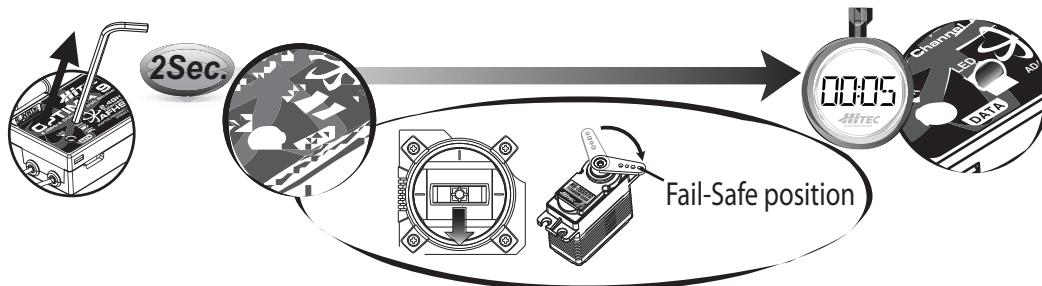

**4**

When the blinking stops, the system will temporarily remember the FAIL-SAFE position. Turn off the system to save and exit.

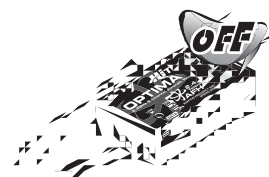

## Hitec 2.4GHz System

### Testing the FAIL-SAFE Setting

- a. Move the sticks to positions other than the FAIL-SAFE settings, and then switch off the transmitter.  
The servos should now move to the FAIL-SAFE positions previously stored, after the one second HOLD period.

### How to turn FAIL-SAFE Off and reactivate the Hold Mode

- a. Switch on the transmitter, then the receiver. Wait for the system to boot and you have control over the model.
- b. Press and hold the receiver function button for 6 seconds and release it. After 2 seconds the red and blue LEDs will blink rapidly.
- c. Immediately press the button once.
- d. FAIL-SAFE Mode is now deactivated and HOLD mode is activated.
- e. Turn the transmitter off, then the receiver off.
- f. Turn the system back on to use it.



Note

- If FAIL-SAFE is deactivated, the FAIL-SAFE position settings are also deleted!
- The FAIL-SAFE settings should be checked every time before you run the engine/motor.

## Telemetry System

The Hitec Spectra 2.4 System and Optima Series receivers feature full telemetry capabilities (except Optima 6) and include a Low Receiver Battery Warning as a basic function.

### I. Basic Function: Low Onboard Battery Warning - for All Optima Receivers

When the Optima series receiver is powered up, it will automatically detect the battery voltage level and recognizes between 4 cell or 5 cell NiMH and NiCd batteries. (4 cell < 5.8V < 5 cell)

In case of a 2 cell LiPo battery being used, you can customize the battery warning level by using HPP-22 PC program.

- When battery level is safe (4 cell > 4.5V, 5 cell > 5.6V): no changes for LED lights.
- When battery level is low (4 cell < 4.5V, 5 cell < 5.6V): Blue LED glows constantly and the red LED will blink fast. You will hear three-continuous beeping alarms from the module as a low receiver battery warning. Upon hearing the alarm, we advise you to land at once.

### II. Optional Functions: (Available with Optima 7 and 9)

Hitec offers a wide variety of telemetry sensors designed to work with both fuel and electric powered aircraft. Check our website at [www.hitecrcd.com](http://www.hitecrcd.com) for the latest available telemetry accessories.



Note

- The telemetry function is applicable for OPTIMA series receivers only.



Warning

- Low Battery Warning function is only for your guidance. The actual battery voltage level could be different.
- When the 2.4GHz system and High Voltage servos are used together, we strongly recommend using fully charged large capacity battery packs.

### Hitec 2.4GHz System

#### Range Check Function

It is critical that before each flight session you perform a range check that confirms the signal between the receiver and transmitter is appropriate. Unlike the FM/PPM or PCM signal radios, 2.4GHz systems use a fixed shorter, stubby transmitter antenna so the traditional method of range checking your system by lowering the transmitter antenna will not work.

We instead use a power-down mode to reduce the transmitter signal strength. During this power-down mode, you should walk away from the secured aircraft carrying the transmitter to a distance of approx. 30 meters, testing the effective range.

- a. Note the system menu function choices, select, **Spectra**.

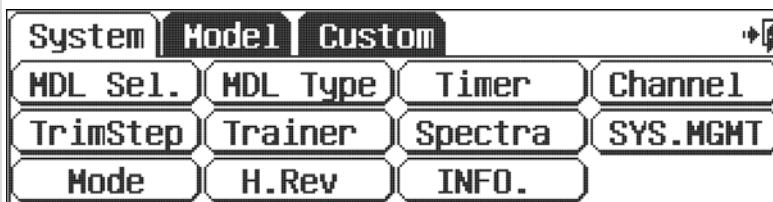

- b. Press the Range Check icon.

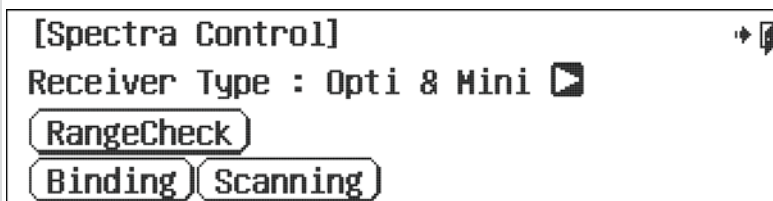

- c. Press the "Yes" icon.

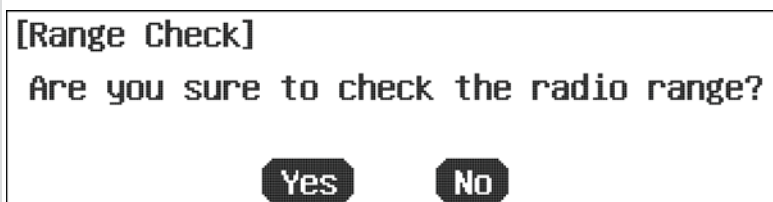

- d. Press the Start icon and finish Stop.

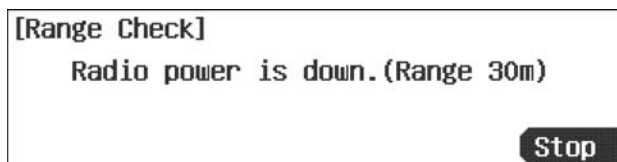
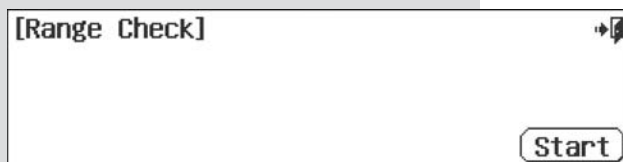

**Hitec 2.4GHz System**

**Scan Mode**

In Scan Mode the transmitter and receiver will scan all available channels every time you turn it on. It will then choose the cleanest frequencies to use. Scan Mode is preferable to use when flying in a crowded 2.4GHz environment.

a. From the System menu function choices, select, **Spectra**.

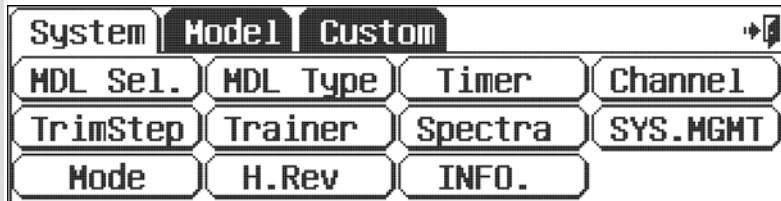

b. Press the Scanning icon.

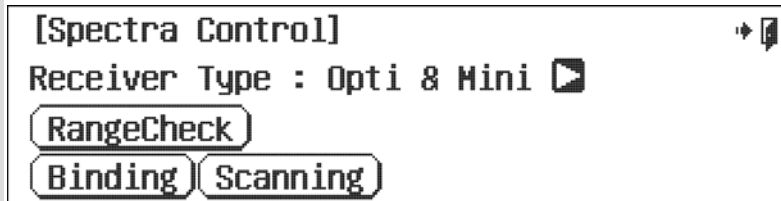

c. Press the "Yes" icon.



The radio will stop transmitting during the scanning operation.



The radio will now scan for a clear frequency table.



While scanning is in progress you must leave the transmitter alone. Do not push any icons, buttons, switches or sticks.

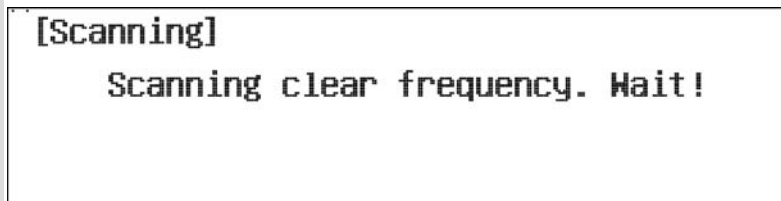

d. Once scanning is complete press the receiver's link button and turn on the power.

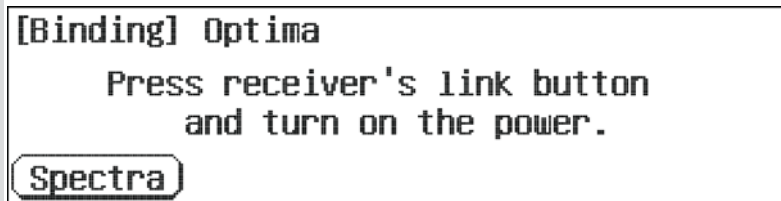

e. If Scan Mode link is successful you will be prompted to reboot the receiver.

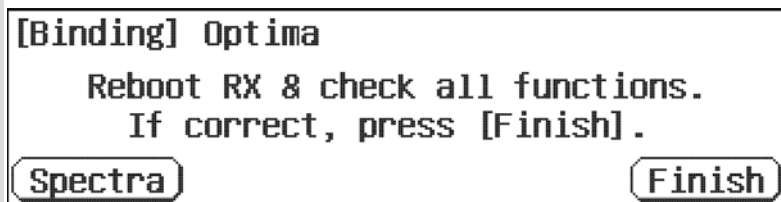

f. Check to see that all functions are operating correctly. If they do, press **Finish**. You now have successfully bound your receiver in scan mode.



## Hitec 2.4GHz System

### SLT Technology

In addition to our proprietary AFHSS technology the Aurora 9X has the ability to transmit using Secure Link Technology (SLT). This allows you to fly the numerous Tx-Ready models available on the market. For more information visit [Tx-Ready.com](http://Tx-Ready.com) for models utilizing this technology. Follow these instructions to utilize SLT with your Aurora 9X.

- a. Follow the instructions in sections a. & b. on page 25 to enter the Spectra setup menu. Press the ► icon until SLT is displayed.

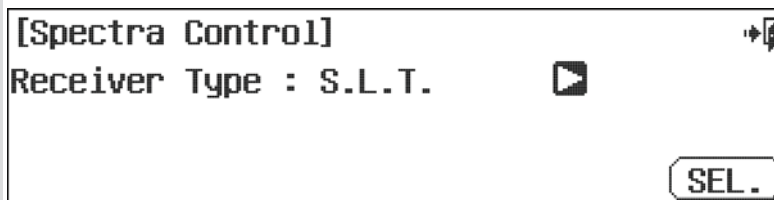

- b. When prompted press **Yes** to transmit in SLT mode.

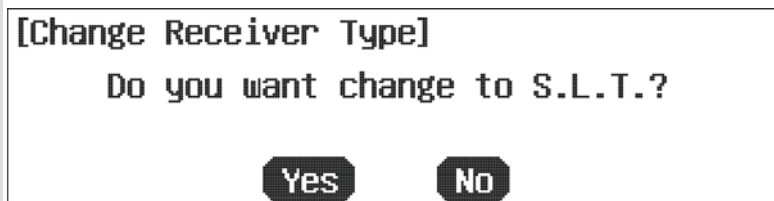

- c. You will then be taken back to the opening screen and it should show SLT as the modulation. If you are ready to transmit press **Yes**.

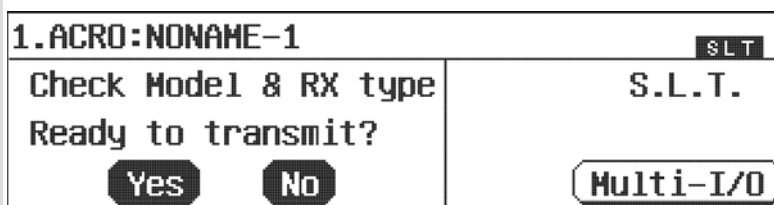

### SLT Receiver Binding

The following procedure is for binding typical SLT receivers to the Aurora 9X. These methods may vary from manufacturer to manufacturer. Check your receiver manual for any variances to these instructions.

1. Turn on the Aurora 9X transmitter and when prompted to transmit choose YES.
2. Apply power to the Receiver.
3. If the receiver LED flashes once and then stays on, the receiver is already linked to the transmitter and you can skip to the next section. Otherwise, insert a small diameter screwdriver into the hole marked "LINK" or "BIND" on the receiver and press the button until the LED on the receiver glows red and then turns off after about one second.
4. Release the "LINK" or "BIND" button.
5. If the linking is successful, the receiver LED will flash once and then remain ON.
6. Test for proper functionality before use. If the radio doesn't appear to have become properly linked, repeat steps 1-6 above and move the transmitter at least three feet away from the receiver.

**Aurora 9X Transmitter Controls**

- 1. A, B C, D, E, F, G, H, switches
- 2. J1, J2, J3, J4 gimble
- 3. Neckstrap hook
- 4. LS and RS sliders
- 5. All Digital trims, T1, T2, T3 and T4
- 6. On-Off switch

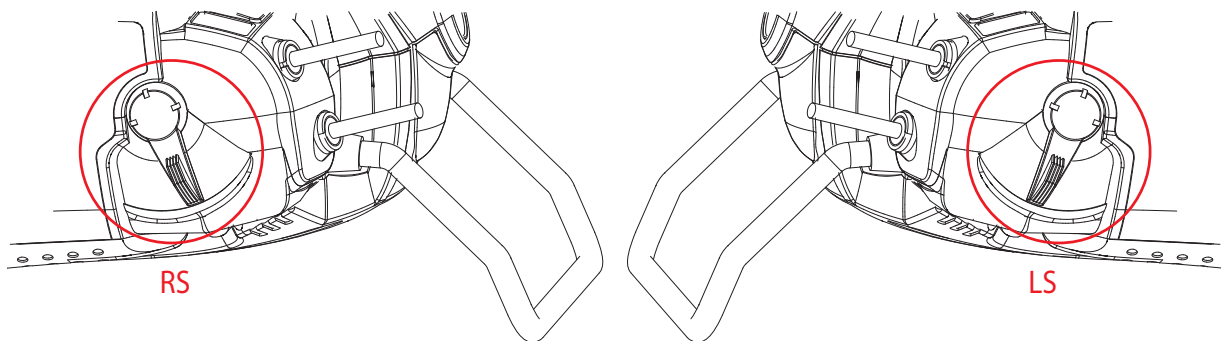
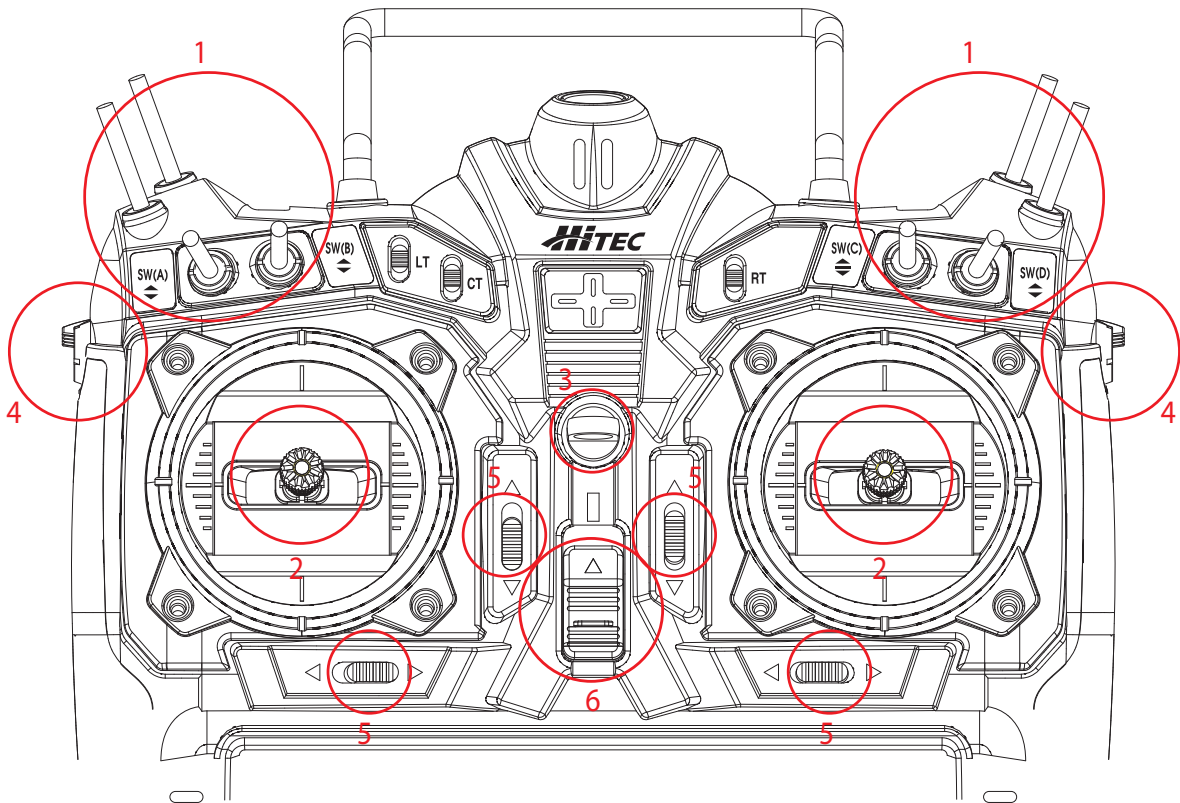

**Slider Volumes**

Side sliders are used as variable controls on several of the functions by default but can be changed if you wish. Like all of the Aurora 9X controls, you can choose an almost infinite number of control layouts.

### Aurora 9X Transmitter Controls

#### LT, CT, RT Switches

These switches can be used as a channel control and are used as adjustment controls for fine tuning many of the Aurora 9X features.

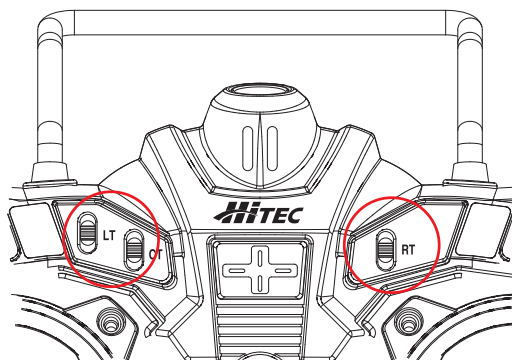

#### Digital Trims

The Aurora 9X features digital trims on the face of the transmitter for throttle and the three main control functions of pitch, roll and yaw.

- A gentle pull to one side of the switch will cause the control surface to move one trim step and the radio to “beep” once.
- Hold the switch over to one side to rapidly trim a control surface.
- The size of the trim step can be adjusted in the System – TrimStep function menu.
- The graph on the screen will indicate how much movement is applied to the control surface by the trim function.
- The last trim position will be saved in memory should you switch to another model.

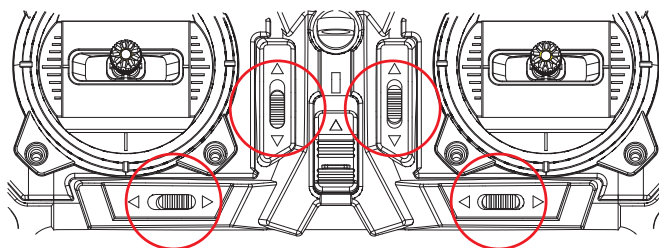

#### Stick Length Adjustment

Everyone's hand size is unique, so to accommodate everyone we use a two piece stick “top” that can be adjusted to fit a wide variety of users.

- Separate the top from the bottom piece and adjust the top piece to the length required.
- Screw the bottom up against the top piece to “jam” lock everything into position.

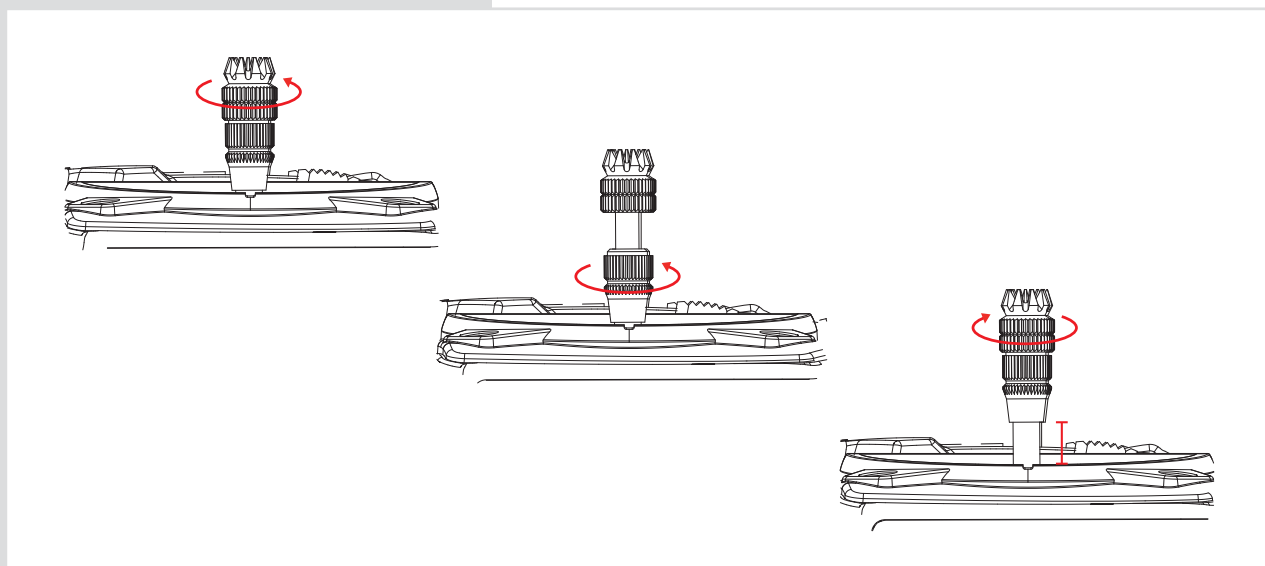

## Aurora 9X Transmitter Controls

### Stick Tension Adjustment

- Remove the rubber pads by gently pulling up a corner and slowly pulling them off.
- Use a 1.5mm Hexa wrench to turn the adjustment screw clockwise to increase the spring tension, and counterclockwise to decrease the tension of the spring.
- Fit the rubber grip pads back into place when finished.

### Control Mode Changes

The Aurora 9X offers unlimited options when customizing the gimble control functions for Mode 1, 2, 3 and 4 users. In addition, the Aurora 9X also features two manual mode set-up menus. These are all located in the System menu - Model Set up Menu.

- Easy ratchet adjustment for the throttle on each gimble.
- In America, the radio is factory set in Mode 2.

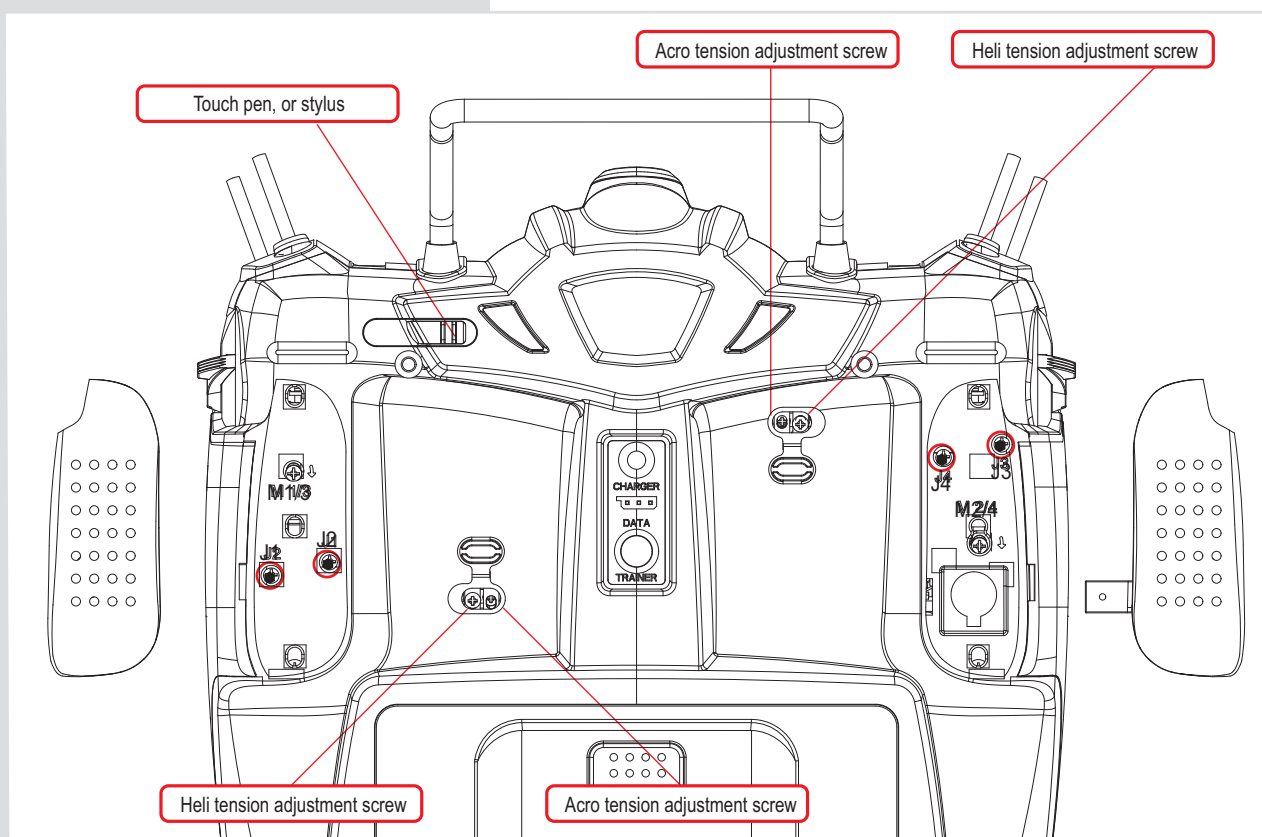

### Stick Ratchet Adjustment

Throttle ratchet tension can also be adjusted to accommodate different flying styles. Some users prefer a very stiff, positive detent in the throttle stick; while heli users often use a very light, sometimes smooth throttle/collective stick "feel".

- Peel up the correct rubber dust cover over the throttle stick tension adjustment screws for the mode you are flying. The radio is factory set-up for the popular mode 2 control format.
- There are two adjustment screws. Note in the diagram which one you want to adjust.
- Use a small Phillips head screwdriver to turn the adjustment screw clockwise to increase the ratchet tension, and counterclockwise to decrease the tension of the ratchet.
- To switch from airplane to heli, or heli to airplane, turn the appropriate screw counterclockwise until the stick movement is smooth, then turn the other screw clockwise to apply ratchet pressure and adjust as necessary.

### Touch Screen Lock

This function limits any undesirable operation by pressing the touch screen buttons during flight. Users can activate and setup this function as follows:



Caution

If you set up the Touch Screen Lock function, it prevents the user from accidentally activating a Tx function on the screen.

#### Touch Screen Lock Setup

a. Select SYS.MGMT from the systems menu



b. Use the arrow icon to activate the function. When the Touch Lock setup time reaches 5 seconds and no input time is detected, lock function will activate. (Touch Lock activation time can be adjusted among 5, 10, 20 second, 1minute, and function off)

c. When the Touch Lock function is properly activated, the following phrase will be displayed.

Touch Lock is activated.

d. If you accidentally press the touch screen when the lock is active, the following phrase will be displayed, "Touch Lock is activated. Press & hold the screen to deactivate."

Touch Lock is activated.  
Press & hold the screen to deactivated.

e. You can unlock the screen lock by pressing and holding the screen for about 2~3 seconds. After that, you can set up the Aurora 9X and the Touch Lock function will activate if there is no screen input.



Caution

The Touch Screen Lock function is not active if the Aurora 9X is not transmitting.

## The First Screen

When you first turn on the Aurora 9X, the following screen will appear and you can find the information below.

### In AFHSS mode (with Maxima RX) :

1. The upper line has the number and name of the active model on the left.
2. The current 2.4GHz mode type you are using appears in the upper right corner and the pre-set MAXIMA will appear right below.
3. You are asked "Ready to Transmit" by selecting the Yes or No icon.

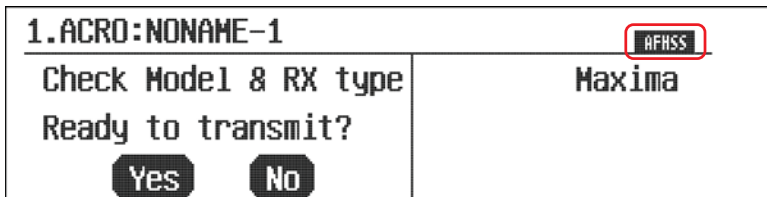

### In AFHSS mode (with Optima or Minima RX) :

1. The upper line has the number and name of the active model on the left.
2. The current 2.4GHz mode type you are using appears in the upper right corner and the pre-set OPTIMA or MINIMA will appear right below.
3. You are asked "Ready to Transmit" by selecting the Yes or No icon.

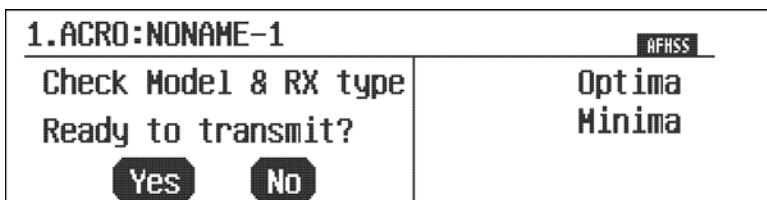

### In SLT mode :

1. The upper line has the number and name of the active model on the left.
2. The current SLT mode you are using appears in the upper right corner and the pre-set RX's name will appear right below.
3. You are asked "Ready to Transmit" by selecting the Yes or No icon.

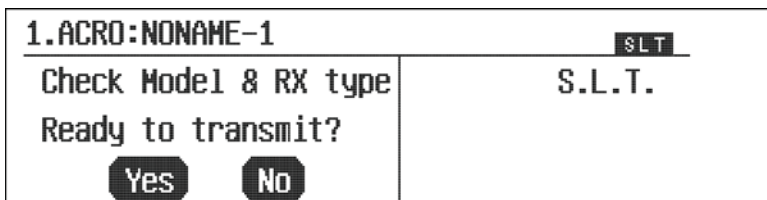

## First Screen Additional Menu

### The Multi-I/O port

The Aurora 9X displays a Multi-I/O format that is shown in the first screen of all AFHSS and SLT modes.

#### To access the Multi-I/O port screen:

- Plug in the trainer cord or HPP-22 PC interface in the "trainer" port of the Aurora 9X on the back.
- Turn on the Aurora 9X.
- Press the Multi-I/O port icon to access.
- Press the Data Tran icon to transfer data between radios or to save/load data from a PC.
- Press the T.Pupil icon to set the Aurora 9X in student mode.

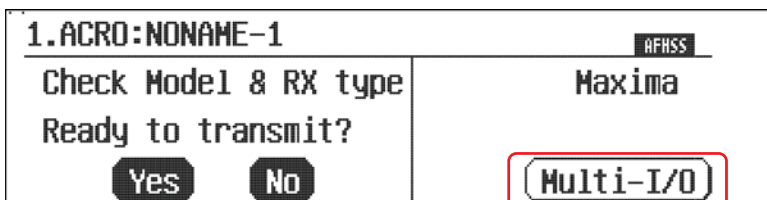



### Multi I/O Screen Menu

#### DataTran

Select Data Tran to transfer the model set up data between two AURORA's, or to save or load data to a PC.

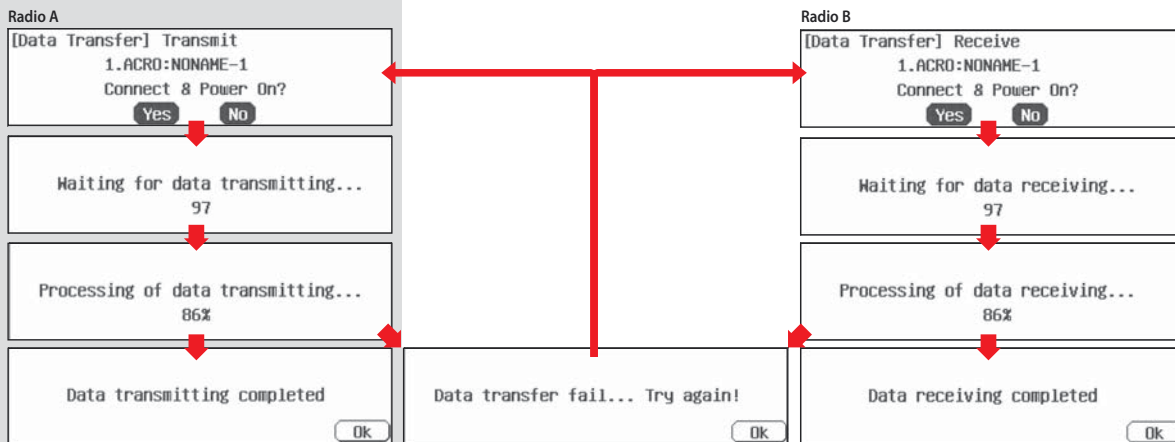
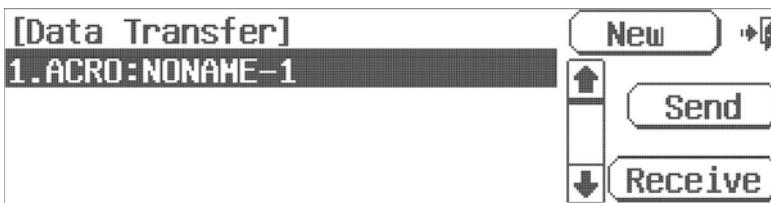

#### T.Pupil

Selecting T.Pupil forwards the radio back to the home screen in the training mode. This is used to place an Aurora 9X in the student format.

This function is not used when the Aurora 9X is used in the master format. For more information on how to use the Aurora 9X training system mode.

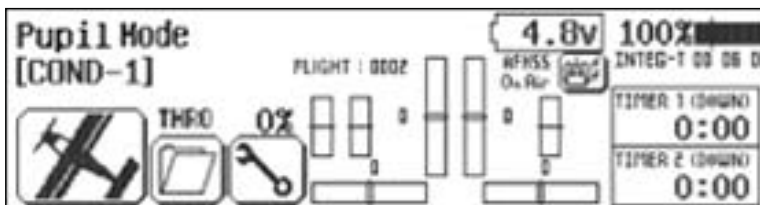
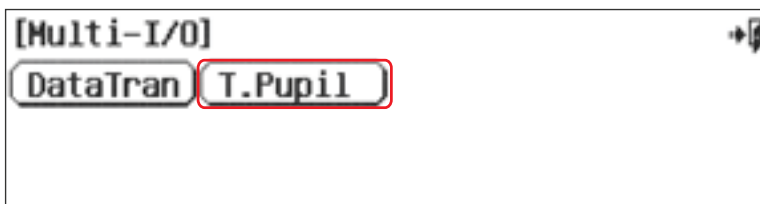

Note

In the pupil mode some functions will be restricted.



## Home Screen Menu

### Home Screen Menu

On the main screen of the Aurora 9X, you can get a variety of information more quickly and easily using the icons which are optimized for the touch screen system.

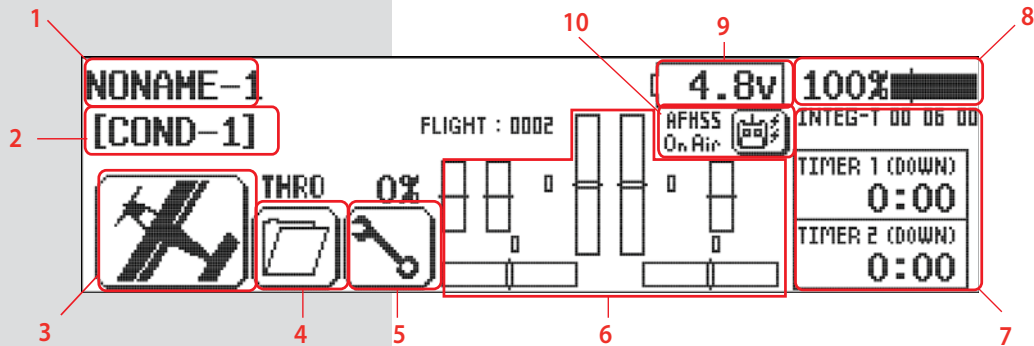

#### 1. Model Name

- Displays the current model's name.
- Press to select the model choice menu.

#### 2. Flight Condition

- Displays the current flight condition for the active model.
- Press to access the flight condition menu.

#### 3. Aircraft Type Icon

- Will be either ACRO, GLID or HELI depending on active model type selected.
- Press to access the Model function menu.

#### 4. Custom Folder

- Contains model functions copied over to the Custom folder for the active model.
- Press to select the Custom menu.

#### 5. System Menu

- Press to access the System functions menu for the active model.

#### 6. Digital Trim Position Indicators

- Shows the position of the digital trims on the throttle and three main flight controls, roll, pitch and yaw.
- Press to access the sub trim menu.

#### 7. INTEG-Timer

- Displays the "total time on" for your Aurora 9X transmitter. It can be reset in the Timer menu. Timer 1 and Timer 2
- Press to access the timer 1 and 2 menus.

#### 8. Power Bar Indicator

- Press to select between percentage of power left or voltage displays.

#### 9. Receiver Battery Power Indicator

- Displays the receiver battery level.
- \* Available when using Optima receivers

#### 10. Active or Inactive Transmit Icon

- Displays the transmitter's transmit status.
- If the icon is dark, the Aurora 9X is not transmitting.
- If the icon is clear with lightning bolts and the "on air" text, the Aurora 9X is transmitting.



Caution

Touch Screen Lock function is not activated if Aurora 9X is not transmitting the frequency. When you find out Touch Screen Lock function is not working, please set frequency transmit on.

### Quick Start Guide to Set up a Simple Powered Airplane or Glider

#### Section Two

To help you get the maximum benefit from your Aurora 9X, we will guide you through a simple set-up of a standard sport plane. The operations shown during this exercise will help you learn many of the basic programming steps required by most of the Aurora 9X's features.



Note

If you are setting up a powered or un-powered glider, we will be programming your plane into the ACRO menu for our demonstration. Later you can explore the functions found in the GLID menus.

Receiver channel assignments are:

#### Simple Powered Plane with one or two aileron servos.

- #1 Aileron
- #2 Elevator
- #3 Throttle
- #4 Rudder
- #5 Second Aileron (if used)

#### Simple two channel un-powered glider.

- #1 Aileron (plug your rudder or aileron servo in ch. 1)
- #2 Elevator

After installing the servos and accessories in your aircraft, follow these steps to set up your first airplane.



Warning

For safety reasons during this set-up exercise on an electric powered plane, remove the propeller.

### System Programming Menu

1. Turn on the transmitter;  
do not turn on the airplane.

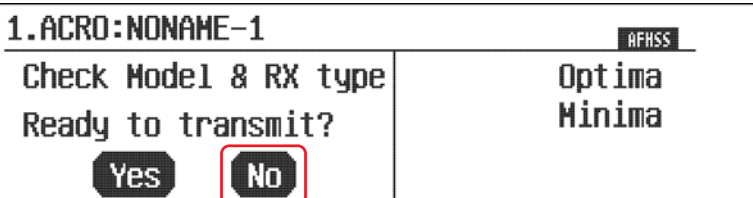

2. The first screen is the transmit option,  
select **No**.

3. This is the home screen first;  
select the **wrench icon** for the System menu.

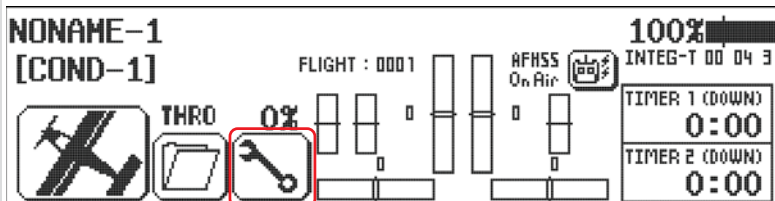

4. Note the system menu function choices,  
select, **MDL Sel.**



## System Programming Menu

5. At the model selection screen press, **New**.

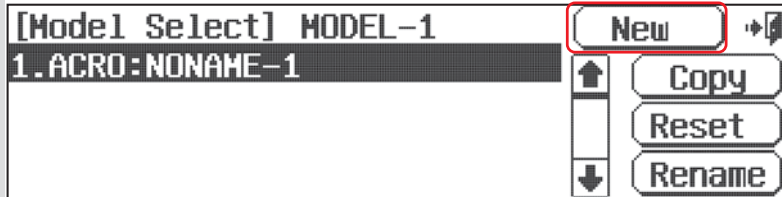

Note

We are programming a new model into the model memory slot number two, not the model memory slot one. For the purpose of this exercise it will ensure a fresh model memory with no existing programming.

6. Select, **Yes** to confirm the selection of a new model.

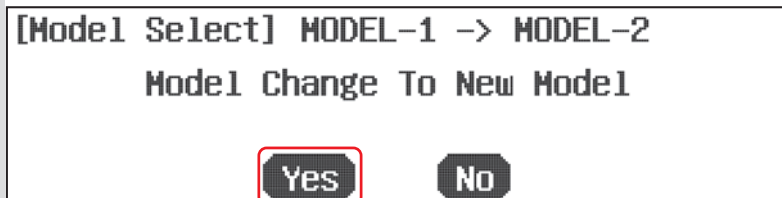

7. At the Model naming menu, name your new model using the keyboard.

- Press **Shift** to see the other characters. Press Caps Lock to see the capital letters.
- When done press, **Enter**.



8. At the transmit option screen, press, **No**. You do not wish to transmit yet.

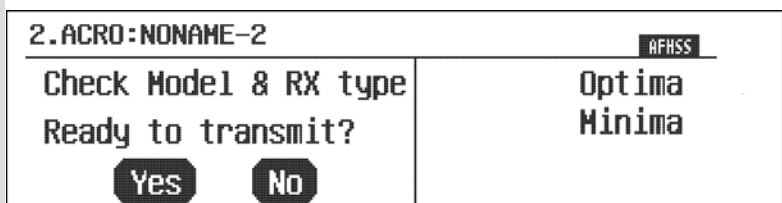

9. Next you are drawn into the model type screen where we select **ACRO** (the airplane icon on the left).



10. Select change to ACRO, **Yes** at the model type change confirmation screen.



### System Programming Menu

11. Here is the screen that will tell the transmitter what kind of wing your plane has.

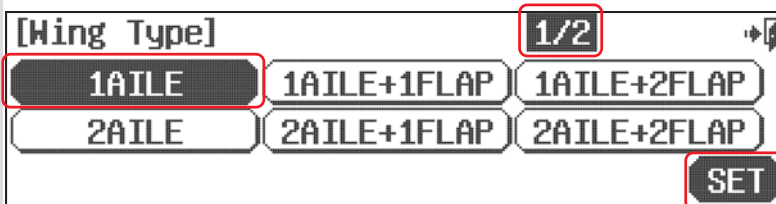

Note

There is a **1/2** icon in the upper right of the screen. This means there are two pages in this menu. Touch the **1/2** icon and note the second screen has even more wing type selections. Many function menus will have more than one screen of options. Check for the **1/2**, or fraction icon as you program your plane into the radio.

- a. For our sample plane, you must select how many servos your wing has and what they control. Select **1AILE** if you have one aileron servo controlling both ailerons. OR **2AILE** if your plane has 2 aileron servos in the wing.
- b. Then press the **SET** icon.



Note

Depending on what you select in this, and for the following menu choices, the radio will automatically optimize the functions for your choices. In other words, if you select a wing type without flaps, there will be no flap function control options in that model's memory programming.

12. Next, select your plane's tail type.

- a. Select **Normal**.
- b. Again press **SET**.

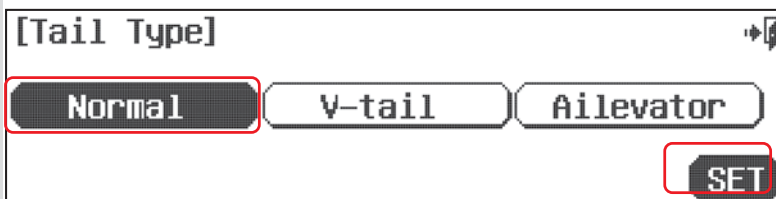

13. At the engine type screen,

- a. Select, **Single Engine**.
- b. Press **SET**.

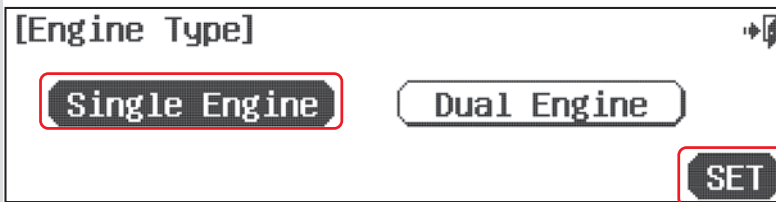

14. Retracts? Press **No**.

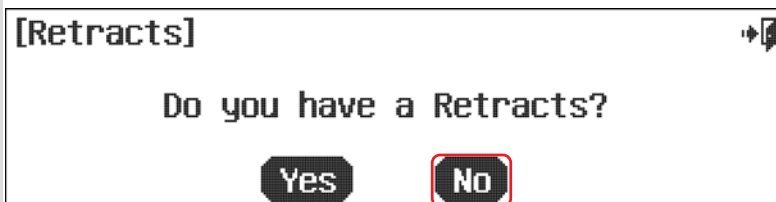

15. Spoiler? Press **No**.

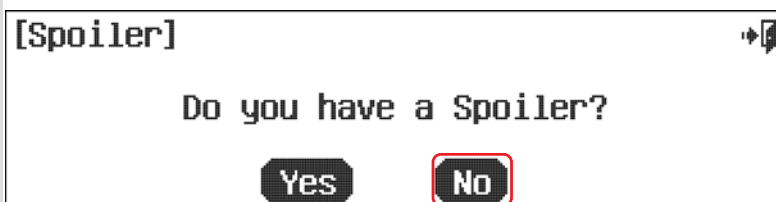

### System Programming Menu

16. The Aurora 9X's channel can be changed easily. If you want to change the channel, select the "No" icon. If there's no changes, select the "Yes" icon then it will go to the main screen.



17. If there are no channel changes, select the "SEL" icon and once you are done, press the "EXIT" icon in the upper right corner. If there is no need to add an extra function, press the "EXIT" icon, then it will go to the main screen.



18. Once you confirm if there is no correction in step 17, you can check the summary screen which includes all the features you have chosen. If there is a correction, select the icon and change, but if not, press the "EXIT" icon.



19. We are now back to the model select screen. Back out of it with the Exit icon at the upper right screen.

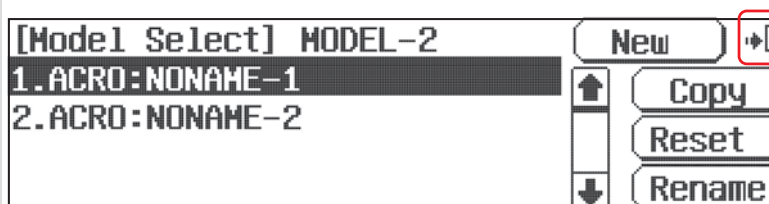

20. Back to the system menu page, and one more time, press the Exit icon.



21. At the Home page, turn off the transmitter and prepare your model to be set up.

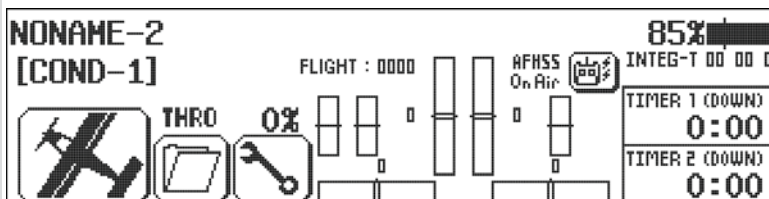

### Model Programming Menu

1. Turn on the transmitter, select **Yes** to transmit.

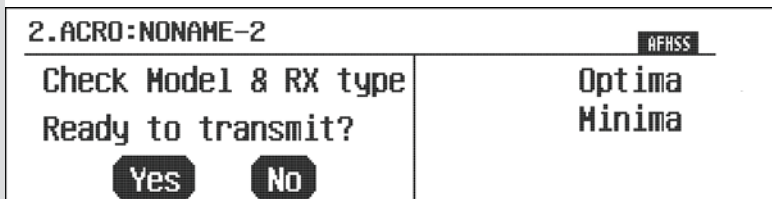

2. At the home page, let's select some model functions by pressing the plane icon at the lower left of the screen

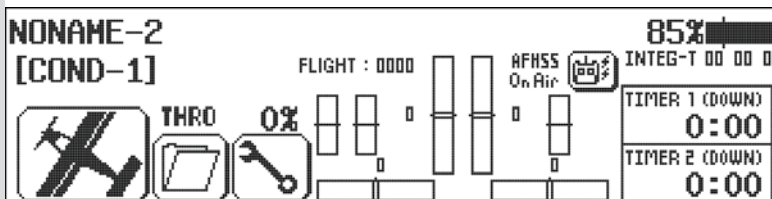

#### Throttle Lock

The Aurora 9X features a "throttle lock" function that can be activated when the transmitter is transmitting a signal. We encourage you to apply the throttle lock as a safety precaution against "accidental throttle application".

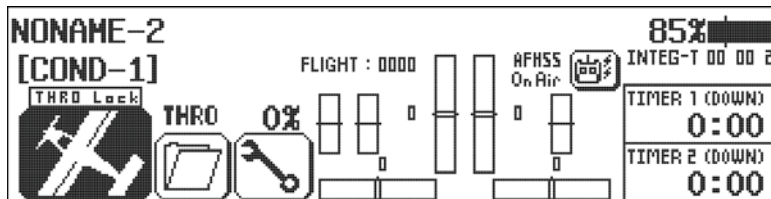

- a. Turn the throttle lock on and off from the home page by pressing the **Model** icon for two seconds. Throttle lock is confirmed when the "THRO Lock" icon is displayed.

3. This is the main screen. If you select 1/2 icon, you will find out all the setting menus. The Aurora 9X supports a variety of settings.



Now turn on power to your model. Within a moment, you should have control over your model with the transmitter.

4. Select **Reverse** from the model menu

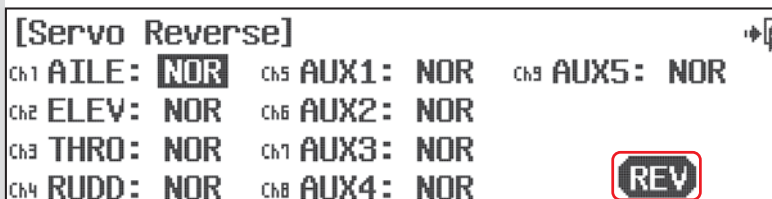

- a. Move your controls, are all the servos going in the correct direction? If not, select the channel to reverse, then press the **REV** icon.
- b. Press **Yes** when asked "Sure?"
- c. Do this until all servo throw directions are correct.
- d. Back up to the model menu by selecting the **Exit** icon.



## Model Programming Menu

5. Select **Sub-Trim** from the model menu

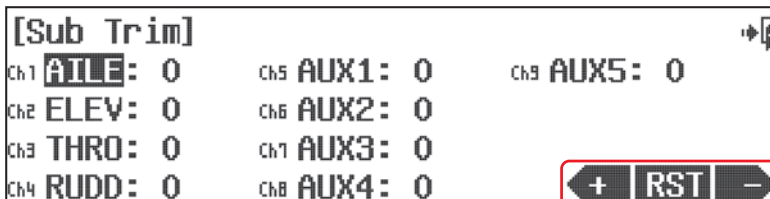

Your servo control arms should be as close to 90 degrees as possible, and the control surfaces as close to level as you can make them by adjusting the control linkages. Sometimes small adjustments must be made to “center” the control surface using the sub-trim function.

- Select the control/channel to adjust by pressing its icon.
- Using the **+ RST -** icon at the screens lower left corner, adjust a value as necessary by selecting the plus or minus icon. Select **RST** to bring the value back to zero if you wish. You should see the control surface moving as changes are made with the **+** or **-** icon.



**Sub trim is not the place to do a major adjustment. Any servo needing more than 40 points of movement should be adjusted by moving the control horn or adjusting the linkage.**

- Follow this procedure for any channels requiring sub-trim.
- When done, back up to the Model menu by selecting the **Exit** icon.



**Using the following functions is not mandatory. For the purpose of our quick set-up guide tutorial they will explain most of the fundamental programming techniques available in the Aurora 9X. We highly suggest you follow along with programming the EPA, dual and exponential rate functions. Doing so will teach you valuable lessons and the basics you need to get the most out of your Aurora 9X.**

6. Select **EPA** from the model menu

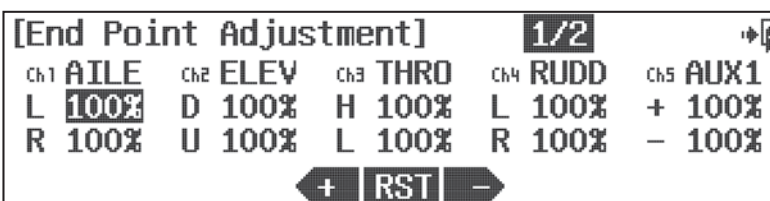

EPA stands for “end point adjustment”. With the EPA function you can set the servo arm travel distance by lengthening or limiting how far the arm moves. This function can help avoid binding or damaging the aircraft control surfaces, if set up properly.

In our example we will adjust the channel 1 aileron servo.

- Move the aileron control stick all the way to the left.  
The **R 100%** should be highlighted.
- Using the **+ RST -** icon set an appropriate value, more than 100% to increase the travel, or less than 100% to decrease the servo arm travel.
- Now move the aileron stick all the way to the right and set the travel value for the right side.
- Press the 100% value icon for any other channel you wish to set an EPA value for and follow steps a-c.
- When done, back up to the model menu by selecting the **Exit** icon.

### Model Programming Menu

7. Select **D/R&EXP** from the model menu

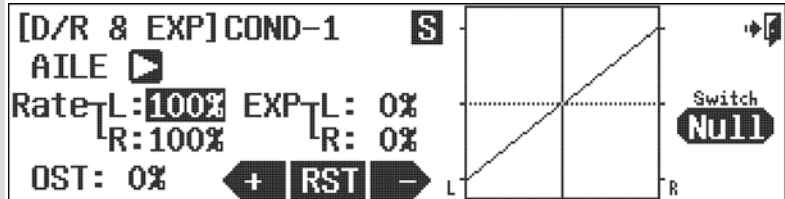

This screen holds two valuable functions, dual rates and exponential rates. Both functions are controlled at this screen.

Using the dual rate function allows you to select a switch that can change the travel rates or distance the servo arm moves a control surface.

We will first demonstrate dual rates, then show you how to program exponential rates.

A good example is that; even a very fast plane must take off and land at a relatively slow speed compared to how fast it may fly at full throttle. What is needed are two servo arm travel rates, dual rates, that we can program and then use a switch to select between these rates. When flying slow, full control movement is necessary, we will call this "high rates", and it is what you currently have set up based on the EPA values.

When flying very fast, small tiny movements of the control surface are required. We will call the small movements "low rates". Since we already have our high rates set up, let's set another rate, or servo arm travel distance that is smaller and will give us small control surface movement. This "low rate" can be activated by selecting a switch when you are flying.

Here is how to set up your aileron and elevator travel using the dual rate functions.

- a. The first control surface to change is the aileron; AILE pops up as the active function when entering this screen.
- b. Select "Rate" to highlight both R&L. This allows you to change both sides of the servo's travel rate at the same time.
- c. Move the aileron stick to the left, hold it there and press the - icon until you reach 75%.
- d. Now select a switch that we can throw while flying that will cut the aileron travel down to our 75% setting.
- e. Press the **NULL** icon to select the switch for our dual rate function.

8. At the intermediary switch screen press the **SEL** icon.

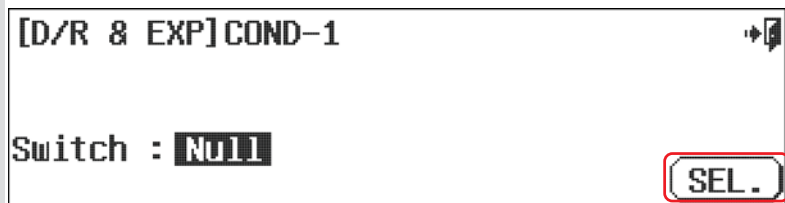

9. This is a map of the Aurora 9X switch layout. You can put the aileron dual rate function on any of the switches shown.

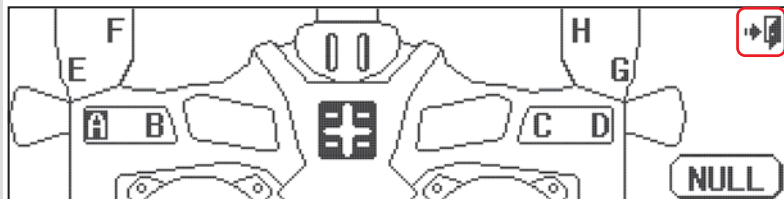

- a. Let's select switch "A".
- b. Select the **Exit** icon twice to back out.



## Model Programming Menu

10. Now we are back to the D/R&EXP screen.

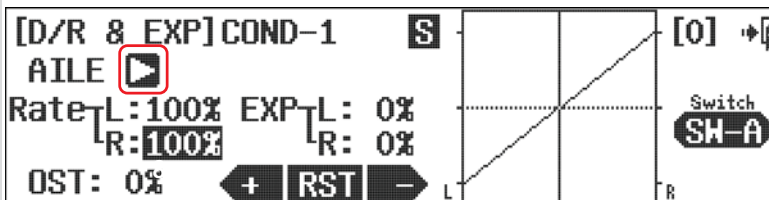

- a. Run through the same steps to select a dual rate for your elevator.  
We change to the elevator function by pressing the **arrow** icon to the right of AILE. Now it should read ELEV.

11. Follow steps 7 - 9 to program a 75% value for the elevator dual rate. Select the elevator dual rate to be active by assigning it on the same switch, "A" for the purpose of our demonstration. Be sure to put the 75% elevator value on the same switch "position" as our 75% aileron value.

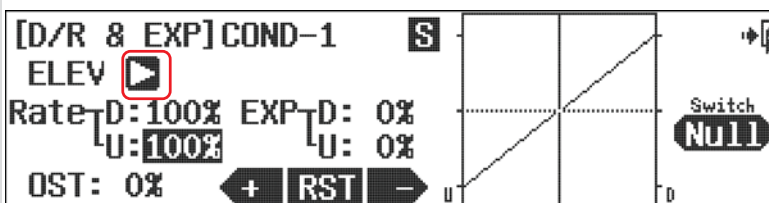

12. Using Exponential Rates

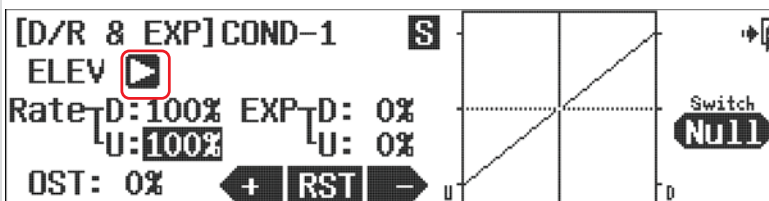

Now we can apply exponential rates to the aileron and elevator controls.

Using exponential rates allows you to shape the normally linear movement of a control surface. Our goal is to soften the middle of the stick around the center point for the "high rates". You will see this curve shaped on the graph displayed on the screen. Using negative expo values will help any pilot fly smoother on high rates, with greater control over their aircraft.

We will apply a -40% value to the expo setting for both the aileron and elevator high rates.

- a. Apply expo to your aileron control by selecting the AILE controls using the control select **arrow**.
- b. With the switch "A" in the position that gives us our high rate setting of 100% travel in dual rates, touch the **EXP 0%** icon to activate it.
- c. Now press **-** to apply a -40% value. See how the curve of the aileron servos movement changes to "soften" the center of the aileron control sticks travel.
- d. Change to the elevator again by pressing the **arrow** to the right of the AILE.
- e. Repeat steps to program our -40% EXPO value for the elevator high rates.

Now by throwing one switch, you can select to use dual rates and have expo on your elevator and ailerons.



For more advanced users, different expo and D/R values can be applied with individual switches and/or under multiple flight conditions.

Your plane should now be ready to fly. Do a range check and pre-flight, then go have fun!

### Quick Start Guide to Setting Up a Simple Heli

#### Section Three

To help you get the maximum benefit from your Aurora 9X, we will guide you through a simple set up of a common collective pitch 120CCPM heli. The operations shown during this exercise will help you learn many of the basic programming steps required by most of the Aurora 9X's features.

#### Channel assignments are:

- #1 Aileron or "roll" cyclic
- #2 Elevator or "pitch" cyclic
- #3 Throttle
- #4 Rudder or tail rotor pitch
- #5 Gyro function
- #6 Pitch Collective

After installing the servos and accessories in your heli, follow these steps to set it up.

### System Programming Menu

1. Turn on the transmitter; do not turn on the Heli.



Warning

For safety reasons during this set-up exercise on an electric powered heli please remove the blades and/or un-plug the motor from the speed control.

2. The first screen is the transmit option, select **No**.

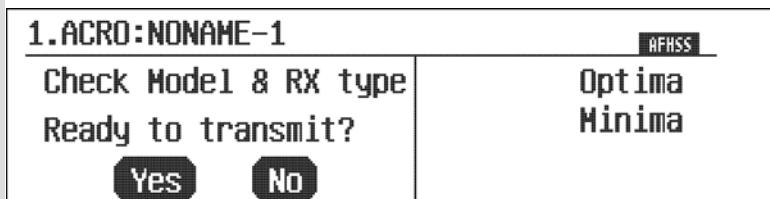

3. This is the home screen; select the **wrench** icon for the System menu.

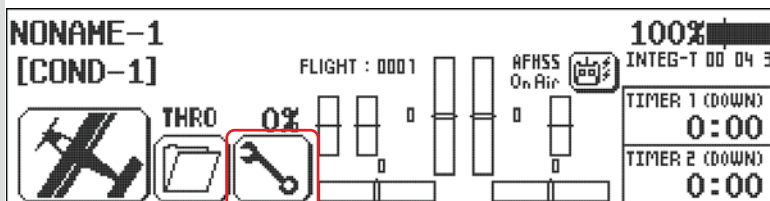

4. Note the System menu function choices, select, **MDL Sel.**

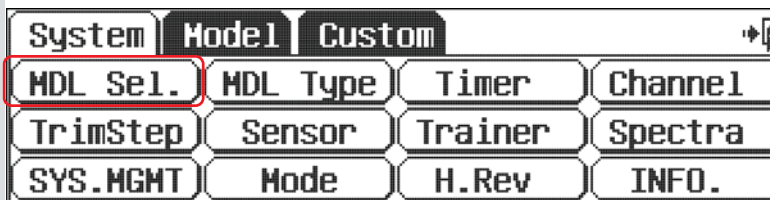

5. At the model selection screen press, **New**.

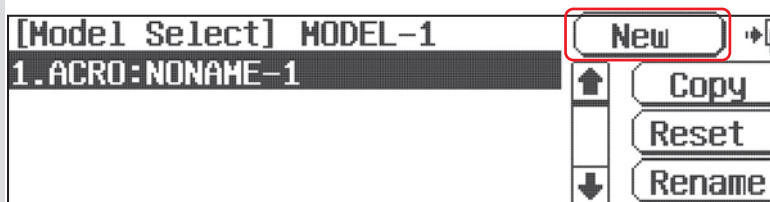

## System Programming Menu



We are programming a new model into the #2 model memory slot, not the model memory one slot. For the purpose of this exercise it will ensure a fresh model memory with no existing programming.

6. Select, **Yes** to confirm the selection of a new model.

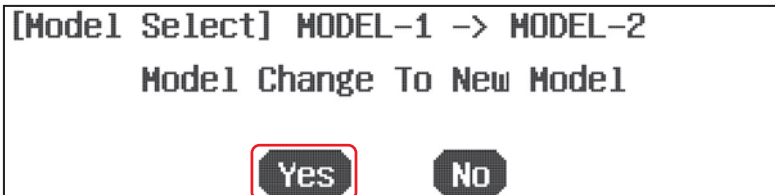

7. At the model naming menu, name your new model using the keyboard,

- a. Press **Shift** to see the other characters.
- b. When done press, **Enter**.



8. Here at the transmit option screen, press, **No**. We do not wish to transmit yet.

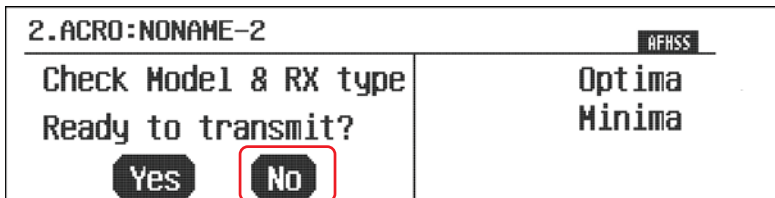

9. Next you are prompted to the model type screen where we select **HELI** (the heli icon on the right).



10. Select change to HELI, **Yes** at the model type change confirmation screen.



11. Here is the screen that will tell the transmitter what kind of swash type your heli uses.



### System Programming Menu



There is a 1/2 icon in the upper right of the screen. This means there are two pages in this menu. Touch the 1/2 icon and note the second screen has even more swash type selections. Many function menus will have more than one screen of options. Check for the 1/2 icon as you program your heli into the radio.

a. For our sample heli, you must select what swash type your heli uses. Most will select 120 or 90 degree CCPM swash type. Consult your heli manual to find out what swash type your heli uses. Then press the SET icon.



Depending on what you select in this, and for the following choices of this menu, the radio will automatically optimize the functions for your choices.

12. Governor? Press **No**.

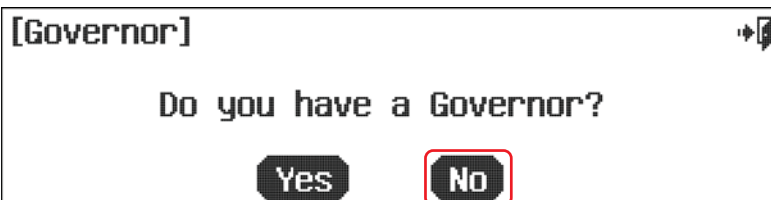

13. Needle control? Press **No**.

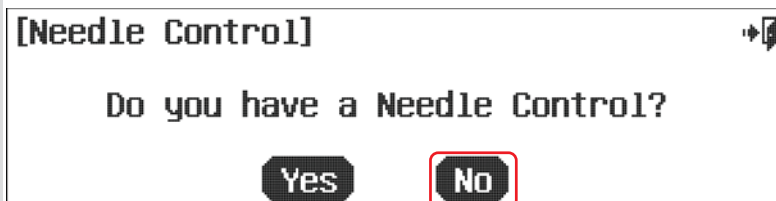

14. Ok here are the channel assignments, the radio has selected for you. They should be appropriate, select **Yes**.

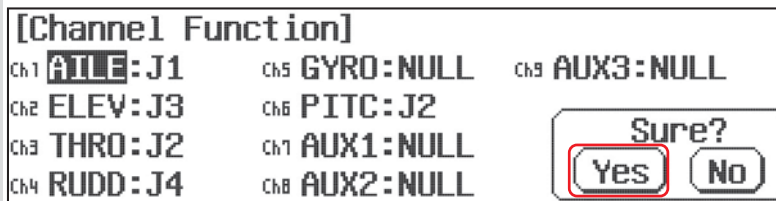

15. At the Home page, turn off the transmitter and prepare your model to be set up.

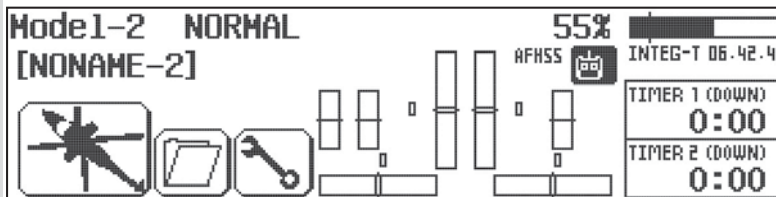

## Model Programming Menu

- Now turn on the transmitter, select **Yes** to transmit.

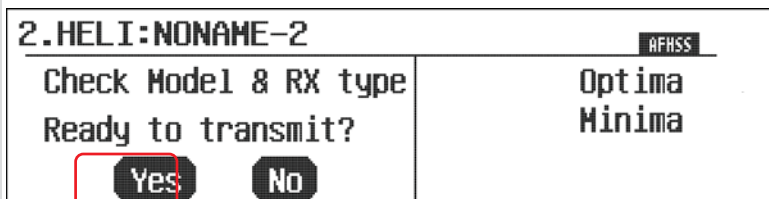

### Throttle Lock

The Aurora 9X features a "throttle lock" function that can be activated when the transmitter is transmitting a signal. We encourage you to apply the throttle lock as a safety precaution against "accidental throttle application".

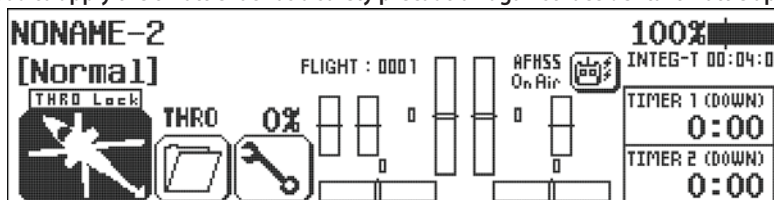

- Turn the throttle lock on and off from the home page by pressing the **Model** icon for two seconds. Throttle lock is confirmed when the "THRO Lock" icon is displayed.

- At the home page, let's select some model functions by pressing the **heli** icon at the lower left of the screen.

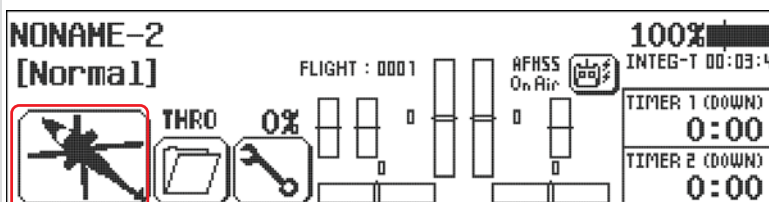

- The Model menu is one of those "two page" screens, note the **1/2** icon. Here are all the functions the Aurora 9X can apply to our rather simple selected model.



Now turn on the power to your model. Within a moment, you should have control over your model with the transmitter.



If any of your model's controls bind and stall the servo, turn off the model and correct the situation. Take the control horns off and reposition them with the model turned back on, then adjust the linkage accordingly.

We are going to use the following functions to set up our model:

- Reverse** To correct any servo travel direction issues
- Sub-Trim** To trim-out any small control surface deflection issues
- EPA** This will set an end point to the servos throw in both directions
- Gyro** Program the gyro sensitivity and other functions
- Pitch Curve** Fine tune the collective curve for the best performance
- Throttle Curve** Fine tune the throttle curve for the best performance
- D/R&EXP** Set a dual rate and/or exponential function

### Model Programming Menu



Note

Sure there are many more functions you may wish to try, but for our example please follow along and do the ones we suggest for your first model set-up.

4. Select **Reverse** from the model menu



- Move your controls, are all the servos going in the correct direction? If not, select the channel to reverse, then press the **REV** icon.
- Press **Yes** when asked "Sure?"
- Do this until all servo throws are correct.
- Back up to the model menu by selecting the **Exit** icon.

5. Select **Sub-Trim** from the model menu

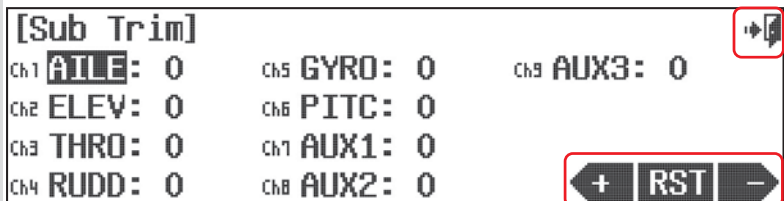

Generally with a few exceptions, most notably the collective servo in a "normal" curve, and the throttle servo in a glow or gas aircraft, your servo control arms should be as close to 90 degrees as possible, and the control surfaces as close to level as you can make them by adjusting the control linkages. Sometimes small adjustments must be made to "center" the control surface using the sub-trim function.

- Select the control/channel to adjust by pressing the appropriate icon.
- Using the **+ RST -** icon at the screen's lower right corner, adjust a value by selecting the plus or minus icon. Select **RST** to bring the value back to zero if you wish. You should see the control surface moving as changes are made with the **+ or -** icon.



Caution

Sub trim is not the place to do a major adjustment. Any servo needing more than 40 points of movement should be adjusted by moving the control horn or adjusting the linkage.

- Follow this procedure for any channels requiring sub-trim.
- When done, back up to the Model menu by selecting the **Exit** icon.

6. Select **EPA** from the model menu

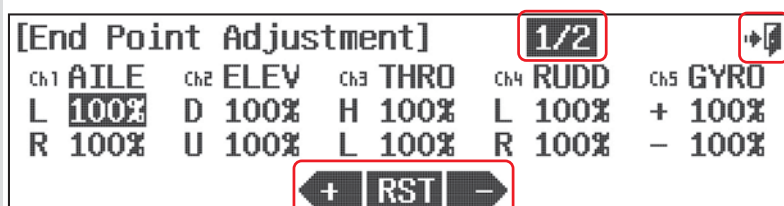

EPA stands for "end point adjustment". With the EPA function you can set the servo arm travel distance by lengthening or limiting how far the arm moves. This function can help avoid binding or damaging your heli control surfaces, if set up properly. In our example we will adjust the channel six pitch function to help you set up your collective end points.



## Model Programming Menu



Warning

When making the following fundamental adjustments, the blades should be on the heli, and a pitch adjustment device showing the degrees of blade pitch should be used to set the collective end points correctly according to the heli manufacturer's specs. Be sure to disconnect the motor on electric helis to avoid injury.

- a. Press the **1/2** icon to access page two of the EPA adjustment menu.
- b. Move the throttle up and down to see the highlighted H and L value change. With the stick at full throttle, (all the up) we want full (up) collective movement. The H 100% should be highlighted.



Caution

It is at this point it may become clear that your collective linkages may need to be physically adjusted to achieve the heli manufacturer's negative and positive blade pitch specifications.

- c. Using the **+RST-** icon set an appropriate value, more than 100% to increase the travel, or less than 100% to decrease the servo arm travel.
- d. Now move the throttle stick all the way down to the low throttle/low collective point and set the value for low collective.
- e. Repeat these steps for all the channels you wish to set an EPA value for.



Tip

EPA is a handy function to adjust the high and low throttle linkage points on glow helis.

- f. When done, back up to the model menu by selecting the **Exit** icon.

### 7. Gyro Functions

Because there are so many types of gyros and gyro functions, please refer to the complete description of the Aurora 9X's heli gyro functionality. Come back here when you are done with the gyro function.

### 8. Pitch Curve and Throttle Curve Adjustments

Setting pitch and throttle curve points to maximize your helis performance can be a lengthy process requiring time, patience and some experience.

A pre-set linear curve is already programmed into the radio and you may not need to adjust the curves to fly your heli successfully.

### 9. Select the **D/R&EXP** from the model menu

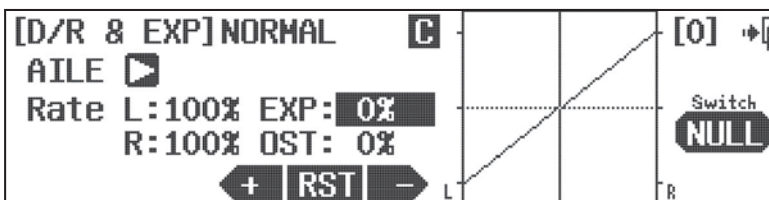

This screen holds both the dual rates and exponential rate menus.



### Model Programming Menu

#### Using Exponential Rates

Using exponential rates allows you to shape the normally linear movement of a control surface. Your goal is to soften the middle of the stick around the center point of the cyclic, your aileron or “roll” and elevator or “pitch” functions. You will see this curve shaped on the graph displayed on the screen. Using negative expo values will help any pilot fly smoother, with greater control over their aircraft.

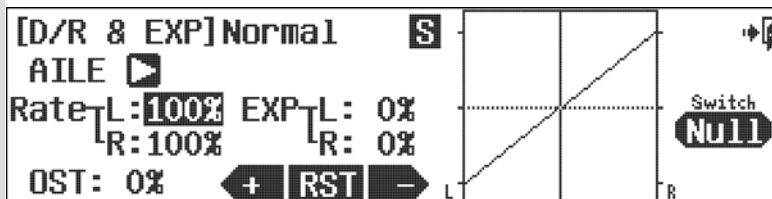

a. Touch the **EXP 0%** icon to activate it.

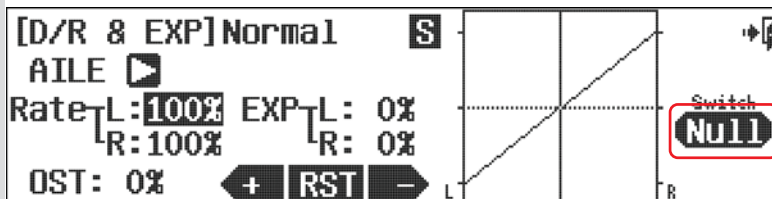

b. Now press **-** to apply a -40% value. See how the curve of the aileron or “roll” cyclic servo’s movement changes to “soften” the center of the aileron control sticks travel.  
c. Press the **NULL** icon to select the switch for our roll cyclic expo rate function.

10. At the intermediary switch screen press the **SEL.** icon.



11. This is a map of the Aurora 9X switch layout. You can put the AILE expo select switch on any of the switches shown. then press **Exit** icon.

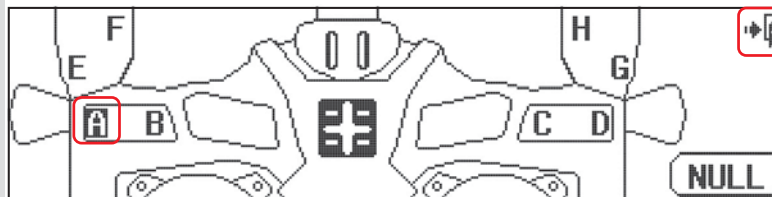

a. Let’s select switch “A”.  
b. Select the **Exit** icon twice to back out.

## Model Programming Menu

12. Back at the D/R&EXP screen

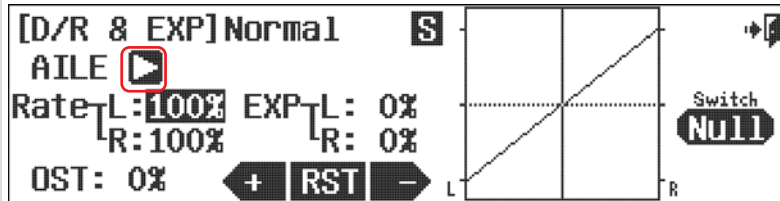

- Change to the elevator or “pitch” cyclic servo by pressing the **arrow** to the right of AILE.
- Now program our -40% EXPO value for the elevator or “pitch” cyclic.
- Press the **NULL** icon to select the switch for our dual rate function.
- Repeat steps 30 and 31 to place the function select on switch A.  
Make sure your switch position is correct before entering a rate value.

What you should have is the ability to select full cyclic expo on or off with the A switch.



Note

For more advanced users, different expo and D/R values can be applied under different flight conditions.

Your heli should now be ready to fly. Do a range check and pre-flight, then go have fun!

This is the end of the heli quick set-up guide. It will not be the end of your Aurora 9X heli programming education. What you know is the bare minimum of the Aurora 9X heli programming, just enough to get you in the air.

### System Menu

There are two primary menus in the Aurora 9X programming. The System function menu and the Model function menu. The first we will explore is the System menu.



If you have not already programmed a model with the preceding quick start guide, we encourage you to do so before tackling the System and Model programming sections of the manual.

The following features are described in the system menu.

<p><b>Model Select menu</b></p> <p><b>MDL Type</b></p> <p><b>Timer</b></p> <p><b>Channel</b></p> <p><b>TrimStep</b></p> <p><b>Sensor</b></p> <p><b>Trainer</b></p> <p><b>Spectra</b></p> <p><b>SYS.MGMT</b></p> <p><b>MODE</b></p> <p><b>H.Rev</b></p> <p><b>Info</b></p>	<p>Create a new model</p> <p>Select an existing model</p> <p>Copy one model's data into a new model memory slot</p> <p>Reset the model memory to factory default settings</p> <p>Rename a model</p> <p>Model type menu, ACRO, GLID or HELI.</p> <p>Menu for Timer 1, 2 and the Integral timer.</p> <p>Model control channel assignment menu.</p> <p>Size adjustment menu for the trim steps.</p> <p>Telemetry menu appearing while in 2.4GHz mode only.</p> <p>Trainer option menu.</p> <p>RX Type (Optima, Minima, SLT)</p> <p>Backlight option</p> <p>: Touch lock option</p> <p>: Touch response option</p> <p>: Warning option</p> <p>Stick mode option menu.</p> <p>Hardware reverse option</p> <p>Transmitter ID information.</p>
--	---

1. Turn on the transmitter.

2. You are asked if you wish the radio to transmit a signal, press **No** for now.

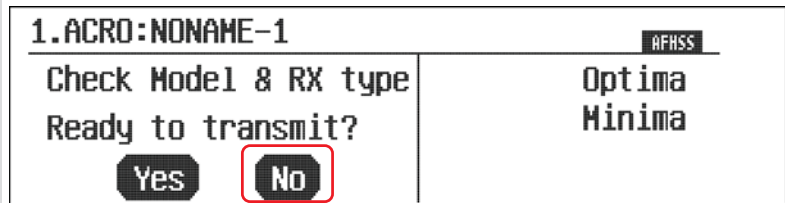

If you want to transmit, at any point in the programming process, turn off the transmitter and then turn it back on, you will be asked in the first screen if you wish to transmit, then press **Yes**.

3. To access the system menu from the home screen select the **wrench** icon.

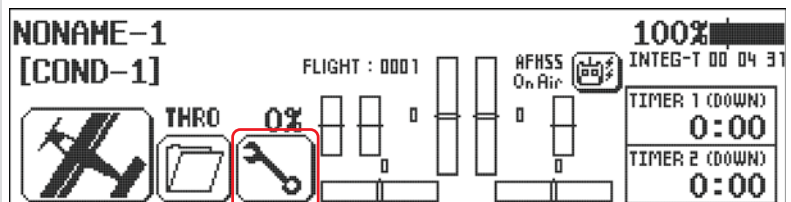

## System Menu

These are all the features of the system menu associated with the active model. Full explanations of their function can be found in the following text.

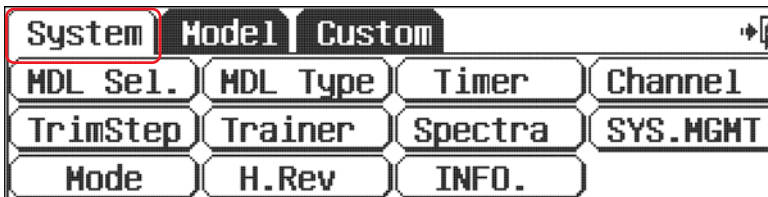

Depending on the signal modulation being used, the home screen will have slightly different functions.

## Model Select Menu

From the MDL Sel. menu you can:

1. Create a new model.
2. Select an existing model to use.
3. Copy one model's data into a fresh model memory slot.
4. Reset the model memory to factory default settings.
5. Rename a model.

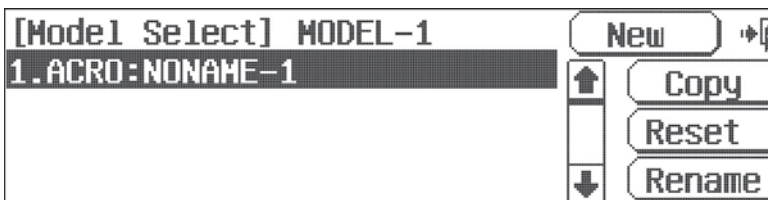

### 1. Create a new model

This function is one of the longest to explain and also one of the most exciting to perform as this menu provides the "base" for all future programming for the selected model.

Because this menu branches out in so many directions depending on the airframe choices you will select for your model, we want to print it just once. Please read and follow the Quick Set-up guide for either heli or airplane/glider and follow the directions there. After you have done this once, the menu will be "laid out" in front of you in a way so that it is almost impossible to make a mistake.

### 2. Select an existing model

- a. Use the scroll bar to find the model you wish to load and press the **model name**.
- b. Press **Select**.

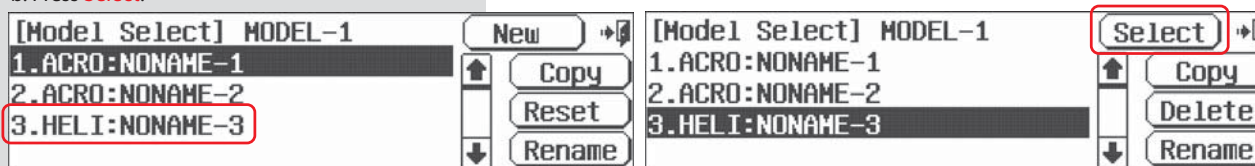

- c. You are asked to ok the change, by pressing Yes or No, press **Yes**.
- d. Next when directed to the transmit Yes - No screen, press, **No**. We don't need to transmit yet. Now we are back to the home screen.

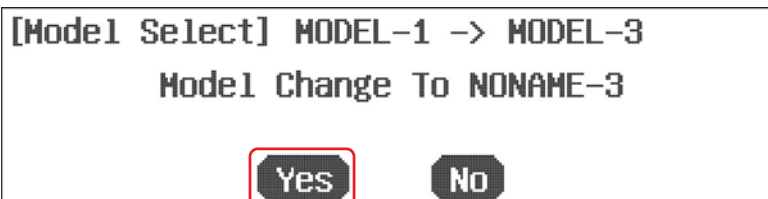

### Model Select Menu

#### 3. Copy one model's data into a new model memory slot

a. From the System menu select **MDL Sel.**

b. Select the model you wish to copy from the list of models on the left. Select, **Copy**.

c. Press, **New**.

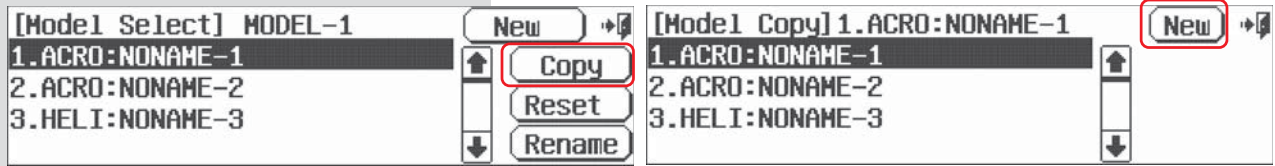

e. You are asked if you wish the selected model to be copied to the next free model memory slot.

Press, **Yes**. Note the next memory slot has the same name and programming as the selected model.

You may want to change the model name using step 5, the model "rename" feature in this section.

f. Press the **Exit** when you are done.

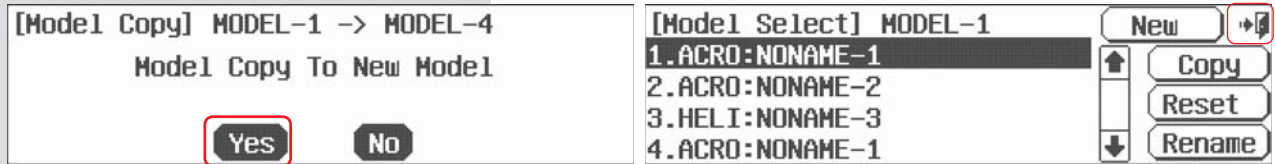

#### 4. Reset the active model memory slot to factory default settings

a. From the system menu select **MDL Sel.**

b. Select the model you wish to delete from the list of models on the left.

c. Press **Delete**.

d. Press **Yes** to confirm the deletion of the active model's programming.

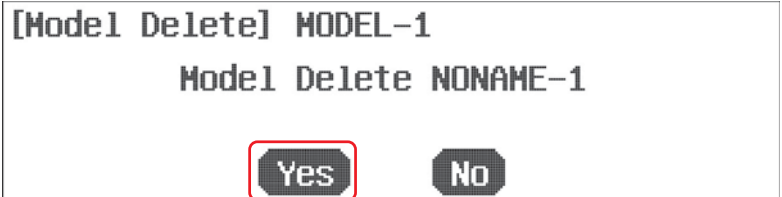

e. Now we are back at the model select menu, press the **Exit** to enter the system menu.



**Note** You can't delete the active model.

#### 5. Rename a model

a. From the system menu select **MDL Sel.**

b. **Select** the model you wish to **rename** from the list of models on the left.

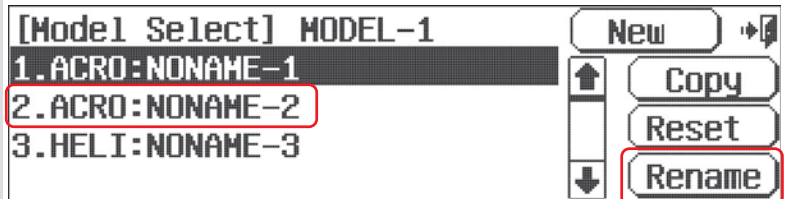

c. Rename it using the keyboard screen, when done press, **Enter**.



d. Now back at the model select screen, press the **Exit** icon to return to the system menu.



## Model Type Menu

The model type screen defines the features of the active model. These are the features we told the radio our model had during the “create a new model” process plus all the default features. Here we define all the choices you have while setting up your aircraft in the Aurora 9X.

There are three types of aircraft “model type” menus,

ACRO		For all fixed wing, glow, gas and some electric powered models.
GLID		For all pure gliders and some electric powered airframes.
HELI		All helicopters will use the HELI menu.

We will first define ACRO:

### Model Type ACRO Menu Programming

a. From the System menu select MDL Type.

b. Press the Model icon on the left.



c. Select ACRO.

d. Confirm the change to ACRO, press Yes.

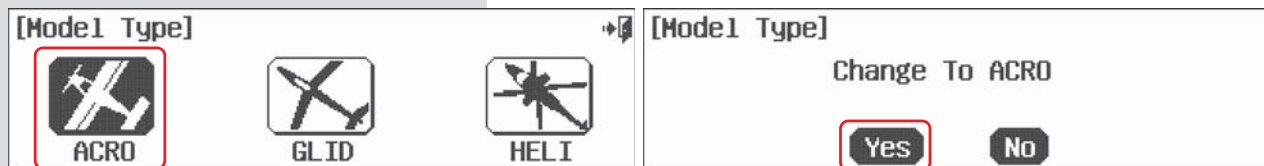

e. There are two screens of wing type choices. Press the 1/2 icon to see the second screen of wing types.

f. The wing type menu contains these choices. Select the choice for your airframe and press, SET.

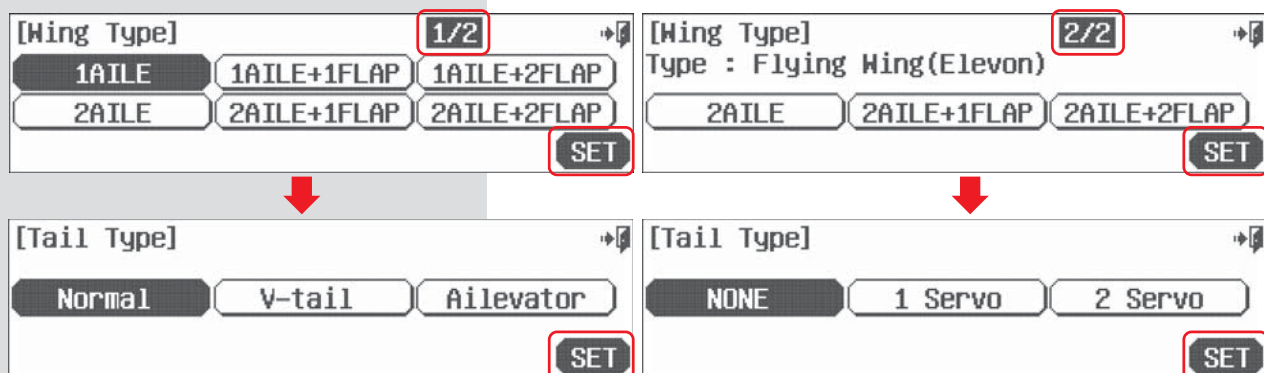

g. Select your airframe tail type icon

h. Press SET.

g. Select your flying wing tail type icon

h. Press SET.



### Model Type Menu

i. Select the **Single** or **Dual** engine icon.  
j. Press **SET**.

[Engine Type] →

k. Does your model have retracts?  
Press **Yes** or **No**.

[Retracts] →

Do you have a Retracts?



Note

If you select, **Yes** to the retract question, "Gear" will be associated with a channel shown in the channel function menu. You will have to associate a control or switch to the "Gear" function.

l. Does your model have Spoiler?  
Press **Yes** or **No**.

[Spoiler] →

Do you have a Spoiler?

n. This is the Channel Function menu.  
It shows you what transmitter controls operate the different aircraft controls.  
For now, press **Yes**.

[Channel Function]

Ch1 <b>AIL1: J4</b>	Ch5 <b>AIL2: J4</b>	Ch9 <b>AUX4: NULL</b>
Ch2 <b>ELEV: J2</b>	Ch6 <b>AUX1: NULL</b>	
Ch3 <b>THRO: J3</b>	Ch7 <b>AUX2: NULL</b>	
Ch4 <b>RUDD: J1</b>	Ch8 <b>AUX3: NULL</b>	

o. Press the **Exit** icon to return to the model type menu.

[Model Type] →

Model	Wing	Tail
	<input type="button" value="1AILE"/>	<input type="button" value="Normal"/>
	<input type="button" value="NONE"/>	

This is the end of the acro model type menu.  
For a complete description of the glid and heli model type menu, refer to the following sections.



## Model Type Menu

This is the model type menu for most gliders and some electric airplane applications.

### Model Type Menu Programming

a. From the System menu select **MDL Type**.

b. Press the **Model** icon on the left.



c. Select **GLID**.

d. Confirm the change to GLID, press **Yes**.



e. There are two screens of wing type choices. Press the **1/2** icon to see the second screen of wing types.

f. The wing type menu contains these choices. Select the choice for your airframe and press, **SET**.

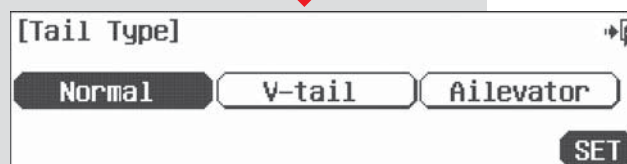

g. Select your airframe tail type icon.

h. Press **SET**.

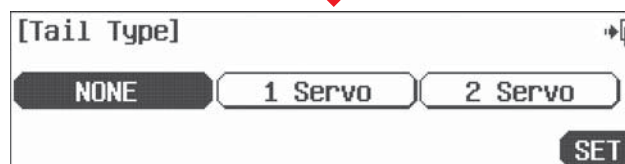

g. Select your flying wing tail type icon.

h. Press **SET**.

i. Select **Yes** if you need a motor control channel function.

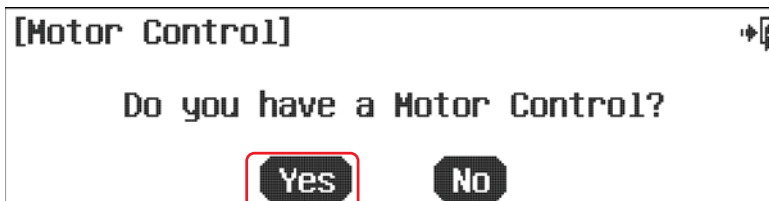

j. Does your model have retracts?  
Press **Yes** or **No**.

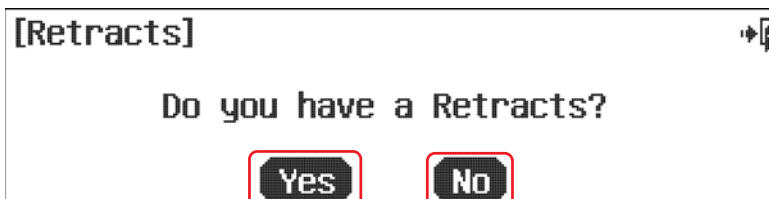

### Model Type Menu

k. Does your model have Spoiler?  
Press **Yes** or **No**.

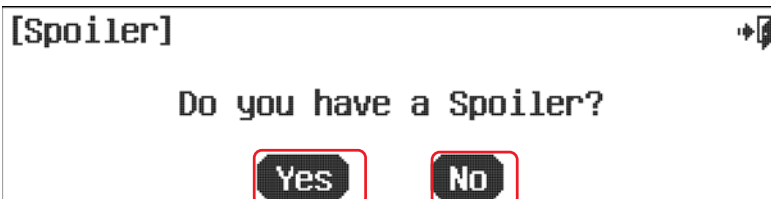

l. This is the Channel Function Menu.  
It shows you what transmitter controls operate the different aircraft controls.



m. Press the **Exit** icon twice, to return to the model type menu screen.



### Model Type HELI Menu Programming

Use the following information to set up your heli features in the model type menu.

a. Press the **Model** icon.



b. Select **HELI**.



c. Confirm the change to HELI, Press **Yes**.



## Model Type Menu

d. There are two screens of swash type choices. Press the **1/2** icon to see the second screen of options.

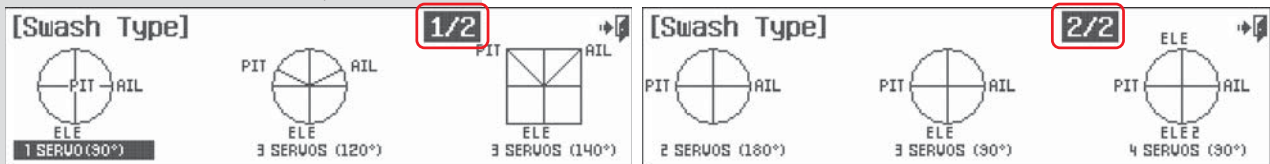

e. The swash type menu contains these choices. Press the choice for your heli.

f. Does your heli have a Governor?  
Select **Yes** or **No**.

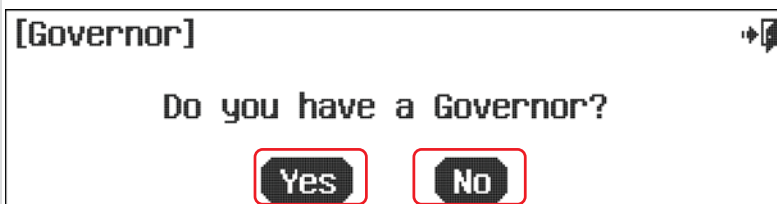

g. Does your model have a needle control?  
Press **Yes** or **No**.

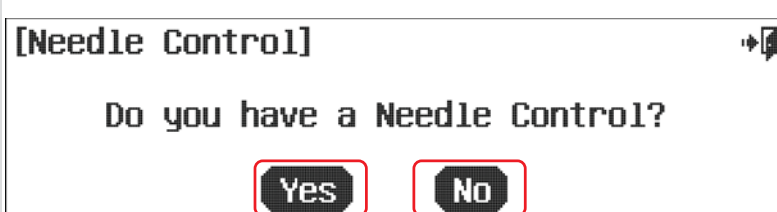

h. This is the Channel Function Menu.  
It shows you what transmitter controls operate the different aircraft controls.  
For now, press **Yes**.



i. Press the **Exit** icon twice, to return to the model type menu screen.



### Timer Menu

The AURORA 9X has three timers and one counter. Also, it supports two built-in timers which display total time and flight time.

#### Timer 1 and Timer 2 Set-up

- You choose to activate timer 1 and/or timer 2.
- Select the time value.
- Select a "count up" or "count down" format.
- Select the timer 1 and timer 2 activation switch.

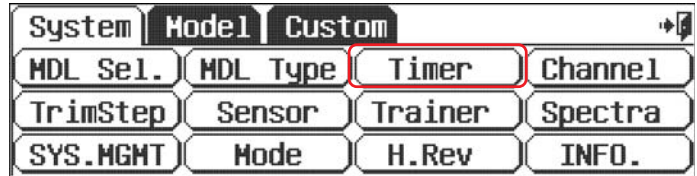

- Access the timer menu from the system menu **Timer**, or Press the timer 1 or timer 2 icon on the home page.
- Press **ACT** to activate the timer function.

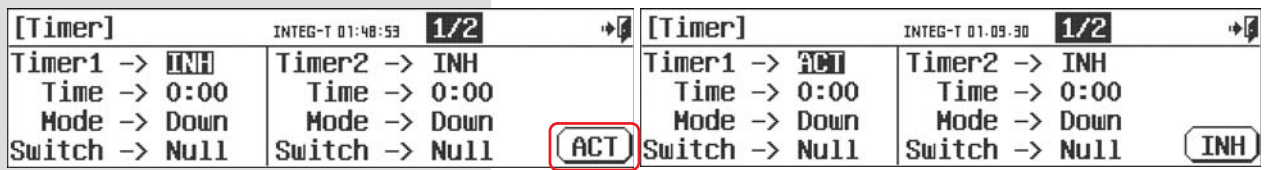

- Press **0:00** to set the time value with the up/down **RST** icons.
- The default counting mode is DOWN, select UP if you want this changed to UP.

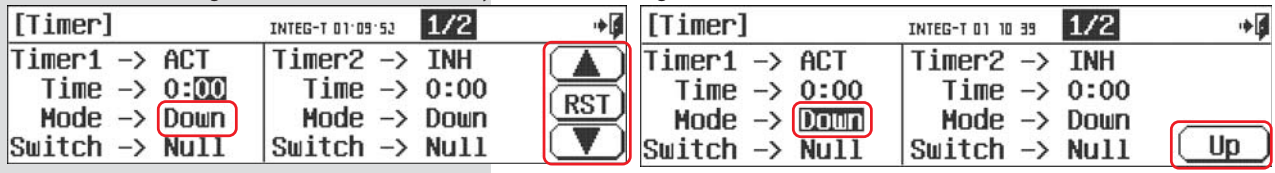

- Select the **NULL** icon to transfer the timer function to a switch, or the throttle.
- At the intermediary switch screen press the **SEL.** Icon.

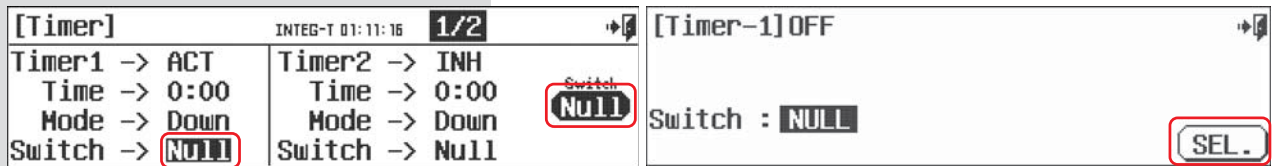

- This is a map of the Aurora 9X switch layout.

You can put the timer function on any of these switches, or the throttle.

We will show examples for doing both.

- Let's select switch **F**.

- Select the **Exit** icon to "back" out of this screen.

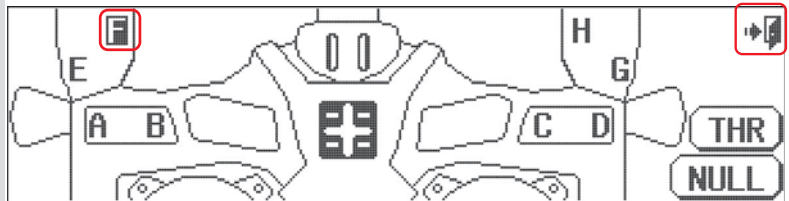

- Some switches are two, and some are three position switches.
- Switch H is a "dead man" toggle switch that is primarily used for training and/or throttle cut purposes.

- Flip switch **F** back and forth, note the switch icon changing.

Depending on your preference you can select the "up" position or the "down" position to be on or off.

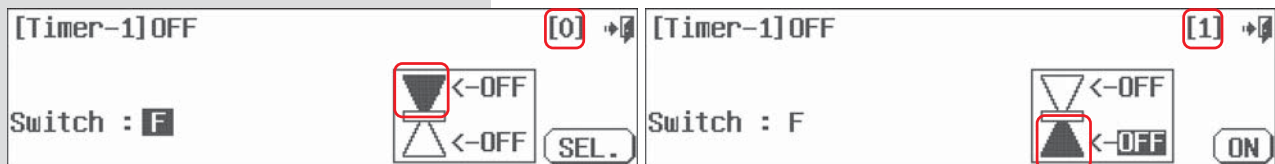

## Timer Menu

- k. Flip switch **F** towards you. The lower position of the icon should be highlighted. Press the **OFF** icon.
- l. Now press the **ON** icon.
- m. Your timer is now active when the switch **F** is toggled toward you.
- n. Back out, by pressing the **Exit** icon.

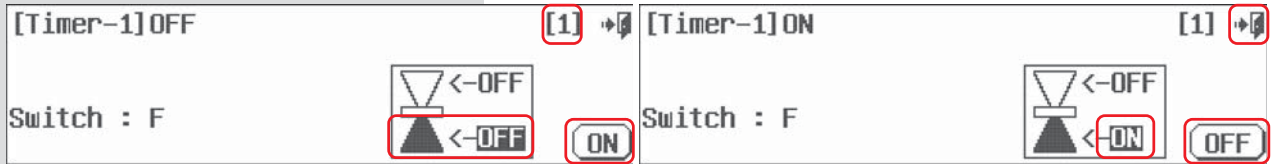

- To select the throttle as Timer 2's activation trigger
- o. Follow steps a-f in this section, to activate timer 2.

- p. At the switch menu, select the **THR** icon
- q. Press the **Exit** to back out.

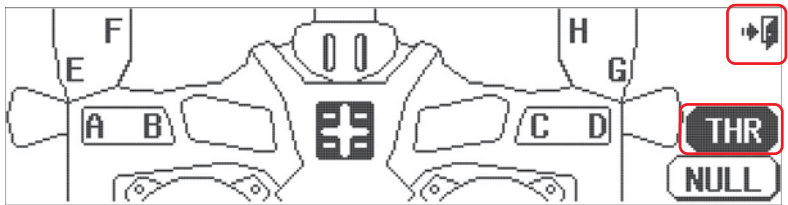

- r. Press the top **OFF** icon in the little box.
- s. Press the **ON** icon.

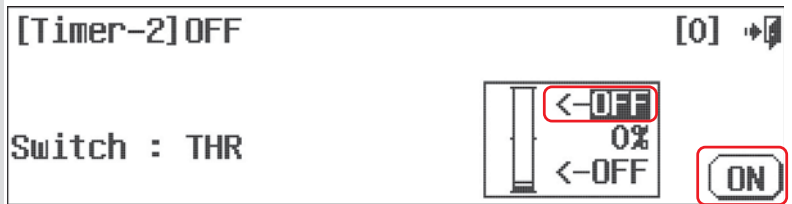

- t. Press the **0%** icon.
- u. Move the throttle stick to the position you want the timer to start. We suggest a position just above idle. Note the bar move up and down the vertical graph, press **SET**.

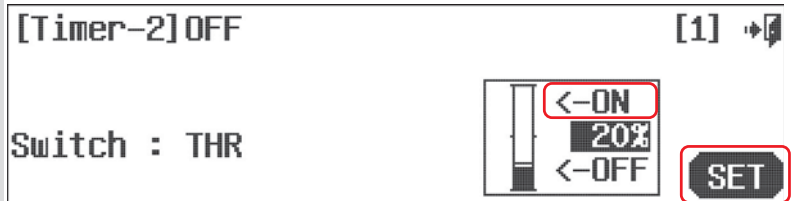

## Flight Counter

Flight counter is a function that can count the number of flights.

- a. Click 1/2 icon. It will go on to the second page.

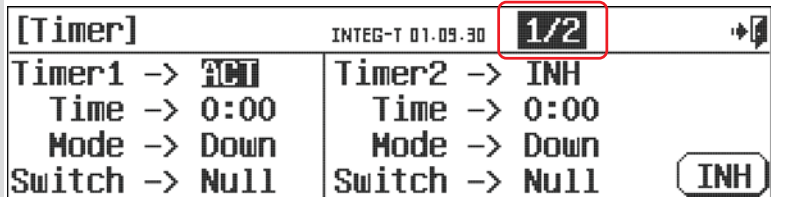

- b. It should be activated to the initial value

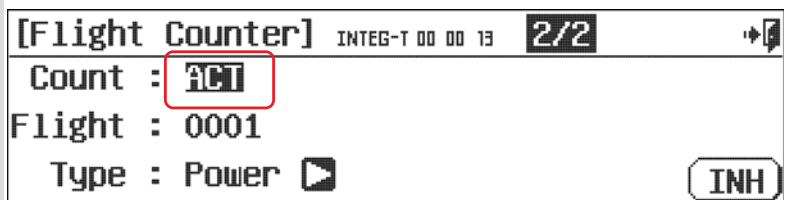

### Timer Menu

c. Using the Up / Down RST icon can be configured to the desired counter

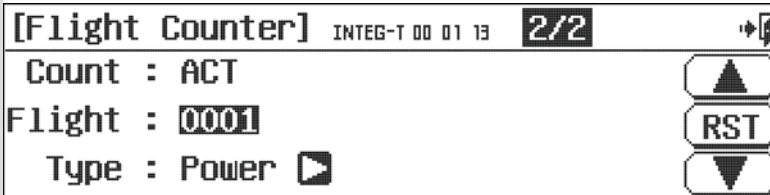

d. You can set flight counter checking method. (The default has been the power switch on & off.)

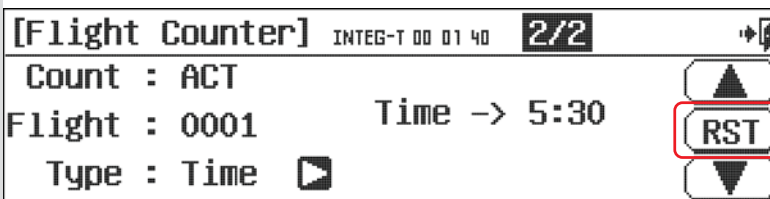

e. The Up / Down RST icon can be selected as you prefer.

f. You can also choose the flight checking method by switch.

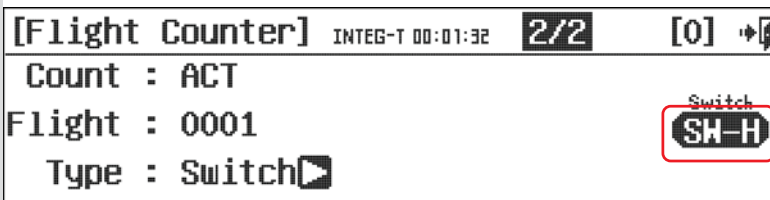

g. The Aurora 9X shows switch which can link with timer. It can also link with throttle stick. (the default has been SW H.)

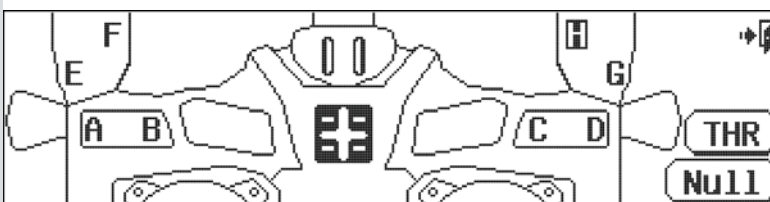

h. Check if there is a "k" in the Timer Menu.

We now have selected the throttle to activate the #2 timer when the throttle is "up".  
 When the throttle is back at idle, the timer is not running.

### The Integral Timer

Located on the home page, the integral timer displays the "total time on".

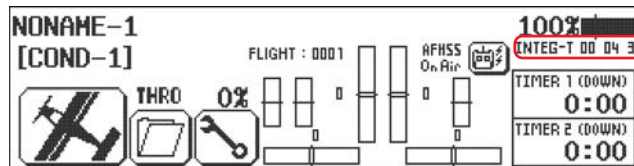

To reset the integral timer back to 00:00:00

- Select the **Timer** icon from the system menu.
- Press the INTEG-T XX:XX:XX "time" icon at the upper right of the screen
- Select **RST** to reset the Integral timer to zero.
- Press the **Exit** to return to the system menu.





## Channel Menu

This screen displays the controls associated with their respective channels. Using the channel select functions allows a high level of creativity in the way you can custom program the Aurora 9X.

a. Select Channel from the system menu.

b. Press the function (should be, **AUX5**) to the right of ch. 9.

c. Press, **SEL**.



d. Press Needle.

e. Press **SET**.



Note

This menu has two screens. Note the 1/2 icon, press it to see screen two.

f. Back at the Channel Function screen, press the NULL icon at ch. 9 Need : **NULL**

g. Press, **SEL**.

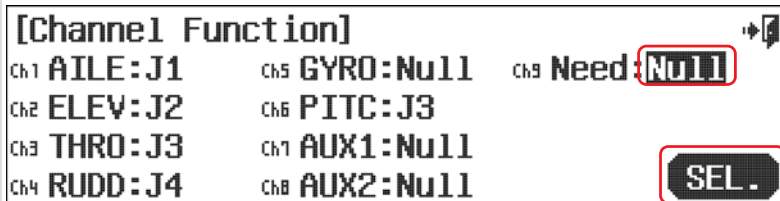

h. Select a controller for the Needle function, perhaps the throttle. The J3 stick is used to ricken or lean the needle control as the throttle is moved? Press **J3**.

i. Press, **SET**.

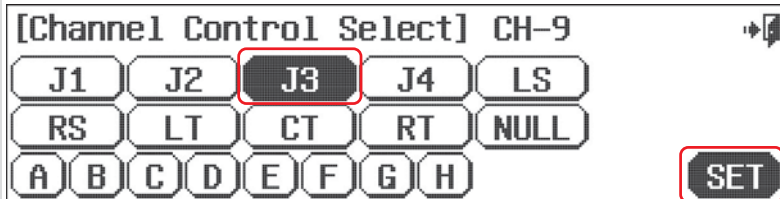

j. Touch the **Exit** icon to go back to the system menu.

This level of choice defines the Aurora 9X's "open" software architecture. Experiment to find what you can do here, as there is no "right" or "wrong" way to do it.



### Trimstep

At the Trim Step screen we can change the size of each step the digital trims move with one “beep”, or “movement step value” of a digital switch.

a. Press the **TrimStep** icon from the system menu.



b. To increase or decrease the size of the trim step, press the **number** value to the right of the trim you wish to change.

c. Change the value with the **+ RST -** icon.

d. Exit when done by selecting the **Exit** icon.



Note

The Trim Step value can be selected from 1 to 200. The default is 12.

## Sensor Menu

When using the Optima receiver, the following information can be relayed between the receiver and Tx.

a. Select sensor from the system menu.

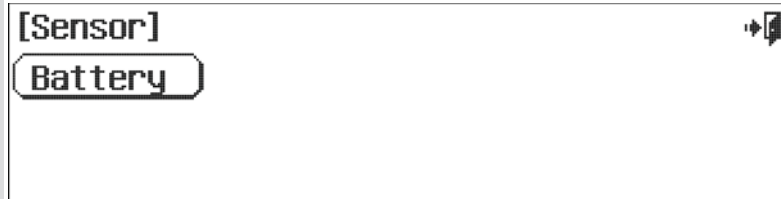

b. On the first page, you can set the maximum and minimum values and low voltage warning of the receiver battery in both directions.

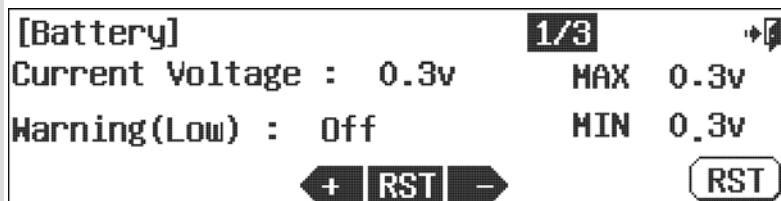

c. On the second page, you can set the maximum and minimum values, voltage sensor setting, and warning setting when you use the HTS-Sensor station (Blue, Advance).



d. On the third page, you can set the maximum and minimum values, current sensor setting, and warning setting when you use the HTS-Sensor station (Blue, Advance).



e. Press the Exit icon.

### HTS-SS Advance sensor station and the Aurora 9X

The Aurora 9X transmitter is designed to show a variety of information in real time on the screen of the transmitter when connected to the HTS-SS Advance sensor station accessory.



Note

Note the following directions to interface the HTS-SS Advance and the Aurora 9X transmitter.

### Sensor Menu

a. Once the HTS-SS advance is connected to the Aurora 9X properly, select "Sensor" from the system

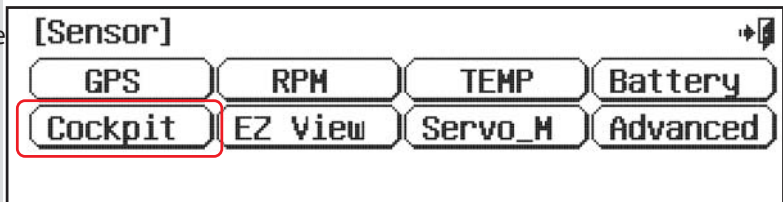

b. You can change the settings for each sensor.

c. In the data screen, there is a combination mode which can see a variety data.

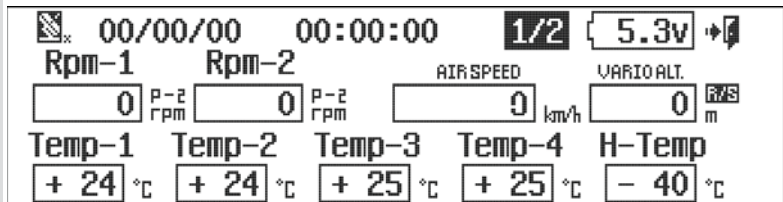

d. There is a special view mode in the data screen. Using this mode, you can customize the data to your preferences.

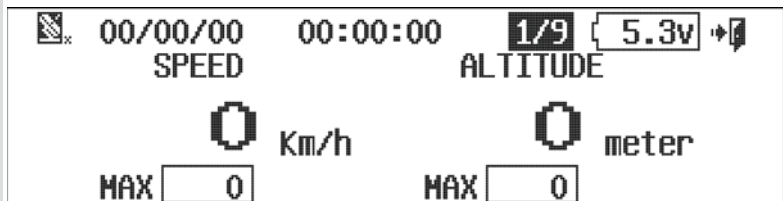

e. Press Exit icon.

### Set-up for the HTS-SS Nitro and Blue sensor stations

a. When the HTS-SS Blue is connected to the Aurora 9X properly, select "Sensor" from the system menu.

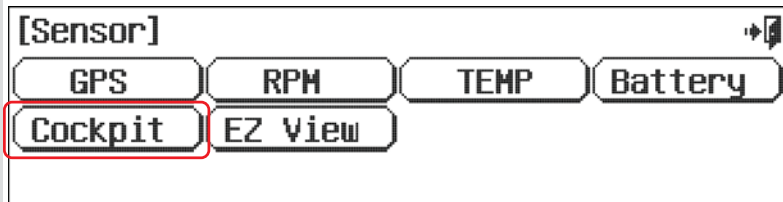

b. You can change the settings for each sensor

c. In the data screen, there is a combination mode screen on which you can view the following data.

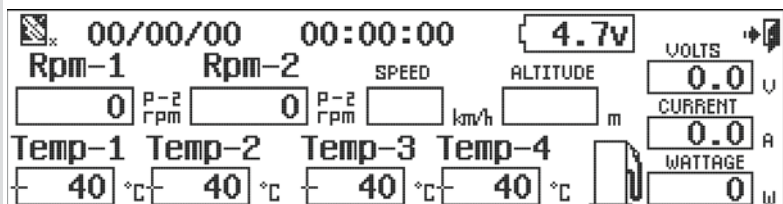

d. There is a special view mode in data screen. Using this mode, you can customize the data to your preferences.

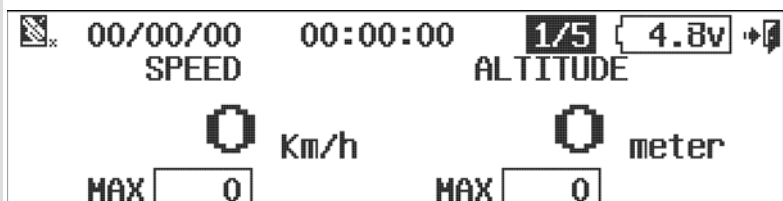

e. Press Exit icon.

## Trainer Menu

The Aurora9X can be used to help teach students how to fly with a variety of different features defined in the following section. Among the trainer features will be:

- Allowing complete or partial control to the student by selecting what controls to allow the student to use.
- Use the mix feature to let the student have a percentage of the control throw and the master uses the rest!

The Aurora 9X is compatible with all other Hitec transmitter products using the 3.2mm stereo plug or the DINN connector plug.



Warning

**When using the transmitter in the trainer mode:**

- The master radio must be programmed with the model to be flown.
- The slave or student transmitter must have the proper servo reverse and trim settings to match the master transmitter. Check this all before take-off.
- It is best to remove the module or frequency transmit crystal from the student transmitter.

To use the Aurora 9X as a “Master” radio, set the trainer switch and other features.

a. Select **Trainer** from the system menu

b. Press **ACT** to access the trainer menu



c. To further manipulate the trainer function, press the **MODE: ALL** arrow.



d. Here we can choose to limit the controls the student has access to by selecting the lower part of the column with the **OFF** icon.

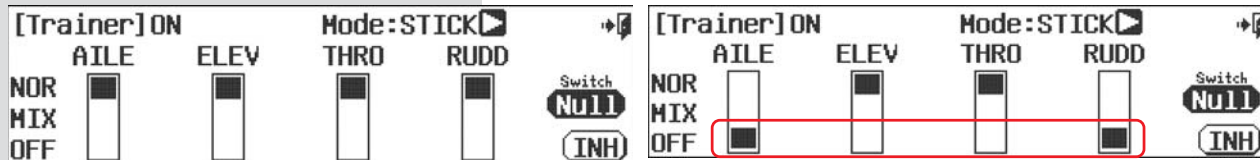

e. Another option is to limit the “rate” the student can move an individual control with the **MIX** feature. Select the center of the column to choose a “mix” between the master and student transmitter.

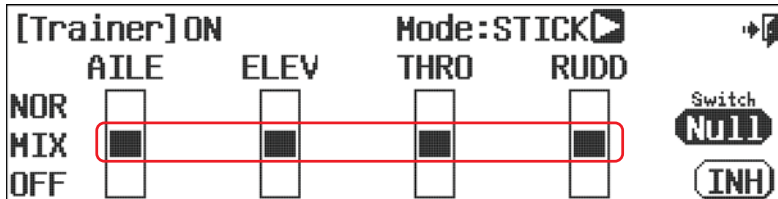

### Trainer Menu

- f. Select a switch for the trainer function.  
At this point. Press **NULL**.  
g. Press **SEL**.

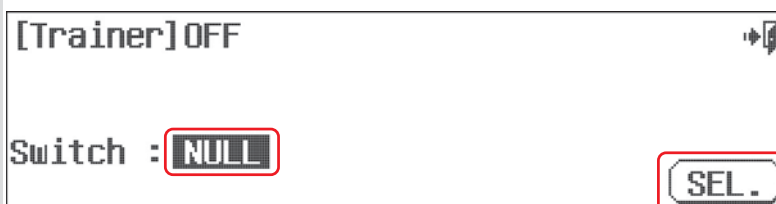

- h. Select the "dead man" switch **H**.  
i. Press the **Exit** icon and return to the trainer switch menu screen.

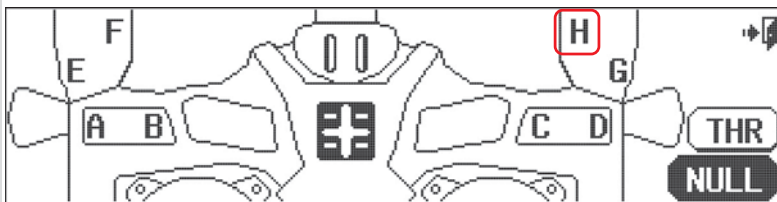

- j. Press the lower **OFF** icon.  
k. Press the **On** icon, toggle the H switch on and off to activate the student transmitter or return control to the master Aurora 9X.



- l. Press the **Exit** and return to the trainer menu screen.

- m. Next, press the **SW-H** switch icon to enter the switch menu to set the Mix rate.



- n. Press the 100% Mix Rate icon and apply a **50%** rate value with the **up** and **down** arrow icons. The result of this will be:  
o. When the **H switch** is active, the master radio will still have 50% of the control capability, even when the trainer switch is pulled. At the same time, the student's access to all the flight controls remains at a 50% rate value. This is like an "automatic dual rate" for the student and an "instant override" for the instructor.

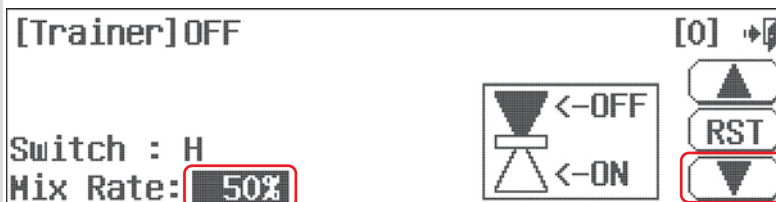

## Spectra Control Menu

### Selecting the receiver type.

- a. Select Spectra from the system menu.
- b. Select the arrow icon to change the type of the receiver.

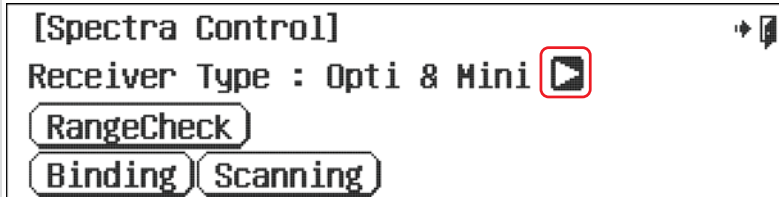

- c. After changing to Maxima, press the "SEL" icon.
- d. Press **SET**.



- e. Please check again if the change is correct.
- f. Press, **Yes**.

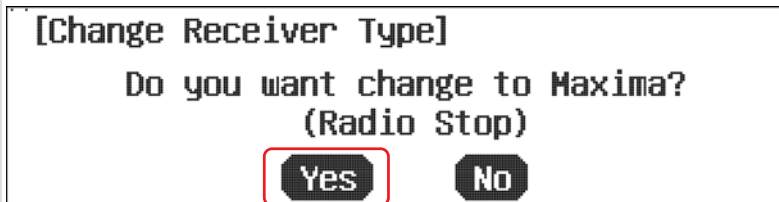

- g. You are now prompted to transmit, or not.
- h. Press, **No**

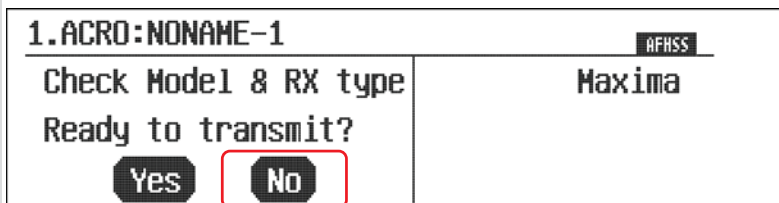

- i. Click the "Exit" icon and go back to the system menu.

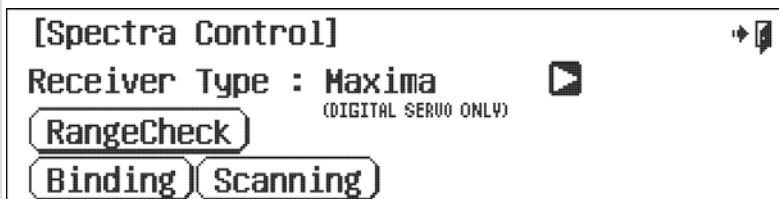

## System Management Menu

The System Management menu allows you to choose;

- Backlight time on options.
- Touch lock setting.
- Feedback setting when you touch.
- Power-off function
- Touch screen Calibration.
- Frequency warning.
- Throttle high warning.
- Flight condition warning.

a. From the system menu, select **System Management**.

b. If you click the arrow icon on the right side of the backlight, the backlight time can be set.

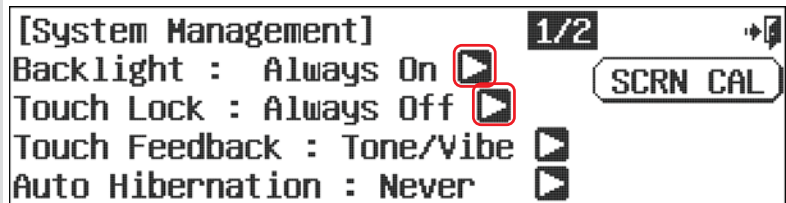

c. If you click the arrow icon on the right side of the touch-lock, the touch-lock time can be set.

d. If you click the arrow icon on the right side of the touch feedback, you can set the type of touch feedback.

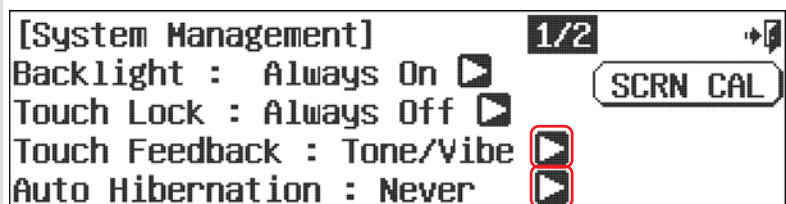

e. If you click the arrow icon on the right side of the auto power-off, the auto power-off time can be set.

f. When you click the touch screen calibration you can screen calibration.

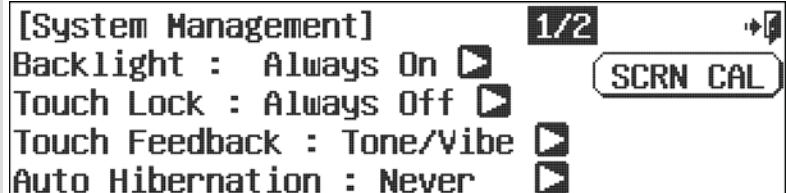

g. Check once again if the touch screen is calibration selected correctly.

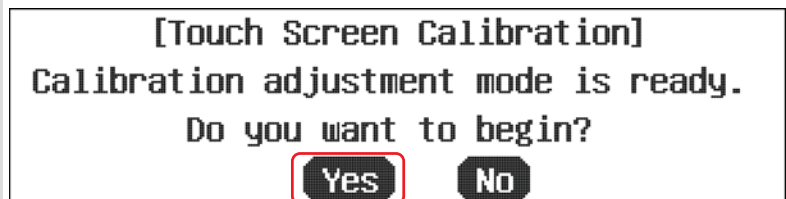

h. Use the stylus to press and hold the mark part for about 3 seconds.

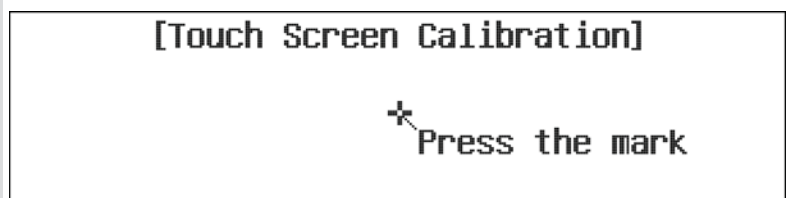



## System Management Menu

i. Use the stylus to press and hold the mark part for about 3 seconds.

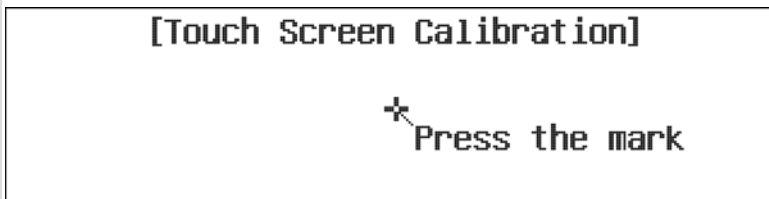

j. If you click the arrow icon on the right side of the check frequency, you can set on & off.

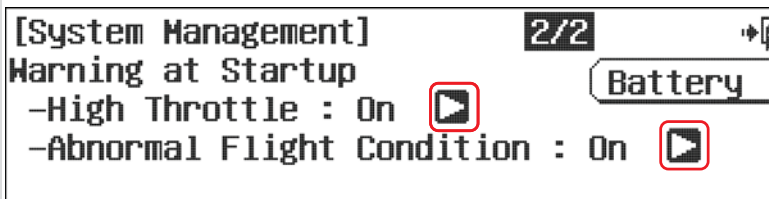

k. If you click the arrow icon on the right side the high throttle, you can set to on & off.

### Change to a Li-Po battery, the Li-Po Option

The nominal voltage of a two cell Li-Po or Lithium Polymer battery pack is 7.4V. The user has the option to power the Aurora 9X with a 2S formatted Li-Po but accepts full responsibility to do so safely. To use a Li-Po transmitter battery safely, you must remove the battery from the transmitter case for charging, and reinstall it after charging.



Caution

DO NOT install a Li-Po in the Aurora 9X and then try to charge it with the supplied CG-S45 charger. The CG-S45 was created for NiMH cells only! Major damage is sure to occur.

### Change the battery choice from Ni-Cd or Ni-MH to Li-Po.

a. At the battery screen, press the **arrow** key.

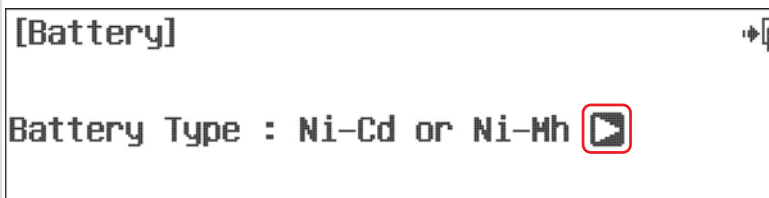

The default is for a 7.2V Ni-Cd or Ni-MH.

b. You are asked to change to Li-Po, select **Yes**.

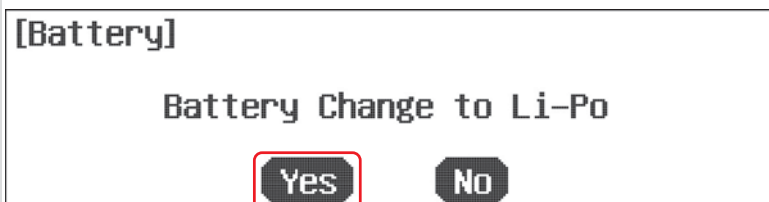

c. Here you can modify the transmitter alarm voltage from 6.0V to 6.5V in 0.1V steps with the **+RST-** icon.



Tip

Many Li-Po manufacturers don't recommend drawing the voltage of a cell below 3 volts. A two cell Aurora 9X Li-Po battery pack should not spend much time at and below 6 volts.

### Mode Menu

The mode or "stick" mode menu lets you easily select what mode you wish to use.

The Aurora 9X supports Mode 1, 2, 3, 4 and two custom modes. In America, stick mode 2 is the most popular with at least 95% preferring it. Followed by stick mode 1 users and a fractional number preferring modes 3 and 4.



Note

Mode 2 is the factory default setup for the Aurora 9X in the US market.

1. To change the stick mode, select the appropriate icon at the stick mode screen.
2. If you want to make your own custom stick mode, select the **manual 1** or **manual 2** icon.

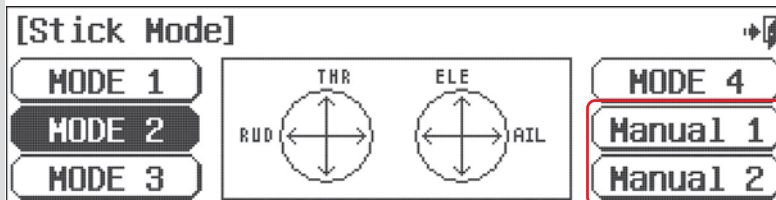

1. Identify the controller J1, J2 etc...by pressing it, and then press the corresponding function to link it to the controller. Do this until done.
2. Press the **Exit** icon twice to back out to the System menu.

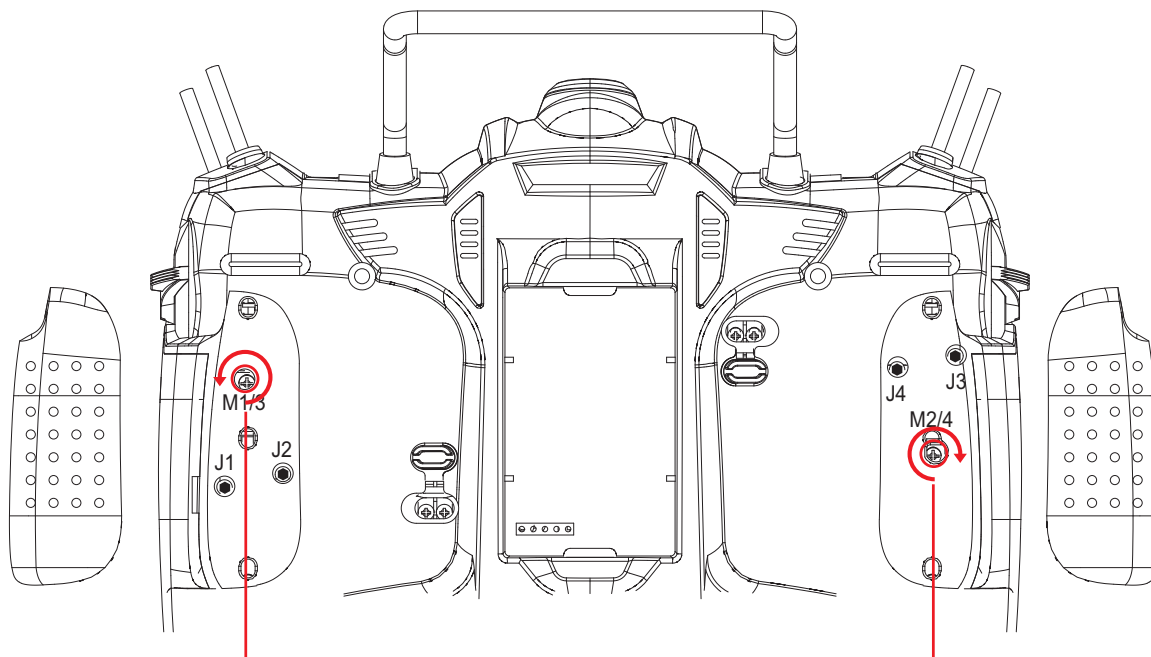
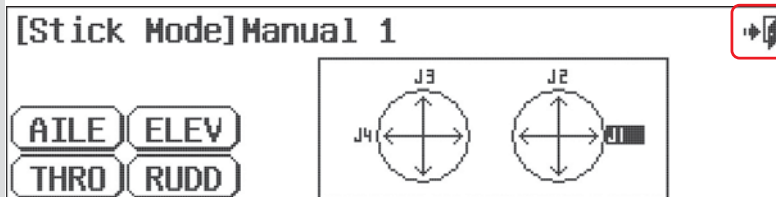

For the hardware Mode Change, a Philips(+) driver is required.  
For Mode 1 to Mode 2 change, turn the screws as shown above.

### Hardware Reverse Menu

The Aurora 9x hardware reverse feature is the ability to invert the signal of the operation of the stick, switch, etc.

a. Click the hardware reverse in system menu.

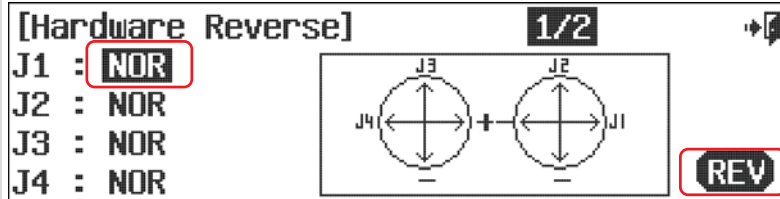

b. Select which gimbal to reverse.

c. Click the "REV" icon to convert.

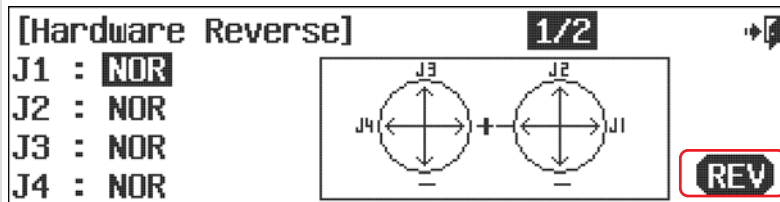

d. Select which switch to reverse.

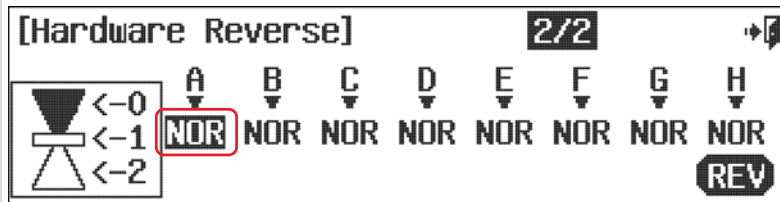

e. Click the "REV" icon and convert.

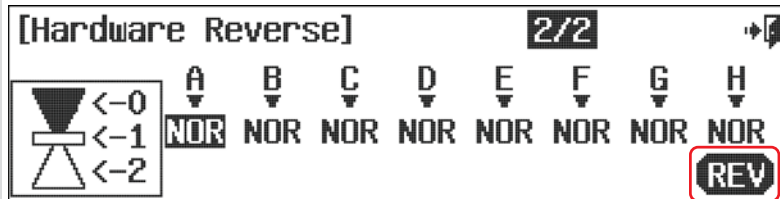

f. Press the Exit icon twice to back out to the System menu.

### Information Menu

The transmitter info screen contains the following information about the Aurora 9X.

- Program your name into the Aurora 9X
- Current language.
- Current firmware version.
- The serial number of the Aurora 9X.

To add your name to the Aurora 9X

a. From the system menu, select **Info**.

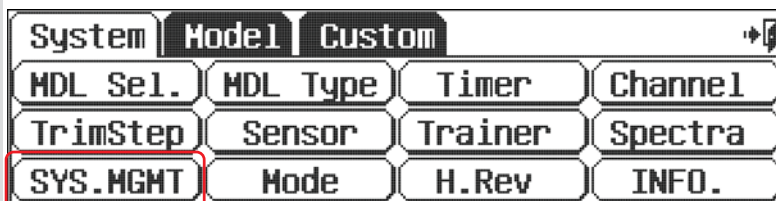

b. Press the **Rename** icon.

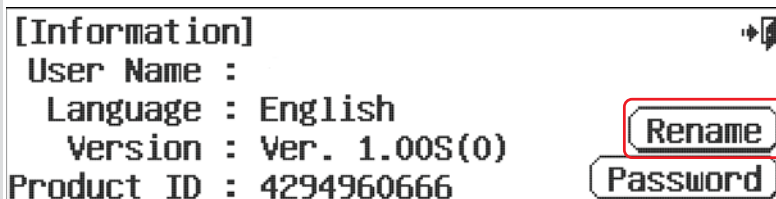

c. Type in your name at the user name menu.

d. Press **Enter** when done.



e. Press the "Password" icon.

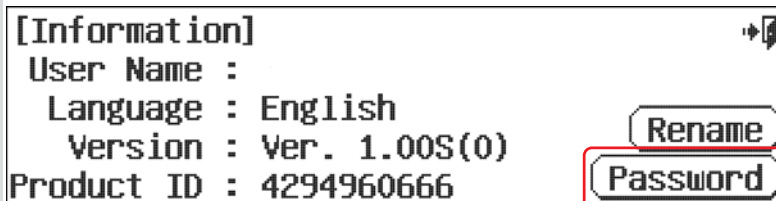

### Information Menu

f. Press the "Password" icon.

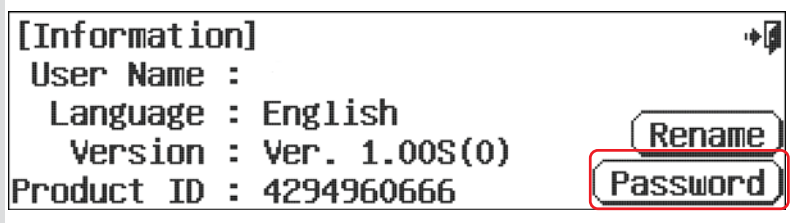

g. Enter your password and press Enter.



h. Check password once again and press Enter.



i. Press **Exit** to back out to the system menu.

### Model Menu and More Special Hints

This section contains the following information:

#### IMPORTANT PROGRAMMING TIPS

Additional menus.	Custom and Adjustment features Adjustment menu
The Switch selection process	Selecting a switch The adjust function switch set-up Camber and Launch menus Helicopter throttle and pitch curve adjust function, hover trim & more... Trim link Adjust to trim T.APP Cut Postion Launch cut

Model menu features common to all model types (airplane, glider and heli)



Once again, we encourage using the quick start guide to program your first aircraft before you journey into the model menu functions. There are many basic, fundamental lessons to be learned in spending 20 minutes using the quick start guide. Doing so will certainly speed you through the Aurora 9X learning curve.

#### \*\*\*\*\* IMPORTANT PROGRAMMING TIPS \*\*\*\*\*



#### Throttle Lock

During the set-up process, when the transmitter is transmitting to the aircraft, you can see what the effects of changing values are on the control surfaces. On the home page press the Model icon and hold it for two seconds. This action will start and stop the throttle lock.

#### Reset

As you program a model into any computer radio, especially one as sophisticated as the Aurora 9X, it is easy to make a mistake. If "things" just are not working the way they should, start over. There are thirty model memories in the Aurora 9X. Start a new model or Reset the current one in the System-MDL Sel. menu. You will lose all the programming you have done for that model up to that point, but starting over is the best "cure" for 90% of all "problems" modelers have with programming issues.

With very complex models, it would be wise to "save" a programming sequence by periodically using the Copy option in the model select menu.

#### Switches

The functions that you program into the Aurora 9X will be "on" all the time, noted as NULL on the specific features menu screen. All these features can be toggled on or off using a two position switch, or several different values can be applied to some features using three position switches. Other functions like Camber are applied to a slider and their movement is dialed-in as needed.

All these different methods for selecting and formatting switches and other control functions are described on page 68 in the manual rather than being repeated throughout the document on every other page.

#### Flight Conditions

Arguably one of the most powerful features of the 9X is the multitude of different options including the Flight Condition features which apply to the programming. We encourage you to explore how the flight conditions can influence almost every feature of the Aurora 9X. Of major note will be the C (combined) and S (separate) options that deliver an almost infinite number of programming combinations.

#### Selecting a Servo or Channel to Adjust the Value

There are three ways to select a servo or channel to adjust its travel values.

- Use the control stick to make the adjustment. Right and left, up and down to select the direction you want to adjust. This way you see the results of your input if the aircraft is turned on.
- Press the % value icon for any single servo's one direction.
- Press the name icon of the control to be adjusted and adjust both directions at the same time.

## Additional Menus, the Custom and Adjust Features

In addition to the system and model menu, there are two other menus that can appear and be used during the Aurora 9X programming process.

### Custom Menu

The Custom menu is created by the user during the programming of a model. The intent was to provide one menu screen holding up to 12 icons for the functions you use most for the active model.

a. From the home screen press the **Folder** icon.

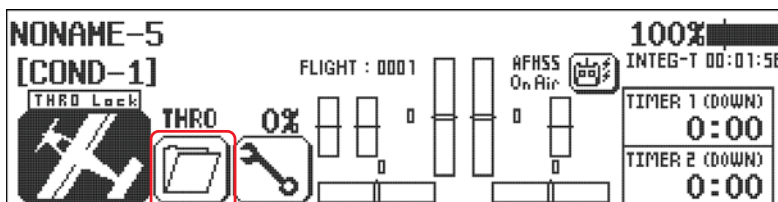

b. Press the **Custom** tab and it will change to Edit.

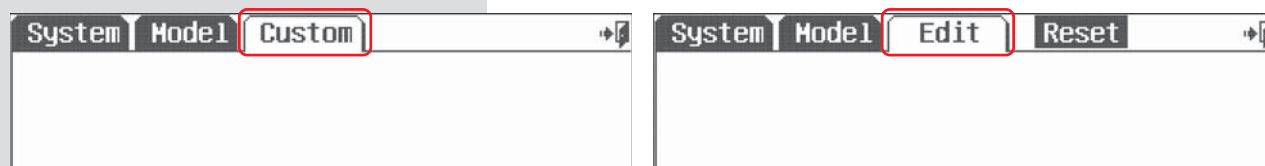

c. You can add model and system menu features to the custom folder. We will select the **model** menu for our tutorial.

d. Add feature icons to the custom menu by pressing their icons, say you adjust Aileron to Rudder and P-mixes often, touch their respective icons and highlight them.

e. Press the **Edit** tab to save and exit.

f. Press the Edit tab again, it changes to **Custom** tab.

g. Now instead of fishing through all the different feature icons in the system and model menus, you can quickly access the features you use the most.

h. To clear the Custom menu, press the custom tab and to Edit, select Reset.

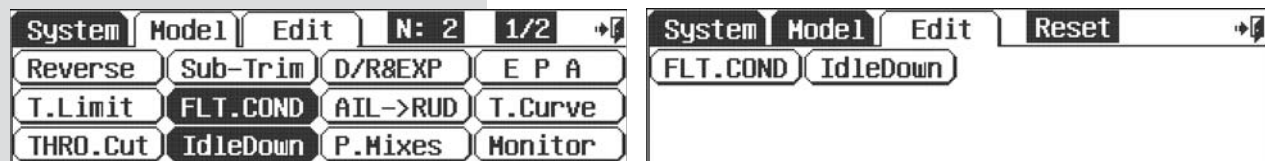

## Adjustment Menu

Many of the Aurora 9X's features offer a switch selection process. One of the options presented in several of these features is to choose an "adjustment" switch. Most often this is VR switch LT, CT, RT or a slider, LS or RS.

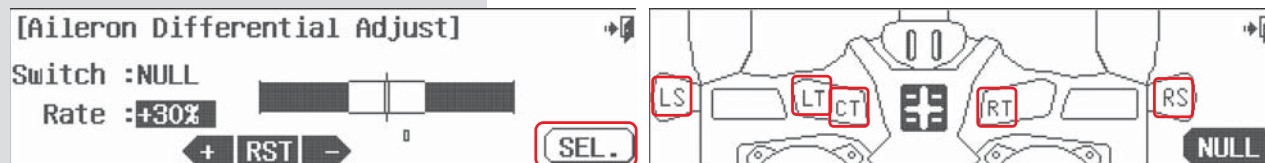

If you have selected to adjust a function with the LT, CT, RT switches or a slider, you can access the adjustment screen quickly through the Adjust menu tab which appears automatically when the adjustment option is selected during the switch select process.



Note

When more than one function is assigned to a VR switch, when the switch is toggled, the adjust menu appears so you can select the icon for the function you wish to adjust.



### Model Menu and More - The Switch Selection Process

#### Selecting a Switch

Many of the Aurora 9X features can be placed on a switch to turn the feature on / off, or provide multiple values to a function like dual and exponential rates.

To avoid repeating the switch selection process throughout the manual, we are presenting it in its entirety in this section. Here you will learn to program the following Aurora 9X switch features:

1. The NULL condition
2. Two and three position switch selection
3. Adjust function switch set-up
  - Camber and launch menus
  - Heli throttle and pitch curve adjust function
4. Trim link activation
  - Adjust to trim
  - T.APP, (trim link)
5. Cut Function set-up
  - Launch cut

#### 1. The NULL condition

The functions that you program into the Aurora 9X will be “on” all the time, noted as NULL on the specific features menu screen. Almost all of the Aurora 9X programming functions can be toggled on or off, using a two position switch, or several different values can be applied to some functions using two and three position switches. While still other functions like Camber are applied to a slider and their movement dialed-in as needed.

The question you must answer almost every time you program an Aurora 9X function will be;

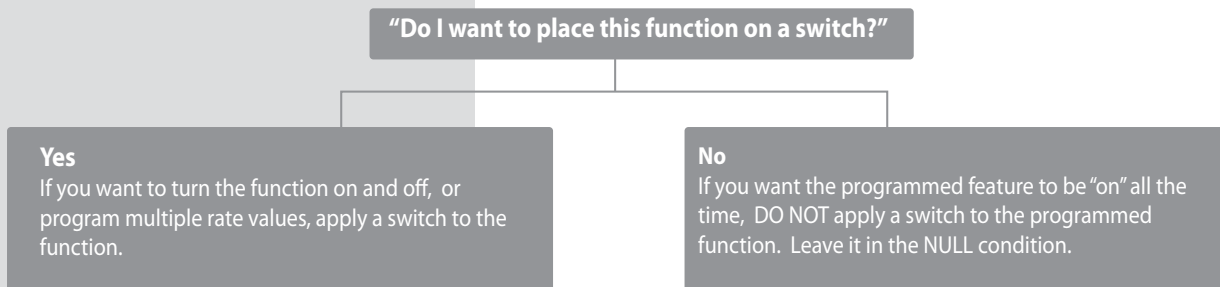

#### 2. Two and three position switch selection

There are both two and three position switches on the Aurora 9X. They are used to do two things, turn a function on and off or, each switch position can be a travel rate value on multiple rate value functions.

##### On and Off

Turn a function on or off, as when used with a switchable feature like aileron to rudder mix, the mix is either on and using the movement values you programmed for the aileron rudder mix, or the mix is turned off.

##### Multiple Rate Values

Other functions like dual rates allow you to use multiple movement rate values for different switch positions. For example, using a three position switch, you can program a different “rate” of movement for each switch position.

## Selecting a Switch

### Two position on and off

We will use the aileron to rudder mix to set up a two position switch on or off function.

a. Select the **AIL-RUD** icon from the model menu.

b. Press **ACT** to access the mix menu screen.



c. Press the **NULL** icon.

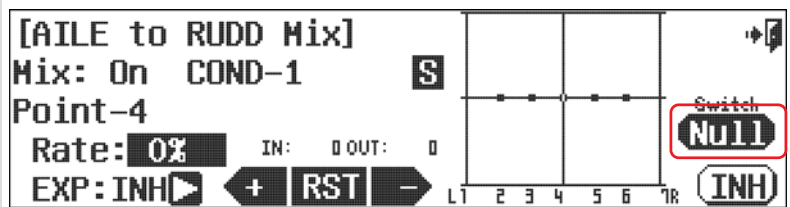

d. Press **SEL.**

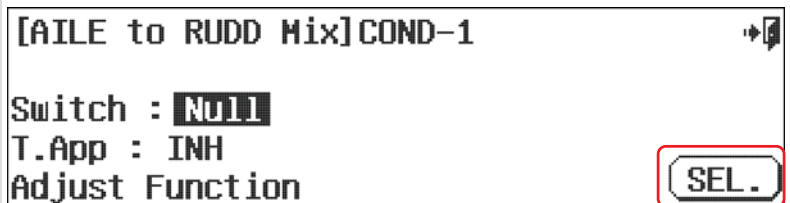

e. Let's put our switch for the aileron to rudder mix on switch A. Press the **A** icon, or simply move switch A.

f. Press the **Exit** to return to the AILE to RUDD mix switch screen.

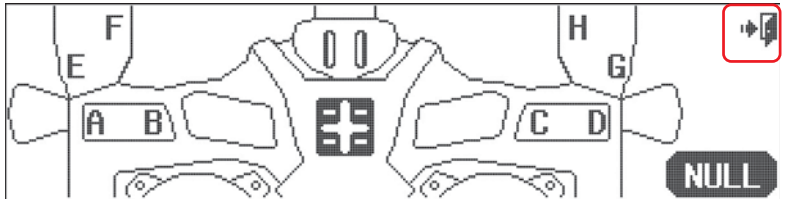

g. Press the **ON** icon.

h. Press the **OFF** icon in the corner of the screen.

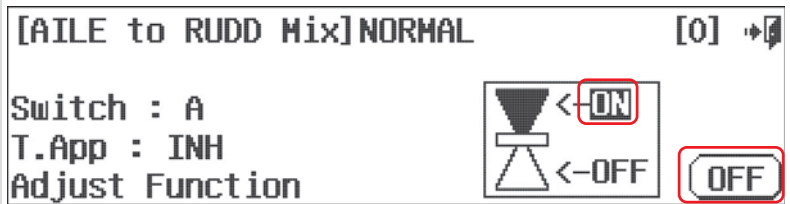

i. Select the lower **OFF** icon.

j. Press the **ON** icon.

k. Move switch **A** to see how the icons on the screen react to this movement.  
Note the switch position represented by the [0] and [1] icons.

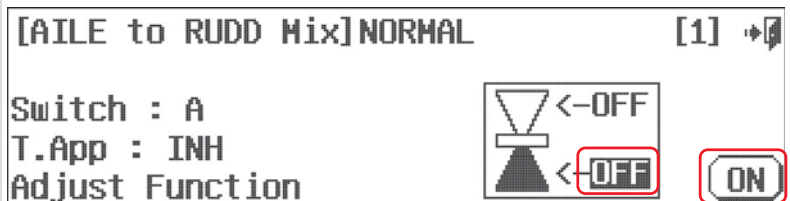

### Selecting a Switch

#### Three position switch multiple value set-up

For this example we will set three aileron movement value rates on a three position switch.



Note

Follow this method to set multiple values on any two position switch.

a. Select **D/R & EXP** from the model menu.

b. Press **NULL**.

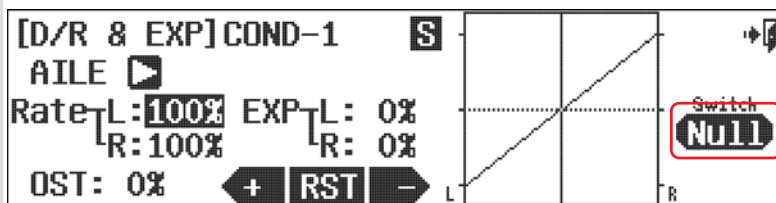

c. Press **SEL**.

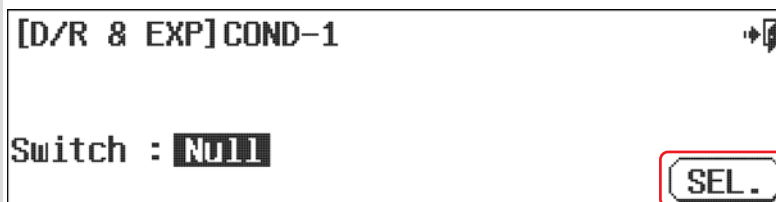

d. For our example select the switch **C** icon, or simply move switch **C**.

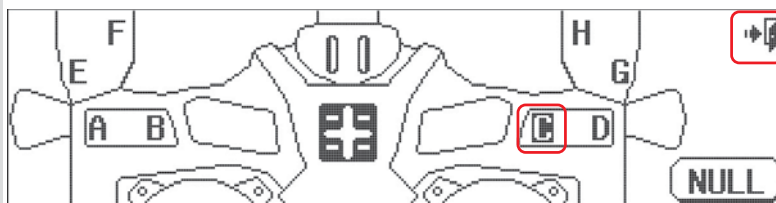

e. Press the **Exit** to return to the D/R & EXP menu screen.

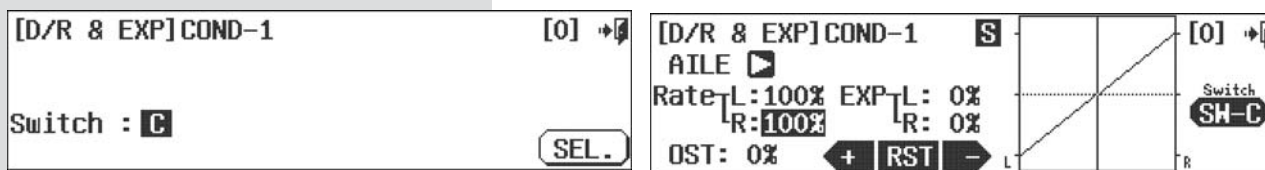

f. With switch **C** in the **[0]** position, (all the way back) press the **Rate** icon to highlight both aileron control directions.

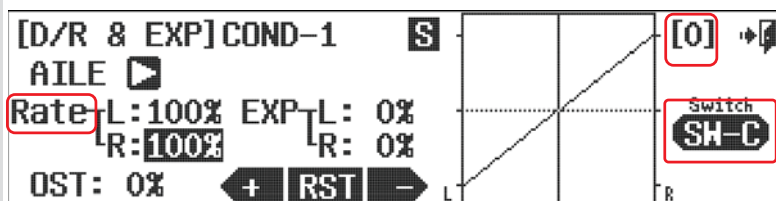

### Selecting a Switch

g. Press the + icon to get a 125% value for both the left and right aileron.

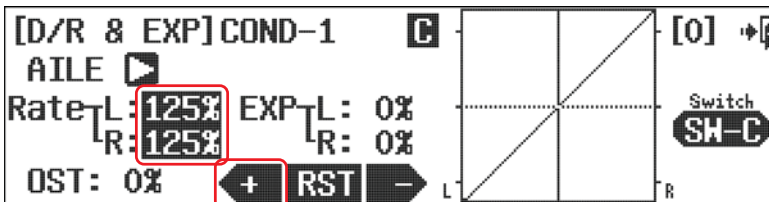

h. Move switch C to the [2] or (all the way towards you) position, bypassing the middle position.

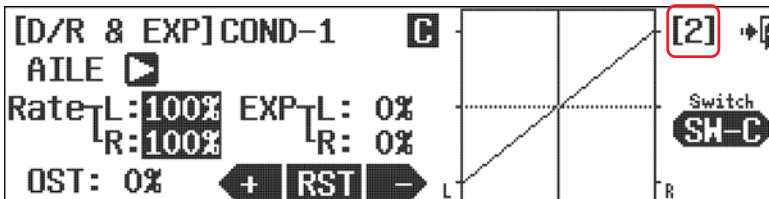

i. With the switch C in the [2] position, use the - icon to place a 75% value for the aileron movement.

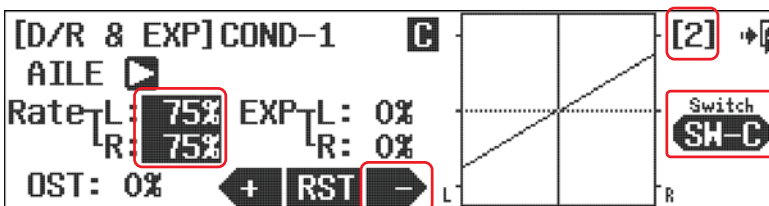

j. Now by moving switch C, we can choose a 125%, 100% or 75% movement rate for our ailerons.



Understand this is a simplified example. You can get as complicated as you find necessary to control your model to your satisfaction by using flight conditions in conjunction with the C and S feature.

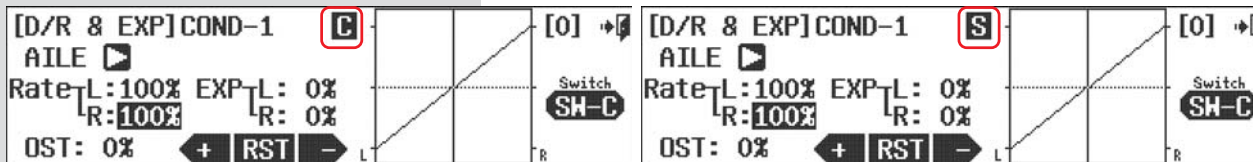

Press C to change it to S (Separately)

Press S to change it to C (Combination)

### Adjust Function switch set-up

The adjustment feature was created to allow the fine tuning of a function like the aileron to rudder mix while the aircraft is flying. To show an example of this feature, we will return to the aileron-rudder mix switch screen.

a. Press AIL --> RUD from the Model menu

b. Press SW-A icon

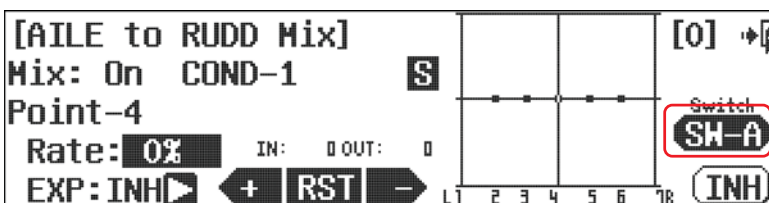

### Adjust Function switch set-up

c. Press the **Adjust Function** icon.

d. Select **SET**.

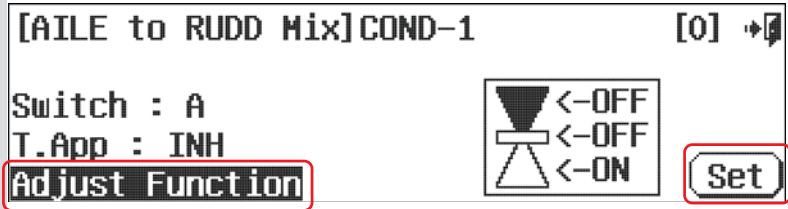

e. Press **SEL**.

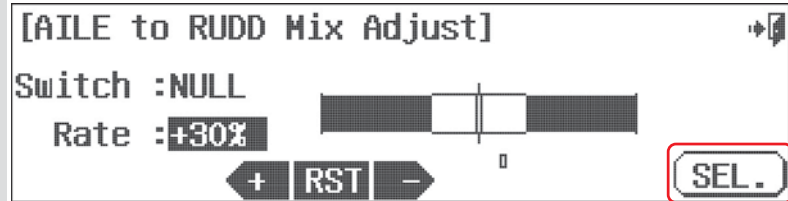

f. Let's choose the **LT** switch to adjust the aileron to rudder mix.

g. Press the **Exit** icon to go back to the AILE to RUDD Mix Adjust screen.

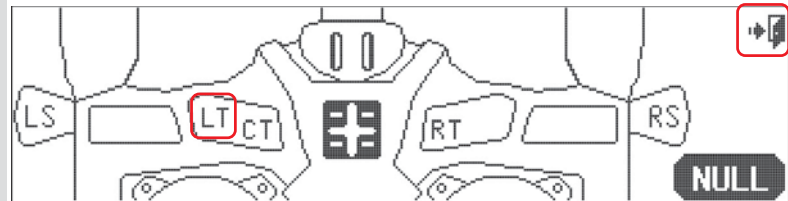

h. If we want to expand or contract the adjustment range the LT switch is capable of, press the **+RST-** icon and note the effects.

i. Press the **Exit** icon repeatedly until you have backed out to the home screen.



j. Use the **LT** switch and apply a value to the aileron to rudder mix. Note its effect on the model.

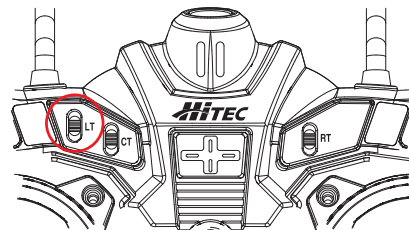

### Additional camber and launch mode adjust function menu (GLID)

The Camber Mix and Launch features have several screens in the adjustment menu allowing you to set adjustment travel rate values for the control surfaces used in the Launch and Camber functions when the function is active. Select a control surface value to change, and change the value with the +RST- icon.

This is the Camber mix screen.



### Additional camber and launch mode adjust function menu (GLID)

This is the Launch mix screen.

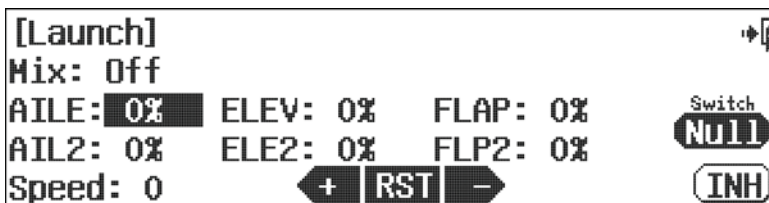

### Helicopter throttle and pitch curve adjust functions, hover trim and more

The heli mode throttle and pitch curve adjustment menus offer several options for in-flight adjustment of hover throttle and pitch trim. The pitch curve also includes a high pitch adjust, and a low pitch adjust switch option.

In throttle curve adjust function menu you can choose:

- Throttle hover
- Throttle with pitch hover

In the pitch curve adjust function menu you can choose:

- Pitch hover
- Pitch curve high pitch adjust
- Pitch curve low pitch adjust



- Check out all the throttle and pitch curve adjust functions. Learning to use these features can dramatically improve the performance of your heli without the expense of hardware upgrades.
- Use them all, or select between them.

We will first describe the throttle hovering adjustment menu. All other throttle and pitch curve adjustment menus are identical in the way they are programmed, so as to avoid repetition in the manual text, we offer the adjust function process explanation just once.

#### Throttle and Pitch curve adjust function programming

We will use the throttle curve adjust screen and hovering switch set-up for our example.

a. Press the **ACT** icon to activate the feature.

b. Enter the throttle curve switch menu by selecting **NULL** at the throttle curve menu screen.



c. Press **Adjust Function**.

d. Press **Set**.

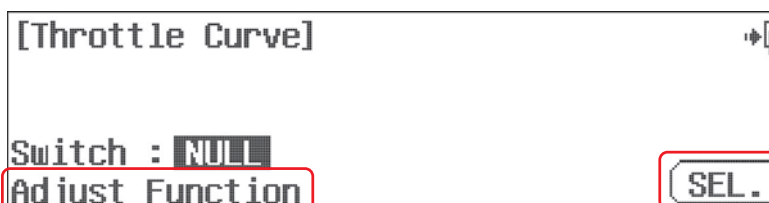



### Helicopter throttle and pitch curve adjust functions, hover trim and more

d. Here at the Throttle Hovering adjustment screen we can select to place the throttle hover trim on a control, press **SEL**.

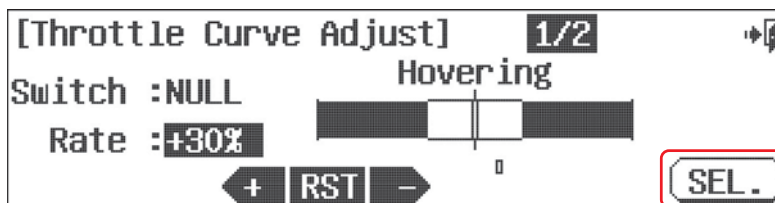

e. Select the **LT, CT, RT** or right slider (**RS**) to control the throttle hover adjustment.

f. Press the **Exit** when done selecting a controller.

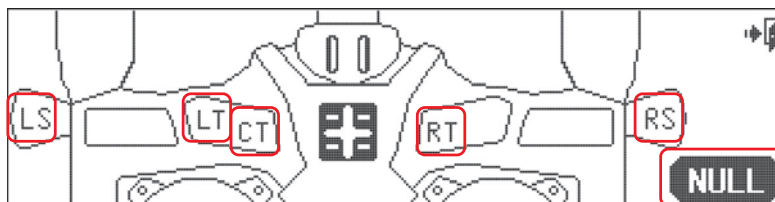

g. Adjust the rate value with the **+RST-** icon if you want to expand or decrease the adjustment size capability of the selected controller.

h. At this time you can select page two of the adjust menu, by pressing the **1/2** fraction icon.

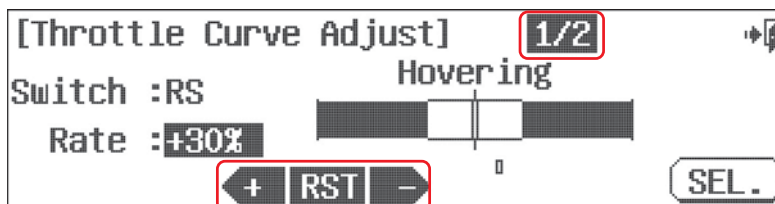

i. If you want to set an adjustment switch for the throttle hovering with pitch option, do so as described in this section, d through g

j. Press the **Exit** to return to the throttle curve menu.

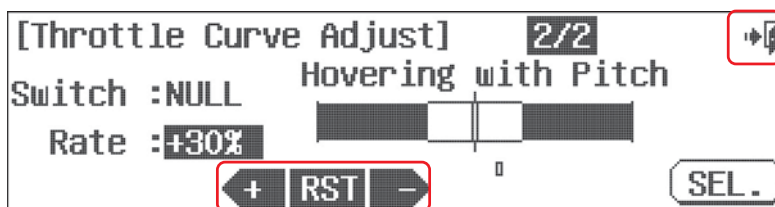

### Trim Link Activation

Modern computer radios use a digital trim system. The Aurora 9X features four trim controls for the throttle and the three main axis of flight, pitch (elevator), roll (aileron) and yaw (rudder).

There are occasions when you may want to link the trim of one control to another control. The Aurora 9X offers two different trim link features; the "Adjust to Trim" and the "T.APP" (trim apply). Both are explained in the following text.

#### Adjust to Trim

You will see the "Adjust to Trim" option in the throttle control menus: throttle cut, idle down and throttle hold.

The goal of activating the "Adjust to Trim" feature is to link the rate values we programmed for throttle positions, so they can be adjusted with the throttle trim.

Our example will be the Idle down function.

a. At the idle down function switch menu screen press the Adjust to Trim : **INH**.

b. Select **ACT** to activate the trim link. (this screen not shown)

c. Reverse this process to inhibit, or turn off the trim link.





## Trim Link Activation

### T.APP

The T.APP or “Trim Apply” is a trim link feature allowing the linking of two flight control trim functions, primarily a feature of critical mixing functions.

Again we use the aileron to rudder mix as an example. The default is to have the trims separate.

To activate a trim link between aileron and rudder, so that adjusting the aileron trim will also adjust the rudder trim:

a. At the rudder /aileron switch menu screen, press the T.App : **INH**.

b. Press **ACT**, the trim link is turned on.

c. Reverse this process to inhibit, or turn off the trim link.

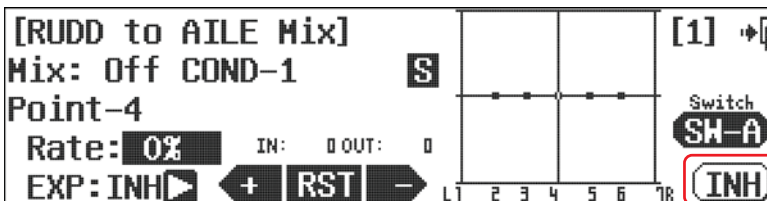

## Cut Position set-up

Cut position is used to set an initiation point or a cut-off point for a specific function. We will use the Throttle Cut feature in our example.

After selecting the recommended throttle cut switch H, do the following:

a. At the Throttle Cut switch menu screen, press the **Cut Position** icon.

b. Move the throttle stick up and down, note the line on the bar graph as it moves.



c. Press the **50%** icon on the graph.



d. Move the throttle stick to the position you want the throttle cut action to take effect. Note the throttle will drop to the rate position you previously selected when the switch H is toggled, ONLY WHEN THE THROTTLE STICK POSITION IS BELOW THE CUT POSITION you are about to set.

e. We suggest you move the throttle stick to the 30% position, then press **SET**.



The throttle cut feature is now going to work only when the throttle position is at the lower 1/3rd of the throttle stick travel stick, and then only when switch H is toggled.

### Launch Cut switch set-up

The launch mode features the option to have the cut control be applied to a stick movement.



Note

The launch function must have a switch assigned to it for the cut function to work.

a. At the launch mode switch menu, press the Cut Function : **Null** icon.



b. Press **SEL.**

c. For our example we will place the Launch cut on the elevator. Press **ELEV.**

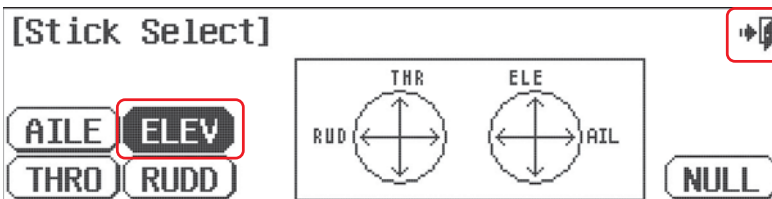

d. Select the **Exit** and return to the Launch mode switch menu.

e. Press the Cut Function : **ELEV** icon.



f. Move the elevator stick up and down. Note the movement displayed on the bar graph.

g. Press the **100%** icon on the bar graph.



h. Move the elevator stick to the cut position. For our example, move the elevator stick half way up (away from you as in "down" elevator input) hold it there and press the set icon. We are looking for about a 75% value.



i. Press the top **OFF** icon.



j. Then press the **On** icon.

The result is the ability to select a launch mode by turning it on with your switch. The flaps, ailerons and elevator should move to their pre-programmed launch position for a pedal launch or high start. At the apex of the launch, when the "round-out" process is started with down elevator input, the launch mix is "cut" or de-activated when the down elevator is applied.

### Model Menu and More - Menu Functions Common to all ACRO, GLID and HELI models.

The following features are common to the ACRO, GLID and Heli model programs. Depending on the active model features as you defined them during the model set-up process, these functions may or may not be in the model menu.

The following functions are defined in this section:

EPA	End Point Adjustment
D/R&EXP	Dual Rates and Exponential (expo) Rates
Sub-Trim	Servo Sub-Trim Adjustment
Reverse	Servo Reversing Function
S. Speed	Servo Speed Feature
T.Limit	Travel Limit
Monitor	Active Model Control Monitor
P. Mixs	Programmable Mixing
Gyro	Gyro Functions

Access the model menu from the home screen by pressing the **aircraft** icon representing the active model.

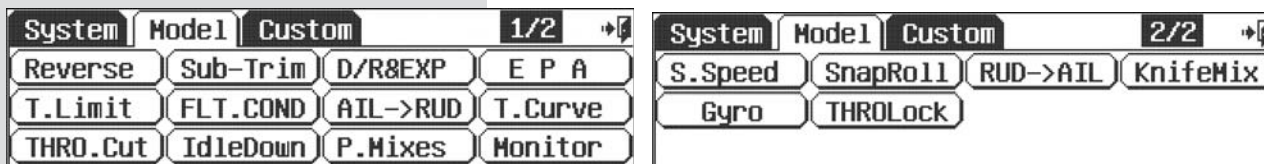

Note the 1/2 icon. There are normally two pages to the model function menu, in very sophisticated airframes there can be three pages.



It is recommended you start the set up of your model using the functions listed in the following order:

1. Servo Reverse
2. Sub-Trim
3. EPA or end point adjustment

After programming these very basic functions, your model will be prepared for more advanced programming.

### EPA (End Point Adjustment)

EPA stands for “End Point Adjustment”. With the EPA function, you can set both sides of the servo arm travel at the same time, or separately. This function can help avoid binding or damaging the aircraft control surfaces.



- There are two screens to the EPA menu. Note the 1/2 icon.
- The EPA range is 0% to 140%.
- Sub-Trim and Dual Rate and functions can impact the programmed EPA values.

a. Select **EPA** from the Model menu.

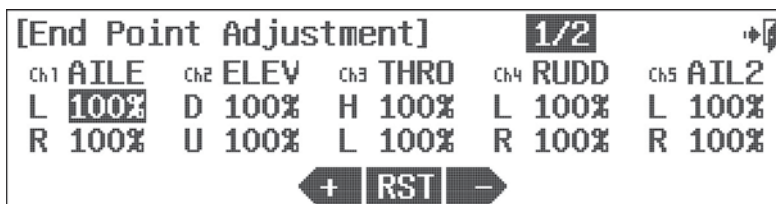

- b. Press the icon of the servo channel you wish to adjust.
- c. Move the aileron control stick all the way to the left. The L 100% should be highlighted.
- d. Using the + RST - icon to set an appropriate movement value.
- e. Now move the stick right and set the travel value for the right aileron function.
- f. Repeat these steps for all the channels you wish to set an EPA value.
- g. When done, back up to the model menu by selecting the **Exit** icon.

### D/R & EXP (Dual Rates and Exponential Rates)

This menu contains three valuable features. We will first discuss and show a dual rate set-up, then discuss and demonstrate exponential, or “expo”. The OST (Offset) feature can be applied to any channels “movement graph” as required. It will be discussed last.

### This function can be influenced by the flight condition feature ###

#### Dual Rates, Exponential Rates and Curve Offset Features

Dual rates allow the user to set two or three servo throw “rates” for a control surface, or channel. These movement rates are then selected during flight with a switch.

Exponential rates (expo) is a gem of a feature, often overlooked; expo can make a poor pilot look great. We bet you will want to use a negative expo value on all your aircrafts aileron and elevator controls.

While not as widely used as Dual rates and Expo, the Offset curve feature allows you another way to change the normally linear servo movement and “skew” it.

a. Select **D/R & EXP** from the Model menu.

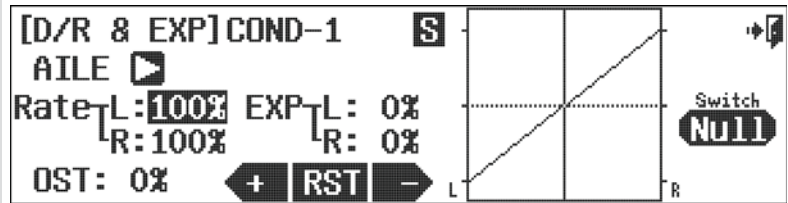

#### Switch Option

b. Press **NULL** to apply the dual rate function to a two or three positions switch. You can have a different rate on each switch position. See page 68 for the switch selection process.

Switch type	Function
2 or 3 position switch	Multiple values

- c. Cycle through the active model controls using the **arrow** icon. Select the control you want to program a dual rate setting for.
- d. Move the control stick for that channel and hold it at the extreme throw position. Select a value for that stick positions low rates using the **+RST** icons.
- e. Move the control stick to opposite extreme position, hold it there and set a value for that stick positions low travel value rate.
- f. This low travel rate is now active in current position of the switch you selected in section b. Flip the switch to the next position and the values should be at 100%. The 100% value is your high rate for that control.
- g. At this point, we suggest you press the **EXP: 0%** icon. Adding a negative value here will skew the movement curve from linear to exponential. We suggest a -50% value be used on your high and low rate switch position.
- h. Press the **OST: %** icon. Note the effect of the **-** and **+** inputs from the **+RST** icon. Modify the curves of the flight controls surfaces as required.
- i. Set a dual, exponential and offset curve value rate for any other channels, or servos by pressing the **arrow** icon to cycle through the active models controls and following these directions.
- j. Press the **Exit** icon to exit back to the model menu.



- There are hundreds of combinations of expo and dual rate values that can be created within the Aurora’s model programming menu. Experiment to see what works best for you.
- Put the dual rates for several different controls on the same switch, or have them be activated by a different switch.
- Make sure you are adding values to channels with the switch in the correct position.
- Add your expo values when you set-up the dual rate values as you get more experience with your Aurora.

### Sub-Trim (Servo Sub-Trim Adjustment)

Your servo control arms should be as close to 90 degrees as possible, and the control surfaces as close to level as you can make them by adjusting the control linkages. Use the sub-trim feature to make very small adjustments to “center” the control surface.

a. Select **Sub-Trim** from the model menu.

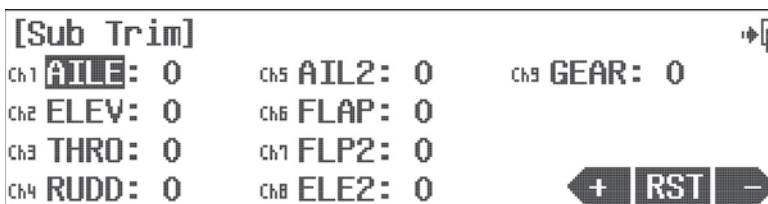

b. Select the control/channel to adjust by pressing its respective icon.

c. Using the **+ RST -** icon at the screen's lower right corner, adjust a value as necessary by selecting the plus or minus icon. Select **RST** to bring the value back to zero if you wish. You should see the control surface moving as changes are made with the **+ or -** icon.

d. Follow this procedure for any channels requiring sub-trim.

e. When done, back up to the model menu by selecting the **Exit** icon.



Caution

Sub-trim is not the place to do a major adjustment. Any servo needing more than 40 points of movement should be adjusted by moving the servo control horn and adjusting the linkage.

### Reverse (Servo Travel Direction Reverse)

Are all your servos traveling in the correct direction? Use this menu to change the direction for any of the active model's channels.

a. Select **Reverse** from the model menu.

b. Move your controls, are all the servos going in the correct direction? If not, select the channel to reverse, then press the **REV** icon.



c. If this is correct press the Sure? **Yes** icon.

d. Do this process until all servo throw directions are correct.

e. Back up to the model menu by selecting the **Exit** icon.



### S. Speed (Servo Speed Adjustment)

The servo speed menu will allow the manipulation of the servo speed through its travel. Servo speed can also be modified in several other menus using the ACC (acceleration) feature and the Speed option.

### This function can be influenced by the flight condition feature ###



Note

- Servo speed can only be slower.
- Choose to slow the transit speed of the selected channel in one direction, or both directions.
- The value applied is in seconds.
- The servo speed function is a two screen menu. Note the 1/2 icon.
- Servo speed values can be changed in different flight modes.

a. Select **S. Speed** from the model menu.

b. Press **ACT** to activate the servo speed function.



c. Choose the channel to change by pressing its icon.

d. Press the **+** icon to select a value to slow the servo transit time.

e. Press **RST** to return the value to zero.

f. When finished, press the **Exit** icon to return to the model menu.

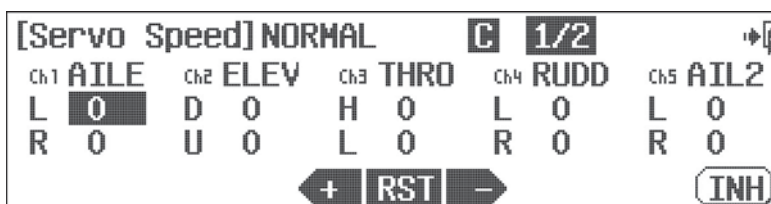

### Monitor (Control Movement Monitor)

The servo monitor function will display a graphic representation of all nine channels as they are manipulated with the Auroras 9X's controls. There is also an Auto test function that will cycle through the servo movement automatically.



Note

Only channels used for the active model are shown to move on the monitor screen.

a. Select **Monitor** from the model menu.

b. Move the controls around and see the bar graphs move.

c. Select the **Exit** icon to return to the model menu.

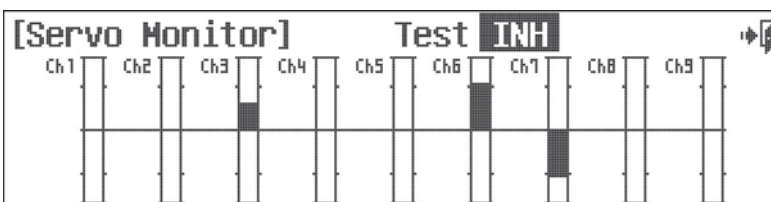

#### Servo Monitor Auto Test function

- At the servo monitor screen press the Test **INH** icon.
- This will cause an automatic cycle function for all active model control channels.
- Use the throttle stick position to increase or lower the auto test speed.
- Press Test **ACT** to return to the manual test mode.
- Select the **Exit** icon to return to the model menu.

### T.Limit (Travel Limit)

This function is to set the maximum End Point of the servo.

- Select T.Limit in model menu.
- Select the servo channel that you want to set up.
- Locate the Trim in L position by moving the aileron stick all the way to left.
- Input the value that you want by using **+ RST -** Icon.
- Repeat the above steps to set other channels.
- When you are finished, click the Exit icon to return to the model menu





### P. Mixes (Programmable Mix Menu)

The Aurora 9X is capable of eight P. Mixes. Due to the number of ways the nine channels can be mixed, we want to illustrate an example of P Mix or “programmable mixing”. For this example we will mix throttle to rudder. The goal is to apply a small amount of rudder as the throttle is advanced to counteract the P-factor.

### This function can be influenced by the flight condition feature ###

a. Select **P. Mixes** at the Model menu.

b. Select **INH** for the first open P mix.

c. Press **ACT** to enter the P mix program menu.



d. Press the **THRO** icon.



e. Press **RUDD**.



f. Select the **Exit** icon.



g. We are now back at the first P mix screen, our P mix 1, THRO-RUDD should be highlighted.

h. Press **Select**.

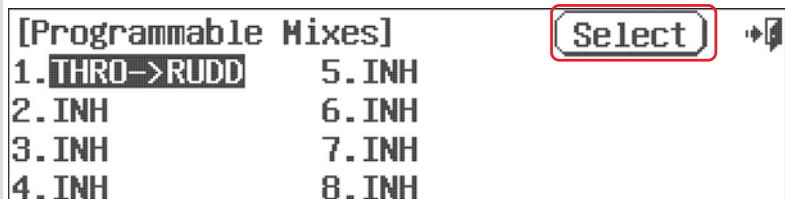

**P. Mixs (Programmable Mix Menu)**

i. In our example, throttle control is the “master”, if the throttle is moved the rudder will move. We must add the amount or “rate” value we want the rudder to move. Move the throttle stick up and down, the H and L values will alternately be highlighted and the throttle line will cross the graph.

j. With the throttle at the low position, add +10%.

k. With the throttle at high position, add +10%.

l. Press the OST: 0% icon.

m. Give the OST function a +10 value, note the line movement.

n. Use the ACC feature to change the speed of the mix. Press the ACC: 0% icon. Experiment with positive and negative values watching the results on your model.

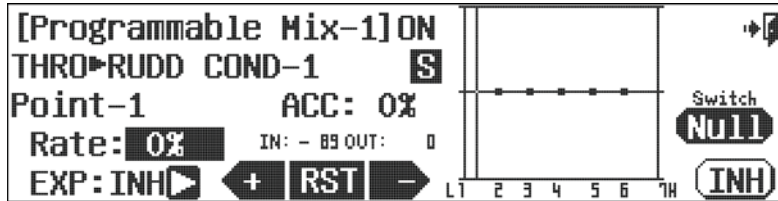

Our goal has been reached. Now as the throttle is advanced, a slight amount of rudder is automatically mixed in to counteract the tendency the aircraft has to turn in the direction of the prop rotation.

**Switch Option**

o. We can choose a 2 position switch to switch the mix on or off and activate a trim link. Press NULL.

Switch type	Function	Trim link
2 position	On or Off	Yes, T.APP

p. Select the Exit icon to return to the model menu.

### Gyro (on/off and Sensitivity Adjustment)

It is often desirable to use a gyro on one or more flight control surfaces of both fixed wing aircraft and the on the tail rotor of helicopters. The Aurora 9X features up to three gyro sensitivity and switch control options per model memory, GY-1, GY-2 and GY-3.

### This function can be influenced by the flight condition feature ###



Note

To effectively set-up the gyro sensitivity function you should have the gyro manufacturer's instruction manual available to you.

#### Gyro set-up for fixed wing aircraft

a. We first associate a gyro sensitivity function to an open channel.

b. In the system menu, select **Channel**.

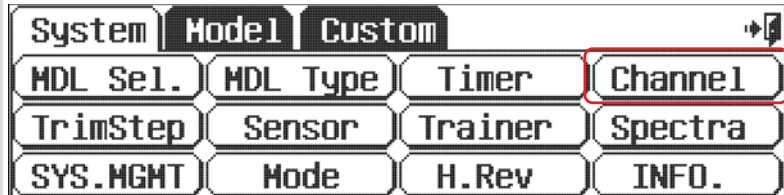

c. Add a gyro channel by pressing the **AUX1** icon.  
d. Press SEL.

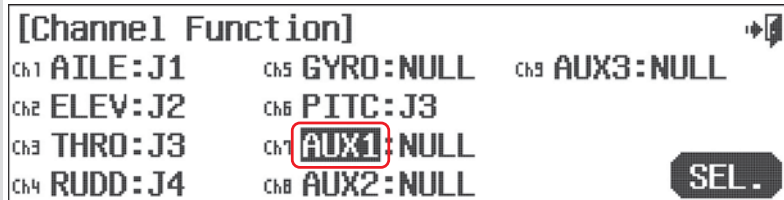

e. Choose **GY-1**.

f. Press **SET**.

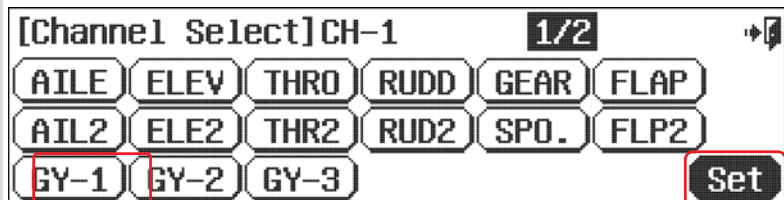

g. Press the **Exit** icon once.

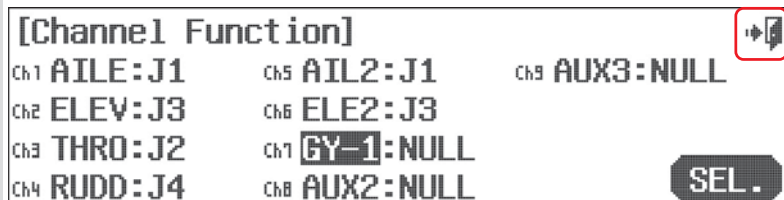

h. Select the **Model** menu.

i. Select **Gyro** from the model menu.



**Gyro (on/off and Sensitivity Adjustment)**

j. Press **ACT** to activate the gyro sensitivity menu.



**Switch Option**

k. Here we can choose a two or three position switch to apply different sensitivity values.

Switch type	Function
2 or 3 position	Multiple values

l. The default sensitivity value is 50%. Follow the gyro manufacturer's guidelines and apply an appropriate % value with the **+ RST -** icons to all the different switch positions for the switch you have selected.

m. Select the **Exit** icon to return to the model menu.



### Model Menu-Common Model Functions to ACRO and GLID

The following features are common to the ACRO and GLID model programs. Depending on the active models features as you defined them during the model set-up process, these functions may, or may not be in the model menu.

FLT.COND	Flight Conditions	
Spoiler	Spoiler control	
SPO- ELE	Spoiler to Elevator mix	
AIL-RUD	Aileron to Rudder mix	
ELE-CAM	Elevator to Camber mix	
RUD-AIL	Rudder to Aileron mix	
AIL DIFF	Aileron Differential feature	
AIL- FLP	Aileron to Flap mix	
CAMBMIX	Wing trailing edge mix	
FLP CON	Flap control mix	
V.Tail	V-Tail mix feature	
AILEVATR	Split elevator and aileron inclusion mix	
Elevon	Elevon or flying wing mix	
Thro.Cut	Throttle cut position	
T.Curve	Throttle curve	
IdleDown	Throttle Idle down position	
B-fly	Butterfly or "Crow" mix	
FlapTrim	Flap Trim Mix	ACRO only
Knifemix	Knife Edge Mix	ACRO only
SnapRoll	Snap roll function	ACRO only
Offset	Offset function	GLID only
Motor	Glider motor control feature	GLID only
Launch	Launch mix	GLID only

### FLT.COND (ACRO)

#### Flight Conditions

The Flight Condition feature is clearly the most sophisticated and flexible of all the Aurora 9X functions.

There are 7 flight conditions, condition 2 through 8. This is in addition to the NORMAL condition for a total of 8 different flight conditions you can program for the active model's memory.

As you read the manual, note this graphic appears at the end of the description text on the following functions:

**### This function can be influenced by the flight condition feature ###**

The following Aurora 9X features support flight condition programming in ACRO and GLID.

- |                            |                         |
|----------------------------|-------------------------|
| 1. Dual Rate & Exponential | 11. Aileron to Flap Mix |
| 2. Servo Speed             | 12. Camber Mix          |
| 3. Programmable Mixes      | 13. Launch              |
| 4. Throttle Curve          | 14. Flap Control        |
| 5. Fuel Mixture            | 15. Gyro Sensitivity    |
| 6. Spoiler to Elevator Mix | 16. Snap-Roll           |
| 7. Aileron to Rudder Mix   | 17. V-tail Mix          |
| 8. Elevator to Camber Mix  | 18. Elevon Mix          |
| 9. Rudder to Aileron Mix   | 19. Ailevator Mix       |
| 10. Aileron Differential   | 20. Knife Edge Mix      |



You are not obligated to use the flight condition feature to fly an aircraft.

**FLT.COND (ACRO)**

**The flight condition tutorial**

To show you how to set-up, and use the Aurora 9X flight condition feature, follow along with this tutorial. You can change the switch location and other options when you choose to do this on your own later.

We will create two flight conditions, condition 2 and 3. These two new flight conditions are in addition to the NORMAL condition. When we are done, the NORMAL condition will be with the C switch back, or in the [0] position. The condition 2 will be active when the switch is in the middle, or [1] position. Condition 3 will be active when the switch is placed forward, or in the [2] position.

a. Press **FLT.COND** in the model menu

b. Press **Insert**



c. Press **Cond-2**

d. Press **SET**

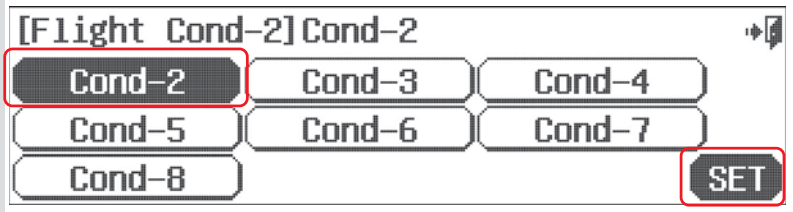

e. Press **NULL** to select a switch

f. Press **SEL**

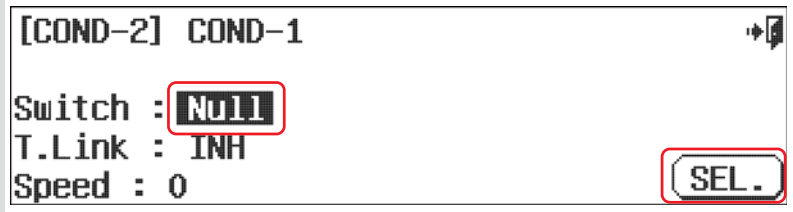

g. Press the **C** icon for the 3 position switch C

h. Press the **Exit** icon

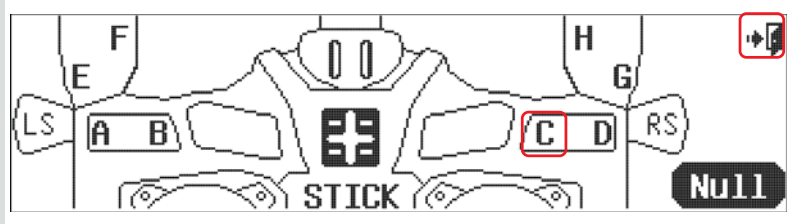

i. Move switch **C** and note the changes to the switch icon. With the switch in the middle position, press the **OFF** middle position icon.

j. Press the **ON** icon.

k. Press the **Exit** icon.

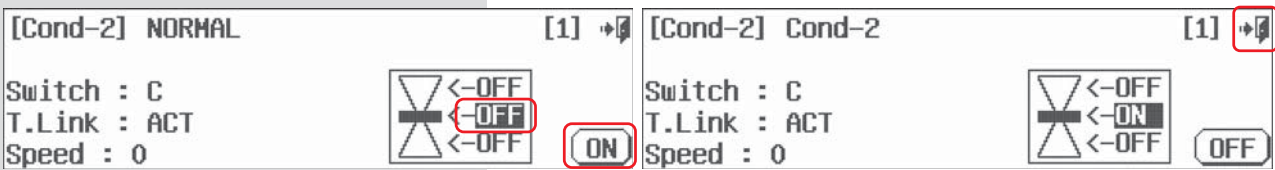

### FLT.COND (ACRO)

l. Now we set-up "condition 3" the same way.  
Press **INSERT**

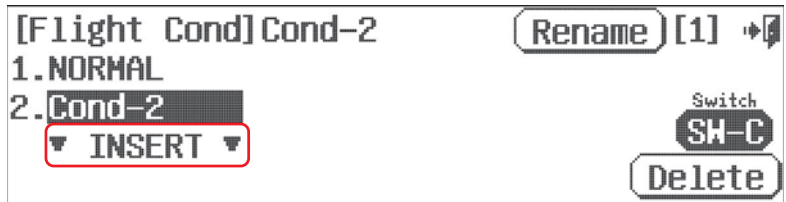

m. Press **Cond-3**

n. Press **SET**

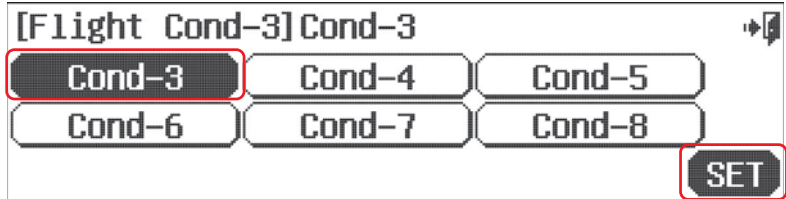

o. Select **NULL**

p. Press **SEL**



q. Press the **C** icon for the 3 position switch C

r. Press the **Exit** icon

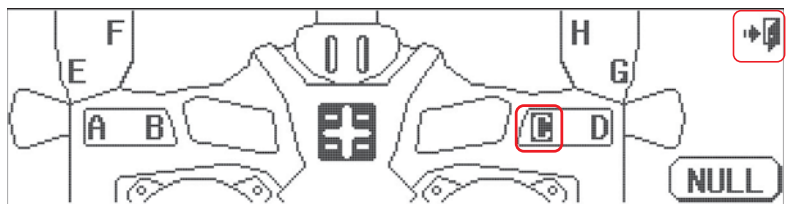

s. Move switch C forward to the [2] position. Press the **OFF** lower position icon.

t. Press the **ON** icon.

u. Press the **Exit** icon

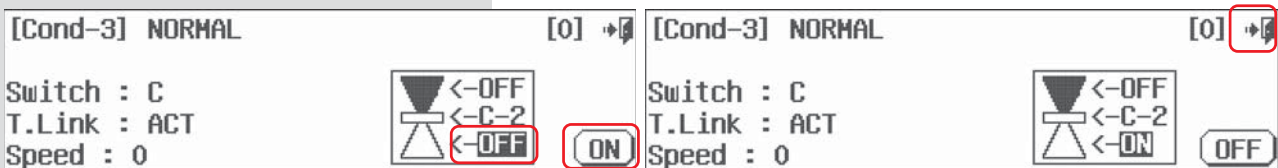

We now have programmed a NORMAL, a condition 2 and a condition 3, flight condition setting on switch C.



**FLT.COND (ACRO)**

**To set up by Switch**

Set up the Flight condition On/Off on elevator by Stick.

a. Select **SEL**



b. Select **STIC** icon

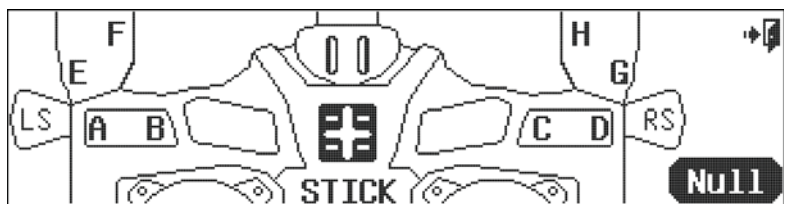

c. Select **ELEV** icon

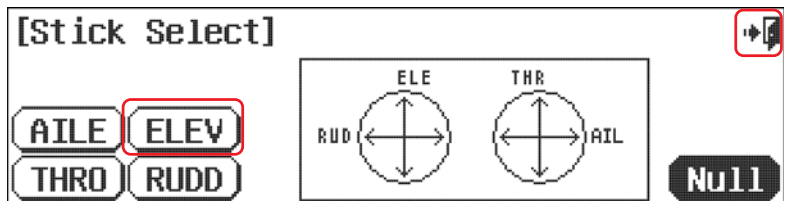

d. Select the Exit to return to the flight condition switch menu.

e. Select to move the elevator stick up and down.  
The motion is displayed as a bar graph

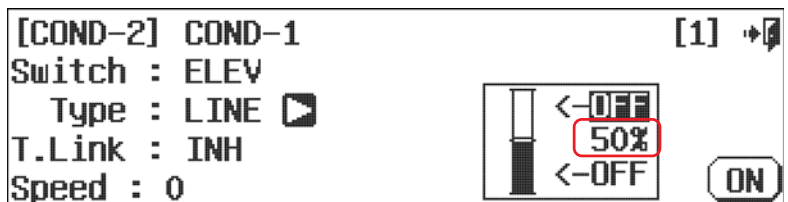

f. Select the icon of 50% bar graph

g. Stop the elevator stick in the desired position and click the Set icon.

h. Select the On icon at right bottom

i. Select the On icon at right bottom



j. Type and Speed can be selected depending on your needs.

### FLT.COND (GLID)

The Aurora 9X offers a specific flight condition menu for glider functions. While all 8 conditions are available, we have named the first 5 for the most common conditional glider functions. The following shows the switch assignments of these 5 common conditions. Please review the next sections on how to manipulate these functions.

a. Select FLT COND item on Model menu.

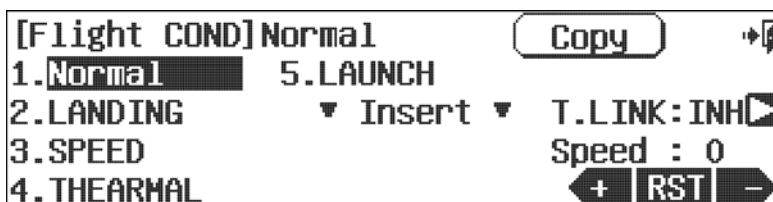

b. Press the LANDING icon and then the switch icon. We can see the the LANDING condition is on switch C.



c. Press the SPEED icon and then the switch icon. We can see the the SPEED condition is on switch E.

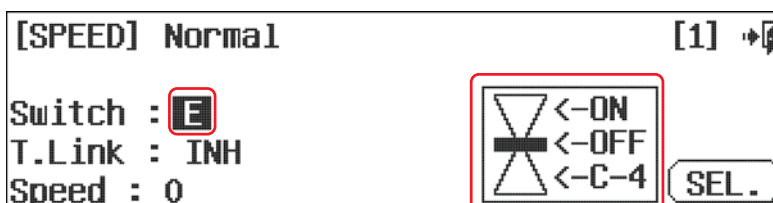

d. Press the THERMAL icon and then the switch icon. We can see the the THERMAL condition is on switch E.

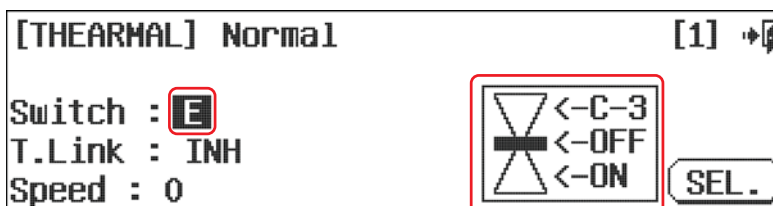

e. Press the LAUNCH icon and then the switch icon. We can see the the LAUNCH condition is on switch C.

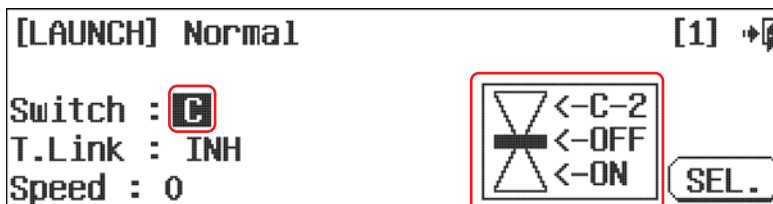

f. Double-Click the Exit icon.

**FLT.COND (ACRO and GLID)**

At this point we can choose to modify the existing flight conditions we made.

1. Change the settings and copying existing flight condition
2. Delete any of the flight conditions you made
3. Rename an existing flight condition to reflect its purpose
4. Add more flight conditions and apply them to other switches
5. Change the selected flight conditions priority
6. Decide if you want the added flight conditions to have a "trim link"
7. Add a time delay to the activation of the flight conditions

**1. Flight condition copy.**

- a. Select the master flight condition you want to copy, and click Copy.
- b. Select the Slave flight condition you want to copy(Press Insert when creating new COND)



- c. Press Yes to copy the selected flight condition.

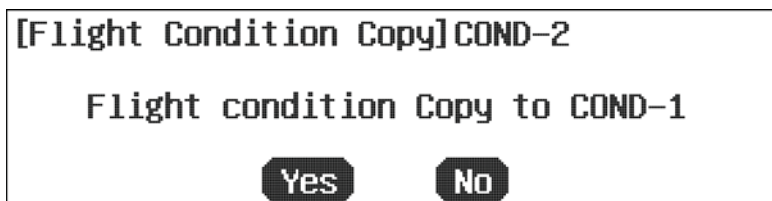

**2. Delete any of the flight conditions you made.**

- a. Select the flight condition to delete, Press Delete
- b. Press Yes to delete the selected flight condition.

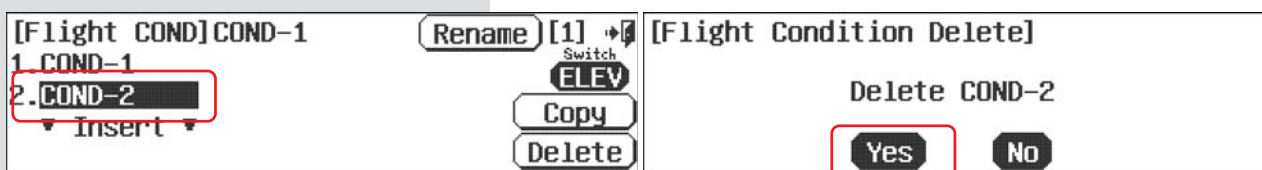

**3. Renaming an existing flight condition to reflect its purpose.**

- a. Press Cond-2
- b. Select Rename
- c. Name the flight condition to identify it with "what it does". If for example, this flight mode is for slow flight, name it "Slow Fly".
- d. Press Enter when done.



### FLT.COND (ACRO and GLID)

#### 3. Add more flight conditions and apply them to other switches.

Follow section b through k as noted previously in this section.

#### 4. Change the selected flight conditions priority

When two or more flight modes are programmed, you may change their priority by selecting the flight condition to change, and pressing the **arrow** on the Prior icon bar.

#### 5. Decide if you want the added flight conditions to have a "trim link".

To fine tune the movement values of a flight condition, you may want the trim to be changeable, or to follow the other flight modes. This is done at the T.LINK: INH arrow icon. Pressing the arrow will toggle between INH and ACT to inhibit or activate the trim link function for the selected flight condition.



Note

Trim link and condition speed can be adjusted on the flight condition list screen for NORMAL condition. Change the trim link and condition activation speed for all other flight conditions on their respective switch select screens.

#### 6. Add a time delay to the activation of the flight conditions.

Most users will desire a flight condition to be smoothly applied and retracted. Adjust the condition speed with the Speed : 0 icon using the **+RST-** icons.

### C and S, Combination and Separate "movement value" set-ups.

This is a huge feature. Take the time to understand it, as using the C and S option will expand the Aurora 9X's capability in a dramatic way.

When you have several different flight modes set-up, as you program control surface movement values into any of the following features, you can choose to have those values be associated with the C or S icon. This means:

- The C values will work in **combination** with all other features with a C value.
- The S values will work **separately** from the C value functions.

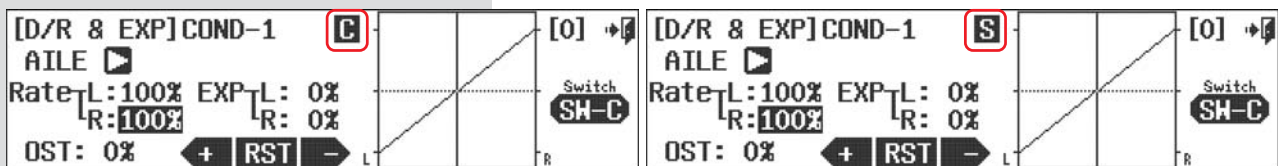

Press C to change it to S (Separately)

Press S to change it to C (Combination)



Tip

Applying the C or S option to any feature with a flight condition option, multiplies the capability of the Aurora. The default for all features will be the C values. As with most of the Auroras features, experimentation is encouraged as experience is truly the best teacher.

## Spoiler (GLID)

### Spoiler Function and Landing Mode.

The Spoiler function will be used for a switch to deploy a spoiler flight surface.



Note

- This function is to be programmed on a switch. It is on, or off. For progressive, proportional deployment of an airbrake with a slider control, use the spoiler to Elevator function on page 92.
- If you program the airbrake function on a switch in this menu, the Airbrake to Elevator function mix progressive airbrake deployment feature will not work.
- If your model does not have an airbrake, this function can be applied separately to the ailerons, elevator and flaps to move them to a "spoileron", "crow"/"butterfly" and other creative flight control positions with the selection of a switch.

- During the model type set-up in the system menu, select **Spoiler** if your model is to use an airbrake. This will apply the airbrake to a channel within the model's program.

a. Select **Spoiler** from the model menu.



b. Press the **ACT** icon to enter the Spoiler menu.



### Switch Option

d. Press **NULL** to apply the Spoiler activation to a two position switch.

Switch type	Function
2 positions	On or Off

e. The Spoiler can mix with other Functions. Put the value of Speed and Delay by using **+RST-** icon and then proceed to set on the Off position.

f. Select a **Speed** value to have the Spoiler deploy over a selected period of time.

g. Press the **Exit** icon to go back to the model menu.

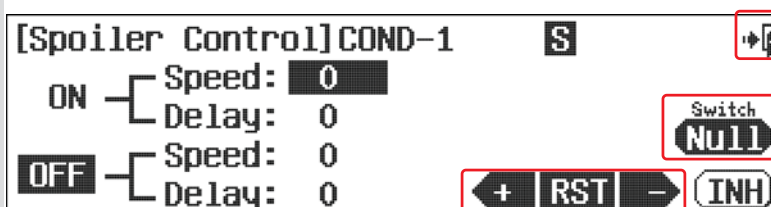

### SPO-ELE (GLID)

#### Spoiler to Elevator Mix.

Spoiler to elevator mix is used to progressively deploy a Spoiler and/or a landing configuration. The elevator compensation will counter the pitching of the aircraft when an airbrake is deployed. The default is the spoiler on the RS(right slider) control.



This function will not work if you have the Airbrake function already programmed on a switch as described in the Airbrake function section.

#### Apply the spoiler to a control

a. During the model type menu set-up you should have selected spoiler as a model function. Airbrake needs to be applied to a control, we suggest the right slider or RS control.

b. From the home screen, press the **Airbrake System menu (wrench)** icon.

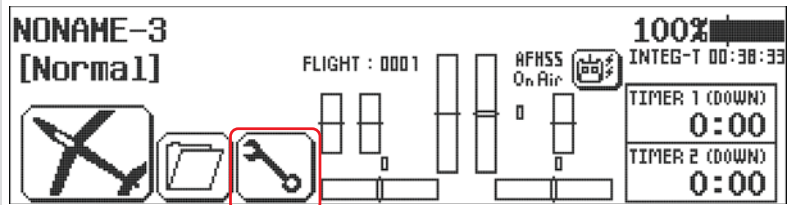

c. Select **Channel**.

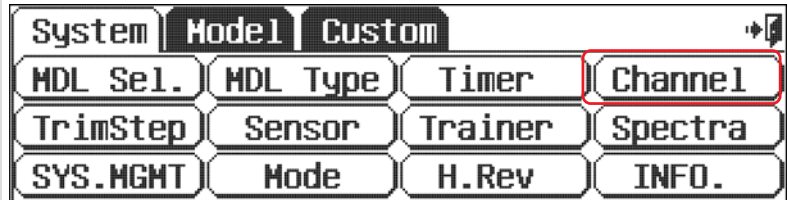

d. Press SPO : **NULL**.

e. Press **SEL**.

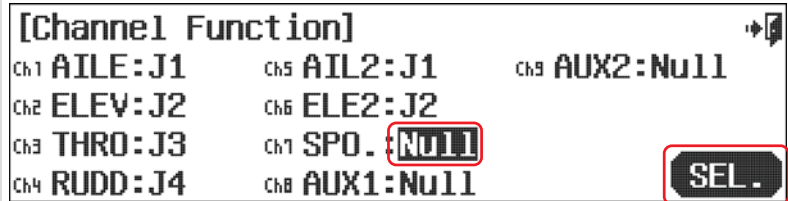

f. Select **RS**.

g. Press **SET**.

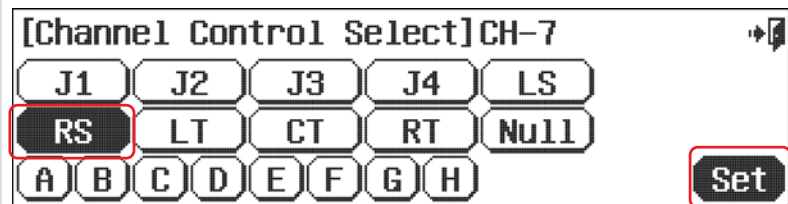

h. Back at the channel function menu, press the **Exit** and return to the system menu.

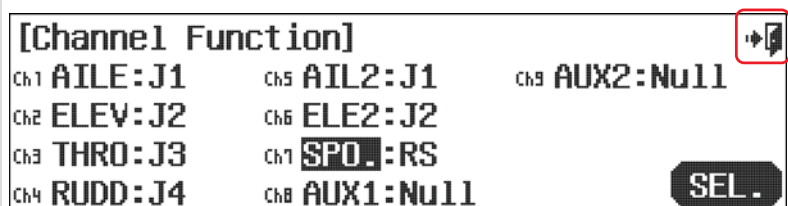

**SPO-ELE (GLID)**

**Program a Spoiler to Elevator mix**

i. Select the **SPO-ELE** function icon from the model menu.

j. Press **ACT** to access the menu screen.



k. The Aurora 9X offers a 7 point curve on many of our adjustable mix menu items. To adjust the travel values, move the corresponding control stick or slider to align the moving line with the point you wish to adjust. Press the + or - icon to adjust to the desired curve points. If you wish to inhibit any curve points, press the RST icon. It is necessary to inhibit the #2, 3, 5 and 6 points, and to just adjust points 1 and 7 equally to achieve a linear curve.

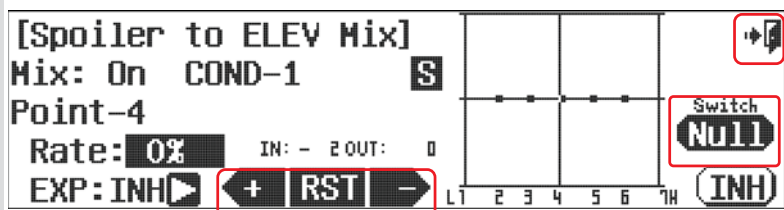

l. Press the **Exit** icon to exit back to the model menu.

**Switch Option and In-Flight Fine Trim Adjustment Switch Function**

m. To select a switch that will turn the mix on and off and to select an "in-flight" ADJUSTMENT switch, press **NULL** and follow the switch activation process.

Switch type	Function	VR adjustment
2 position	On or Off	Fine tuning control choice



### AIL-RUD (ACRO and GLID)

#### Aileron to Rudder Mix.

Provide your large scale aircraft or sailplane with an aileron to rudder mix for smooth, coordinated turns.

### This function can be influenced by the flight condition feature ###

a. Select the AIL-RUD icon from the model menu.

b. Press ACT to access the mix menu screen.



#### Switch Option and In-Flight Fine Trim Adjustment Switch Function

c. To select a 2 position switch that will turn the mix on and off, select an "in-flight" ADJUSTMENT switch, and choose to activate the trim link feature, press NULL and follow the switch activation process.

Switch type	Function	Trim link	VR adjustment
2 position	On or Off	Yes, T.APP	Fine tuning control choice

d. The Aurora 9X offers a 7 point curve on many of our adjustable mix menu items. To adjust the travel values, move the corresponding control stick or slider to align the moving line with the point you wish to adjust. Press the + or - icon to adjust to the desired curve points. If you wish to inhibit any curve points, Press the RST icon. It is necessary to inhibit the #2, 3, 5 and 6 points, and to just adjust points 1 and 7 equally to achieve a linear curve.

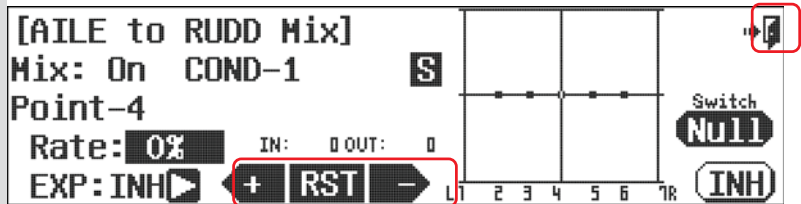

e. Press the Exit icon to return to the model menu.

**ELE-CAM (ACRO and GLID)**

**Elevator to Camber Mix.**

The elevator to camber mix allows the model to drop and raise the entire trailing edge of your models wing control surfaces as the elevator is used.

As in many of the Aurora 9X's model menu options, there are several airframe variables that are selected and appear in the different menu screens. In the case of the elevator to camber mix, the number of flaps and ailerons will appear as a variable based on the airframe type you told the radio you had at the time of initial model set-up in the system menu.

**### This function can be influenced by the flight condition feature ###**

a. Select **ELE-CAM** from the model menu.

b. Press **ACT** to activate the mix.



**Switch Option and In-Flight Fine Trim Adjustment Switch Function**

c. To select a 2 position switch that will turn the mix on and off, select an "in-flight" ADJUSTMENT switch, and choose to activate the trim link, press **NULL** and follow the switch activation process.

Switch type	Function	Trim link
2 position	On or Off	Yes. T.APP

d. The Aurora 9X offers a 7 point curve on many of our adjustable mix menu items. To adjust the travel values, move the corresponding control stick or slider to align the moving line with the point you wish to adjust. Press the + or - icon to adjust to the desired curve points. If you wish to inhibit any curve points, press the RST icon. It is necessary to inhibit the #2, 3, 5 and 6 points, and to just adjust points 1 and 7 equally to achieve a linear curve.

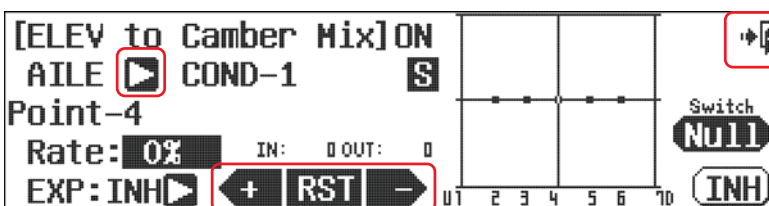

e. Click the arrow icon to set the values of the flap (If flap exists).

f. Again use the **+RST-** icon to set the value for the flaps. Note the flaps will only appear as an option if you told the radio your model had flaps when it was set up.

g. Select the **Exit** icon to return to the model menu.

### RUD-AIL (ACRO and GLID)

#### Rudder to Aileron Mix.

If you wish to mix aileron into a rudder input, follow the directions below.

### This function can be influenced by the flight condition feature ###

a. Select **RUD-AILE** from the model menu.

b. Press the **ACT** icon to enter the rudder to aileron mix.



#### Switch Option and In-Flight Fine Trim Adjustment Switch Function

c. To select a 2 position switch that will turn the mix on and of, select an "in-flight" ADJUSTMENT switch, and choose to activate the trim link, press **NULL** and follow the switch activation process.

Switch type	Function	Trim link
2 position	On or Off	Yes. T.APP

d. After moving to the desired position with the rudder stick, the aileron control value that has been changed using the -Rst+ icon is displayed in the graph.

g. Press the **Exit** icon to exit back to the model menu.

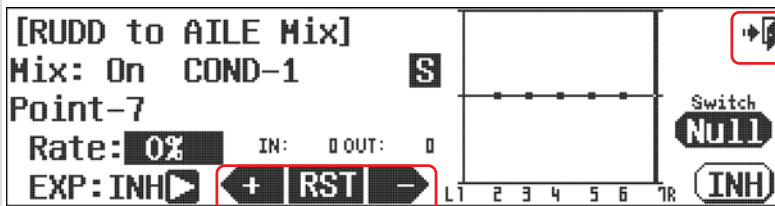

## AIL DIFF (ACRO and GLID)

### Aileron Differential.

Aileron differential is generally used to provide more up aileron, than down aileron travel. This will help prevent adverse yaw conditions when banking and rolling the aircraft.

**### This function can be influenced by the flight condition feature ###**

a. Select the **AIL DIFF** icon from the model menu.

### Switch Option and In-Flight Fine Trim Adjustment Switch Function

b. To select a 2 or 3 position switch that will allow multiple differential values to be used, turn the feature on and off, and to select an "in-flight" ADJUSTMENT switch, press **NULL** and follow the switch activation process.

Switch type	Function	Trim link
2 position	On or Off	Yes. T.APP

c. Select the aileron and the travel direction limit..

d. Input a value with the **+RST-** icon.

e. Press the **Exit** icon to return to the model menu.

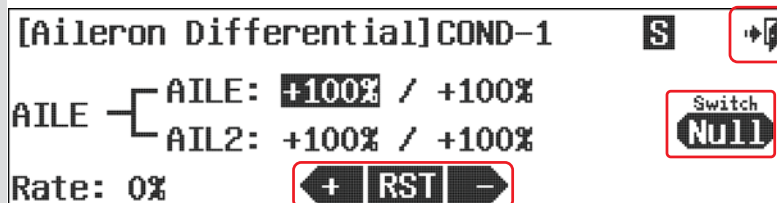

- A value that equates to 50% "down" aileron travel compared to 100% of the "up" aileron travel is a good place to start.
- Use the ADJUST feature described in the switch set-up process to make fine in-flight adjustments.

### AIL- FLP (ACRO and GLID)

#### Aileron to Flap Mix.

Aileron to flap mix can be set up to allow the full trailing edge of the wing (flaps and ailerons) to move together, acting as one large aileron on each wing panel.

### This function can be influenced by the flight condition feature ###

a. Select the **AIL-FLP** icon in the model menu.

b. Select **ACT** to activate the feature.



#### Switch Option and In-Flight Fine Trim Adjustment Switch Function

c. To select a 2 position switch that will turn the mix on and off, select an "in-flight" ADJUSTMENT switch, and to apply a trim link, press **NULL** and follow the switch activation process on page 68.

Switch type	Function	Trim link	VR adjustment
2 position	On or off	Yes, T.APP	Fine tuning control choice

d. The Aurora 9X offers a 7 point curve on many of our adjustable mix menu items. To adjust the travel values, move the corresponding control stick or slider to align the moving line with the point you wish to adjust. press the + or - icon to adjust to the desired curve points. If you wish to inhibit any curve points, press the RST icon. It is necessary to inhibit the #2, 3, 5 and 6 points, and to just adjust points 1 and 7 equally to achieve a linear curve.

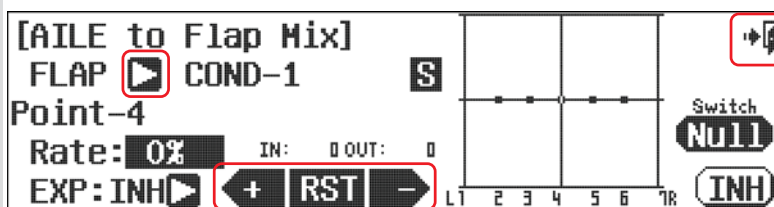

e. Click the arrow icon to set the values of the flap 2 (If flap 2 is existed)

f. Select the **Exit** icon to return to the model menu.

**CAMBMIX (ACRO and GLID)**

**Wing Trailing Edge Camber Mix.**

Mix the ailerons, flaps and elevator onto an Aurora control with the Camber mix feature.

Provide one switch or variable control to lower and raise the trailing edge while using elevator compensation.

**### This function can be influenced by the flight condition feature ###**

a. Select the **CAMBMIX** icon from the model menu.

b. Press **ACT** to activate the Camber mix menu.



c. The first decision is where to place the camber mix function control. We suggest the default of the RS (right slider) to begin with. You can change it later if you wish by selecting the **arrow** on the top line of the screen and selecting another control for the camber mix.

**Switch Option and In-Flight Fine Trim Adjustment Switch Function**

d. To select a 2 position switch that will turn the mix on and off and to select an "in-flight" ADJUSTMENT switch, press **NULL** and follow the switch activation process.

Switch type	Function	VR adjustment
2 position	On or Off	Fine tuning control choice

e. The Aurora 9X offers a 7 point curve on many of our adjustable mix menu items. To adjust the travel values, move the corresponding control stick or slider to align the moving line with the point you wish to adjust. Press the + or - icon to adjust to the desired curve points. If you wish to inhibit any curve points, press the RST icon. It is necessary to inhibit the #2, 3, 5 and 6 points, and to just adjust points 1 and 7 equally to achieve a linear curve.

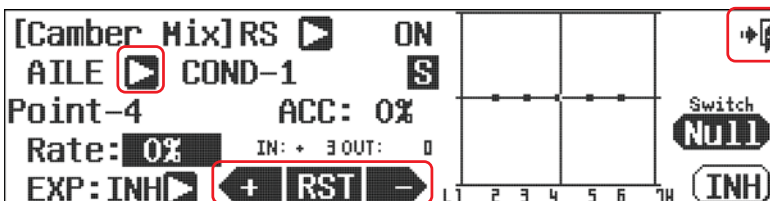

f. Input a movement value using the **+RST-** icon.

g. Repeat this process until the ailerons, flaps and elevator flight control channels all move where you want them too.

h. Select the **Exit** icon to return to the model menu.



The Camber Mix feature has a second screen in the adjustment menu allowing you to set adjustment travel rate values for all the different control surfaces.

### FLP CON (ACRO and GLID)

#### Flap to Elevator Mix.

Flap Control will mix the elevator into any flap movement to avoid pitch changes as flaps are deployed.

### This function can be influenced by the flight condition feature ###

a. Select the **FLP CON** icon from the model menu.

b. Press **ACT** to activate the Flap Control menu.

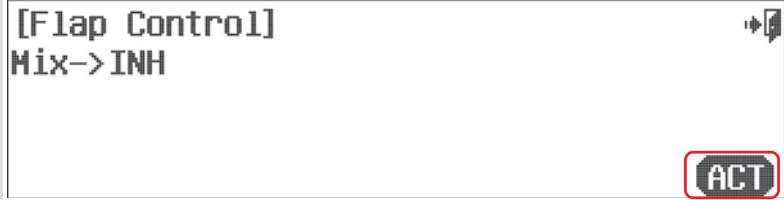

#### Switch Option and In-Flight Fine Trim Adjustment Switch Function

c. To select a 2 or 3 position switch that will allow multiple mix values, select an "in-flight" ADJUSTMENT switch, press **NULL** and follow the switch activation process.

Switch type	Function	VR adjustment
2 or 3 position	On or off	Fine tuning control choice

d. The Aurora 9X offers a 7 point curve on many of our adjustable mix menu items. To adjust the travel values, move the corresponding control stick or slider to align the moving line with the point you wish to adjust. press the + or - icon to adjust to the desired curve points. If you wish to inhibit any curve points, Press the RST icon. It is necessary to inhibit the #2, 3, 5 and 6 points, and to just adjust points 1 and 7 equally to achieve a linear curve.

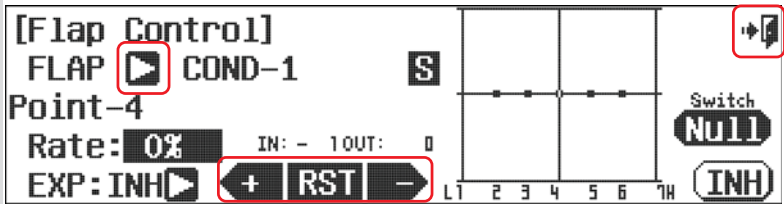

e. Click the arrow icon to set the values of the flap 2 (If flap 2 exists).

f. Note the addition of the elevator as the flap control is moved.

g. Select the **Exit** icon to return to the model menu.



**FLAPTRIM (ACRO)**

**Flap Trim Mix.**

Typically, the function of flap trim is used to fine tune the up/down the two flaps.

a. Select the **Flap Trim** icon from the model menu.

b. Press **ACT** to activate the Flap trim menu.

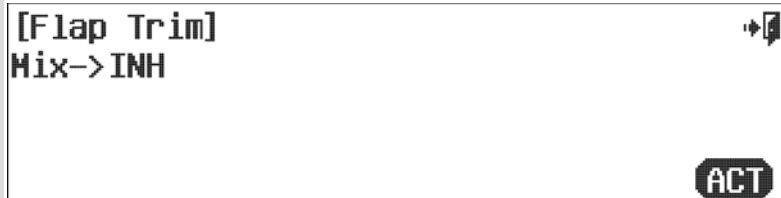

c. After selecting the desired flap movement, put the appropriate value by using +Rst-.



d. The switch set is possible by LT, CT, RT, and T-3.

f. Select the **Exit** icon to return to the model menu.

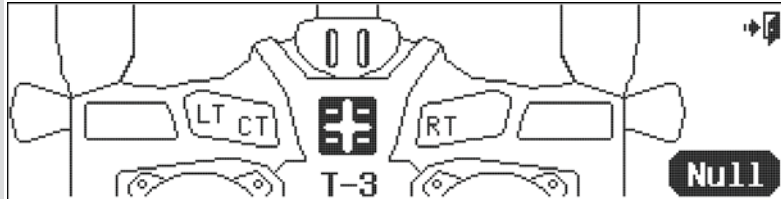

### V.Tail (ACRO and GLID)

#### V.Tail Set up

Aircraft with a V tail can use this function to limit the travel of the tail control servos up, down or both directions.



It is not necessary to access or change this menu to fly a V tail aircraft. The default values are 100% movement in all directions.

### This function can be influenced by the flight condition feature ###

To change the end points on the V-tail servos while they are performing the rudder and elevator functions:

a. Select V. Tail from the model menu.

b. The first screen allows adjustment of the elevator function. Select the control and direction you wish to change.

c. Press the **+RST-** icon to change the rate values for the elevator servo as it performs the elevator and rudder control functions. Repeat the process for all values on this menu page you want to change.

d. Press the **1/2** icon to access the next page containing the same adjustment format on the rudder control surfaces.

e. Change the rate values for the rudder servo as it performs both the rudder and elevator control functions. Repeat for all values on this page you want to change.

f. Press the **Exit** icon to back out to the model menu.

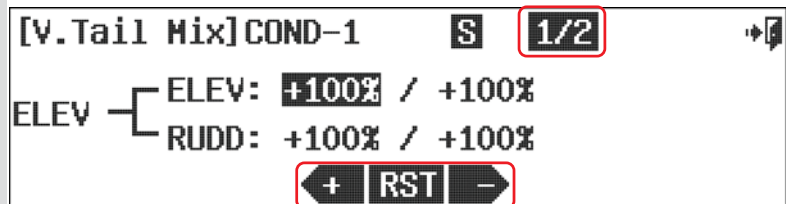

## AILEVATOR (ACRO and GLID)

### Split Elevator and Aileron Mix Controls.

The ailevator feature allows the adjustment of a two servo or split elevator. It also features an “aileron to split elevator” mix so when ailerons are applied, the elevators move in opposite directions. This is useful for advanced “taileron” aircraft, notably jets.

### This function can be influenced by the flight condition feature ###

a. Select **AILEVATOR** from the model menu. The #1 Ailevator screen is for ailerons

b. There are two screens, the first to adjust the amount of elevator movement to be applied when the ailerons are moved.

c. Press the **1/2** fraction icon to move to the second menu screen.

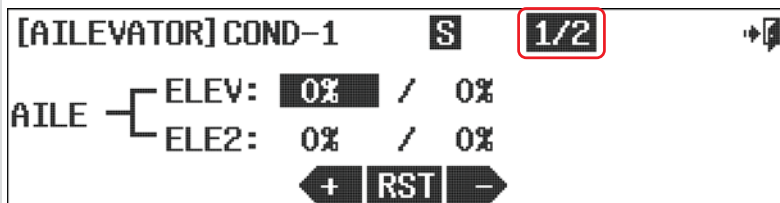

d. The second screen is for the elevator servo movement. This effectively sets the end points for the elevator servos.

e. Select between the screens and servos to apply the rate values you want your model to use.

f. Select the **Exit** icon to return to the model menu.

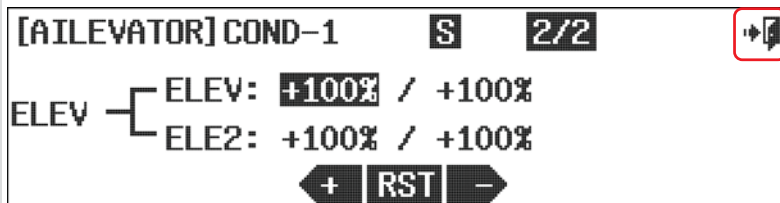

### Elevon (ACRO and GLID)

#### Flying Wing Mix.

Flying wing aircraft will most often be set up using elevons. The Aurora 9X mixes the aileron and elevator functions to provide these controls in just one flight control surface per wing panel.



It is not necessary to access or change this menu to fly a flying wing aircraft. The default values are 100% movement in all directions.

### This function can be influenced by the flight condition feature ###

To change the end points on the elevon servos while they are performing the aileron and elevator functions:

a. Select **Elevon** from the model menu.

b. The first screen allows adjustment of the aileron function. Select the control and direction you wish to change.

c. Press the **+RST-** icon to change the value. Repeat for all rate values on this page you want to change.

d. Press the **1/2** icon to access the next page containing the same adjustment format on the elevator control function.

e. Change the values on this page to obtain the results you require.

f. Press the **Exit** icon to back out to the model menu.

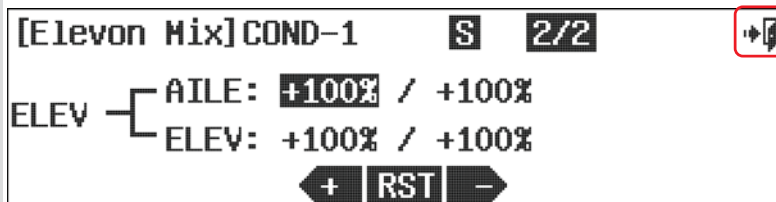
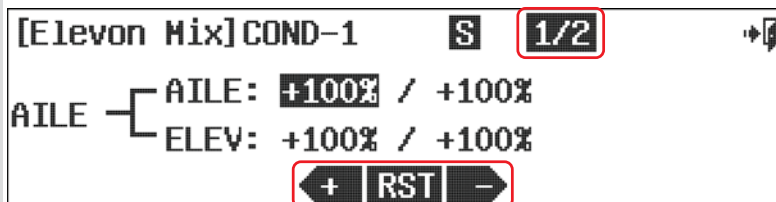

## Thro.Cut (ACRO)

### Throttle Cut Position.

Many would agree a throttle cut function is required to safely fly glow and gas aircraft. The Aurora 9X's throttle cut feature will bring the throttle servo to a programmed position allowing the motor to drop to low idle or to kill the power entirely. It's your choice as to how you program it.

a. Press **Thro. Cut** in the model menu. Throttle Cut activation screen

b. Press **ACT** to activate the throttle cut menu.

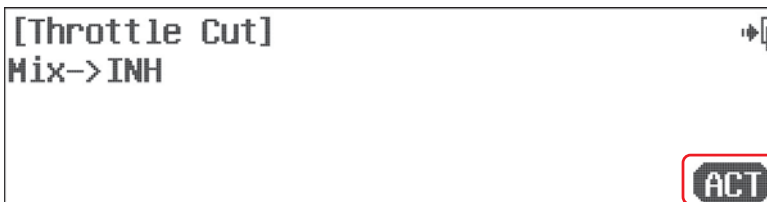

### Switch Select

c. To select a switch that will allow you to activate the throttle cut function, select an "in-flight" ADJUSTMENT switch, and to link the throttle trim to the switched throttle cut feature, press **NULL** and follow the switch activation process. Normally throughout the Aurora manual, we don't recommend a switch location. However, to trigger the throttle cut feature we believe the "dead man" switch H is the most practical location for the throttle cut switch.

Switch type	Function	Trim link	Cut position
2 position	On or Off	Yes, Adjust to trim	Cut control choice

d. Bring the throttle stick down to slightly below 1/2 stick.

e. While holding switch H forward so the throttle cut is activated, carefully apply a rate value to the **RATE : 0%** using the **+RST-** icon. Watch the servo arm movement direction to see if a + or - value is required to lower the throttle to a position that will "kill" the engine. Do this slowly and make sure the throttle linkage does not bind and stall the servo. Often a manual adjustment to the carburetor "idle stop" is necessary.



f. Press the **Exit** icon to go back into the model menu.



The default throttle cut position is below 1/2 stick. Change this cut position with the throttle cut feature explained in the switch section.

### T.Curve (ACRO)

#### Throttle Curve Adjustment.

The throttle curve function allows you to modify the normally linear servo rate movement using seven different points along the curve that can accept a movement value.

There are many options for the throttle curve feature. It can be one of the most complicated features of the Aurora 9X. You can choose to use many or as few of the functions on this menu as you wish too.

### This function can be influenced by the flight condition feature ###

a. Press **T. Curve** in the model menu.

b. Press **ACT** to activate the throttle curve menu.



#### Switch Option

c. To select a 2 or 3 position switch that will allow multiple mix values, press **NULL** and follow the switch activation process.

Switch type	Function	VR adjustment
2 or 3 position	Multiple Values	Fine tuning control choice

- Note how the throttle movement is shown on the graph as a percentage value, when the throttle is advanced and lowered.

d. The point is created after pressing **RST** in the desired position by Throttle stick movement. If created point is changed. If you want to change the corrected point, adjust the **+RST-** icon while the throttle is positioned on the point..

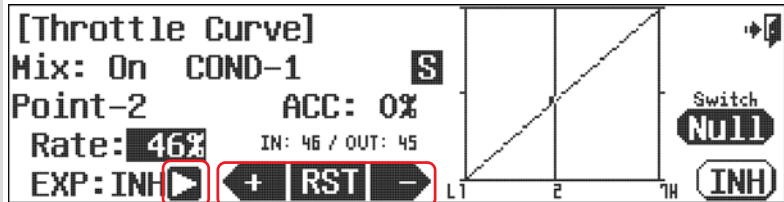

e. Inhibit (turn off), or activate (turn on) a point by using the throttle to place the graph line through the point you wish to change, press **+RST-**.

f. Add an exponential curve from one point to another by pressing the **arrow** next to the **EXP: INH** icon and have it switch to **EXP: ACT**. This activates the expo option between it, the prior and the next point. Use the **+RST-** icons to add a value creating a curve.

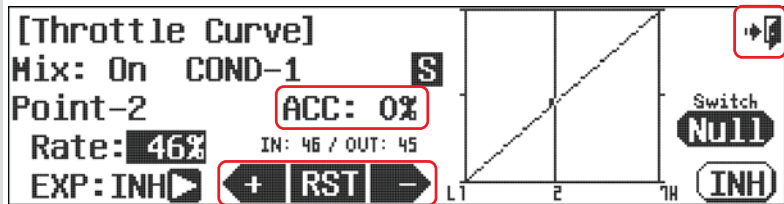

g. Change the activation speed with the **ACC** or acceleration feature. Again, using the throttle to place the graph line through the point you wish to change.

h. Select the **Exit** icon to return to the model menu.

**Idle Down (ACRO )**

**Idle Adjustment.**

The Idle Down function will apply a rate value to the throttle channel raising or lowering the throttle to a position determined by the user when a switch is activated. This position will become the low throttle point for as long as the switch is selected.

a. Select **Idle Down** from the model menu.

b. Press **ACT** to activate the idle down function menu.



**Switch Option**

c. To select a two position switch that will activate the idle down feature and a throttle trim link, press **NULL** and follow the switch activation process.

Switch type	Function	Trim link
2 position	On or Off	Yes, Adjust to trim

d. Using the **+RST-** icons, set the throttle down position desired. A positive value will be "above", while a negative value "below", the "normal" low throttle stick position.

e. Press the **Exit** icon to return to the model menu.





### B-fly (GLID)

#### Butterfly or Crow Mix.

Butterfly, also known as “Crow” mixing is used to land slippery gliders easier and with greater accuracy. The mix is usually activated with the linear action of the throttle stick which drops the flaps, raises the ailerons and employs a bit of up elevator to compensate for the pitch down created by all the additional control surface drag.

### This function can be influenced by the flight condition feature ###

a. Select **B-Fly** from the model menu.

b. Press **ACT** to activate the Butterfly control feature menu.



#### Switch Option

c. Select a 2 position switch and/or the throttle stick to activate the butterfly mix. Choose a “cut” point if you wish, and apply an in flight adjustment switch by pressing **NULL** and following the switch activation process.

Switch type	Function	Cut Function	VR adjustment
2 position and/or throttle	Variable function	Cut control choice	Fine tuning control choice



We suggest you choose the throttle, **THR**, as the “switch” activating the mix. This gives a linear, progressive deployment and retraction of the flight control surfaces.

d. Use the **+RST-** icon to set a movement value for the aileron, elevator and flaps. Move the throttle stick to see the effect of the movement values you selected for the flight control surfaces.

e. Select the **Exit** icon to return to the model menu.

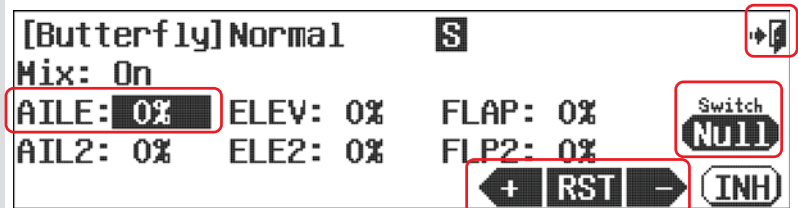

## SnapRoll (ACRO)

### Automatic Snap-Roll Function.

The Snap-Roll feature will allow you to program an aileron, elevator and rudder travel rate for inside and outside snap rolls in either the right or left direction.

### This function can be influenced by the flight condition feature ###

There are four snap types the Aurora 9X can be programmed for;

R/U= right, inside snap

L/U= left, inside snap

R/D=right, outside snap

L/D=left, outside snap

### There are two ways to accomplish the snap roll programming.

1. The **Single**, programming a master switch (usually H) for one snap "type".
2. The **Multi**, programming a master switch (usually H) to activate the programming for two or more snap types that are programmed on other switch positions.

For clarity, we will review the method to place one snap roll function on one switch using the Single option, then show how to program several switches for different snap rolls using the Multi option.

### The Single Snap Roll Option

a. Select SnapRoll from the model menu. Snap-Roll activation screen

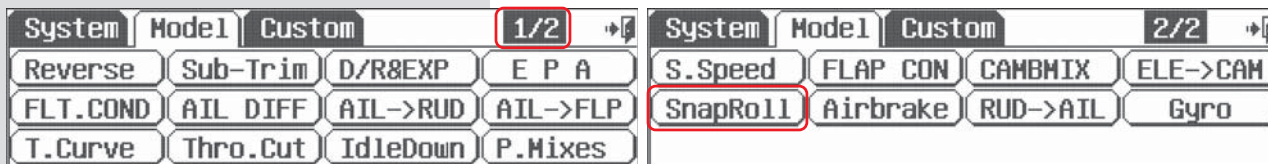

b. Press **ACT** to activate the Snap Roll function menu.



### Select a master snap roll switch

c. To select a switch that will allow you to activate the snap roll feature press **NULL** and follow the switch activation process.

Normally throughout the Aurora 9X manual we don't recommend a switch location. However, to trigger the snap roll feature we believe the "dead man" switch **H** is the most practical location for the snap roll master switch function.

Switch type	Function
2 position	On or Off

### SnapRoll (ACRO)

d. Press the **arrow** icon next to Direction.

e. Choose a snap "type" R/U for right inside, L/U for left inside, R/D for right outside and L/D for left outside.

f. Select the control to adjust, AILE, ELEV, OR RUDD.

g. Add a movement rate value with the **+RST-** icons

h. Repeat the process for all the controls.

i. By flipping the switch you choose for the snap roll feature, you can see the movement on your aircrafts control surface. Be prepared to make minor adjustments to your control movement rate values after flying and using the snap roll feature

j. Press the **Exit** icon to return to the model menu.



### Multiple Snap Roll functions on multiple switches

a. Select SnapRoll from the model menu.

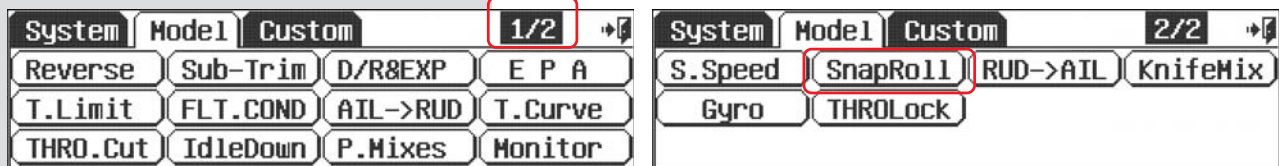

b. Press ACT to activate the Snap Roll function menu.



### Select a Master Snap Roll Switch

c. To select a switch that will allow you to activate the snap roll feature press **NULL** and follow the switch activation process. Normally throughout the Aurora 9X manual we don't recommend a switch location. However, to trigger the snap roll feature we believe the "dead man" switch **H** is the most practical location for the snap roll master switch function.

Switch type	Function
2 position	On or Off

d. Press the **Single** icon, it will change to **Multi**.



### SnapRoll (ACRO)

e. Choose a snap "type" R/U for right inside, L/U for left inside, R/D for right outside and L/D for left outside.

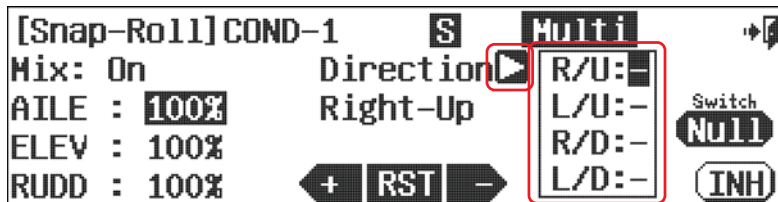

f. Select a switch for the snap type you selected. Note the switch you selected appears on the direction part of the screen associated with the snap type you wanted.

Switch type	Function
2 or 3 position	On or Off

g. Select the control to adjust, AILE, ELEV, OR RUDD.

h. Add a movement rate value with the +RST- icons.

i. Repeat the process for all the controls used in the snap.



j. Flip the switch you choose for the snap roll type you selected, now trigger the master H switch, your aircraft controls should move in relation to the snap type you choose. Be prepared to make minor adjustments to your control movement values after flying and using the snap roll feature.

k. To add another snap type, repeat steps, e thru j.

l. Press the Exit and return to the model menu.

### Knife Edge Mix(ARCO)

#### Knife Edge Mix

This mixing is helpful function on flight when operating Knife function more easily.

### This function can be influenced by the flight condition feature ###

a. Select Knife Edge Mix from the model menu.

b. Press ACT to activate the Knife Edge Mix function menu.

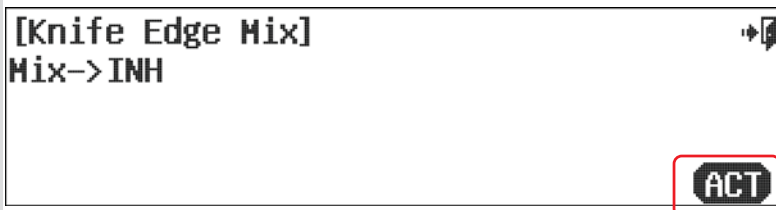

#### Switch Option

c. To select a 2 or 3 position switch that will allow multiple mix values, press NULL and follow the switch activation process.

Switch type	Function	VR adjustment
2 or 3 position	On or Off	Fine tuning control choice

d. Put the setting values of Aileron and Elevator by using +Rst- icon.

e. Check the On/Off position of selected mixing switch.

f. Select the Exit icon and return to the model menu.

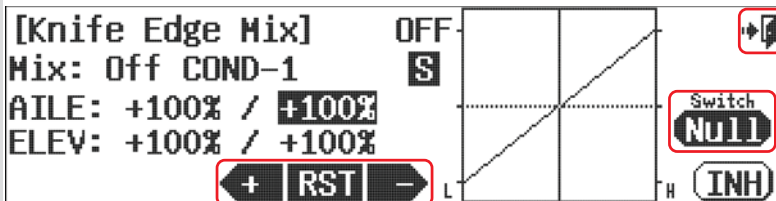

## Motor (GLID)

### Motor Control Menu.

Use the motor function available in the GLID programming to turn an electric motor on or off using a two position switch.

### This function can be influenced by the flight condition feature ###

a. Select Motor from the model menu.

b. Press ACT to activate the Motor Control feature menu.



### Switch Option

c. To select a 2 position switch that will start and stop the motor, press NULL and follow the switch activation process.

Switch type	Function	Trim link
2 position	On or Off	Yes, Adjust to trim

d. Using the +RST- icons, set the motor speed and delay values for both the "turning on and off functions. Use the switch you selected to move between on and off.

e. Press the Exit icon to return to the model menu.

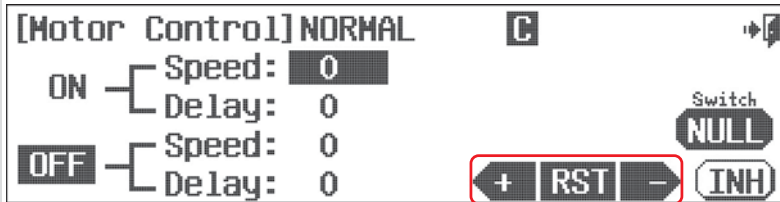

Note

Both speed and delay values are in 0.1 second steps.

### Launch (GLID)

#### Glider Launch Menu.

The Launch mix allows the aileron, flap and elevator functions to be mixed and deployed by selecting a switch. As the name implies, it is used to optimize the entire trailing edge of the wing for a launch mode. Try to drop the trailing edge a couple of degrees and add up elevator compensation on gliders for a better zoom launch configuration.

### This function can be influenced by the flight condition feature ###

- a. Select Launch from the model menu.
- b. Press **ACT** to activate the Launch feature menu.



#### Switch Option

- c. Select a 2 position switch that will activate the launch mix, create a "cut" point, and apply an in flight adjustment switch. Press **NULL**.

Switch type	Function	Cut Function	VR adjustment
2 position	On or Off	Cut control choice	Fine tuning control choice

- d. Use the **+RST-** icon to set a movement value for the aileron, elevator and flaps.
- e. Select Speed: 0, and change the time value with the **+** icon to set a delayed control deployment speed.
- f. Check the On/Off by SW C set as initial value in the glider
- g. Select the **Exit** icon and return to the model menu

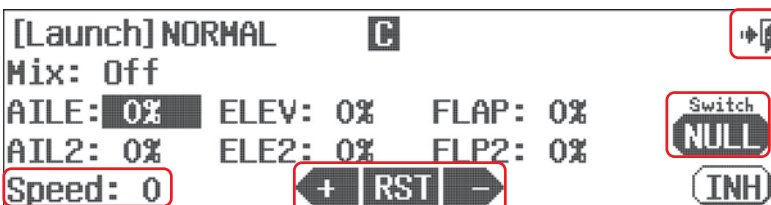

The "Cut" function for the launch mode is different than any other cut function in the Aurora 9X.



## Offset (GLID)

### Offset Menu.

This Offset is a function to fine-tune the aileron, elevator, and flap when using Glider.

### This function can be influenced by the flight condition feature ###

a. Select Offset from the model menu.

b. Press **ACT** to activate the Offset feature menu.



c. Put the appropriate value by using **+RST** - after 3 selecting the channel that you want to set.

d. Select the **Exit** icon and return to the model menu.

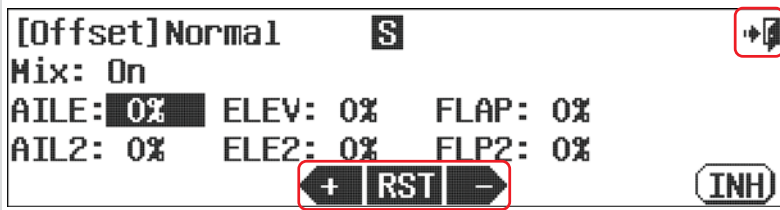

## Model Menu - HELI Specific Functions

The Aurora 9X offers a rich selection of features to fly everything from the simplest to very complex and sophisticated helis.



Tip

To the heli owner using this manual for the first time it is recommended you proceed through the following material contained in this manual:

1. Section one introductory information
2. Section three, the heli quick start guide
3. Section four, the system menu
4. Section five, common features of all model types

After setting the heli up in the Aurora 9X system menu through the MDL. Sel. feature as described in section two, visit section five for all the basic set-up functions, then skip back to this section for the rest of the information.

The following Aurora 9X features are specific to heli aircraft:

Flight Conditions	Flight conditions or Idle-Up menu
P. Curve & T. Curve	Rotor blade pitch curve and Throttle curve adjustment
SWH->THR	Swash plate movement to throttle mix
RUD->THR	Tail rotor to throttle mix
T. HOLD	Throttle hold function
SwashMix	Swash plate fine tuning menu
REVO Mix	Revolution mix
Gyro	Gyro sensitivity control menu
Governor	RPM governor adjustment

These additional set-up functions are defined earlier in the manual.

EPA	End Point Adjustment
D/R & EXP	Dual Rates and Exponential (expo) rates
Sub-Trim	Servo Sub-trim adjustment
Reverse	Servo reversing function
S. Speed	Servo Speed feature
Monitor	Active model control monitor
P. Mixs	Programmable Mixing

\*\*\*\*\* IMPORTANT PROGRAMMING TIPS \*\*\*\*\*

**Throttle Lock**

The Aurora 9X features a "throttle lock" function that can be activated when the transmitter is transmitting a signal. We encourage you to apply the throttle lock as a safety precaution against "accidental throttle application".

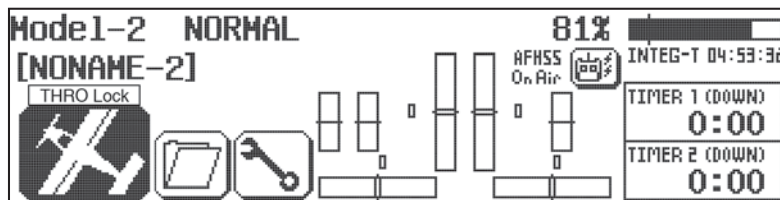

- a. Turn the throttle lock on and off from the home page by pressing the **Model** icon for two seconds. Throttle lock is confirmed when the "THRO Lock" icon is displayed.

**Reset, the best hint of all**

As you program a model into any computer radio, especially one as sophisticated as the Aurora 9X, it is easy to make a mistake. If "things" just are not working the way they should, start over. There are thirty model memories in the Aurora 9X. Start a new model or Reset the current one in the System-MDL Sel. menu. You will lose all the programming you have done for that model up to that point, but starting over is the best "cure" for 90% of all "problems" modelers have with programming issues.

With very complex models, it would be wise to "save" a programming sequence by periodically using the Copy option in the model select menu.

**Switches**

The functions that you program into the Aurora 9X will be "on" all the time, noted as NULL on the specific features menu screen. All these features can be toggled on or off using a two position switch, or several different values can be applied to some features using three position switches. While still other functions like Camber are applied to a slider and their movement dialed-in as needed. All these different methods for selecting and formatting switches and other control functions are described on page 68 in the manual rather than being repeated throughout the document on every other page.

**Flight conditions or Idle-Up**

Idle-up is a function of the flight condition feature. The Aurora 9X programming offers the use of one "normal", four "idle-up" modes and a hold condition. Use the flight condition feature to apply different rate values for the gyro, governor, pitch and throttle curves, and most other critical functions within each "condition". As you travel the Aurora learning curve, we encourage you to explore how the flight condition/Idle-up function can influence almost every feature of the Aurora. Of major note will be the C (combined) and S (separate) options that deliver an almost infinite number of programming combinations.

**Selecting a Servo or Channel to Adjust the Value**

There are three ways to select a servo to adjust;

- Use the control stick to make the adjustment. Right and left, up and down to select the direction you want to adjust. This way you see the results of your input if the aircraft is turned on.
- Press the % value icon for any single servos one direction.
- Press the **name** icon of the control to be adjusted and adjust both directions at the same time.

**3 Axis Control Definitions**

Within the Aurora 9X programming, you will see the fixed wing generic terms for our traditional 3 axis heli control functions.

- Elev = Pitch
- Aile = Roll
- Rudd = Yaw or tail rotor control

### FLT.COND (HELI)

#### Flight Conditions, Idle-Ups and Throttle Hold.

When a heli aircraft is selected as the active model, the flight condition function becomes the heli idle-up and throttle hold feature.

There are 8 flight conditions:

- Normal
- Idle-up 1-4
- Throttle hold
- Two open conditions, condition 7 and 8.



Note

You are not obligated to use the flight condition / idle-up feature to fly a heli.

The following Aurora 9X features support flight mode programming in heli mode

- Dual Rate & Exponential
- Servo Speed
- Programmable Mixes
- Throttle Curve
- Pitch Curve
- Fuel Mixture
- Needle Control
- Gyro Sensitivity
- Swash -> Throttle Mix
- Rudder -> Throttle Mix
- Governor

Aurora 9X sets 1/2 Idle up Hold by default.

Once you are familiar with settings for the Aurora 9X, choose your preferred switch options.

This is an additional condition for Normal condition when idle up is 1/2.

It is set to hold when switch E is located at the bottom in normal condition and idle up 1 is pulling up to the top and idle up 2 and switch G are pulling in middle step.

a. Press **FLT.COND** in the model menu.

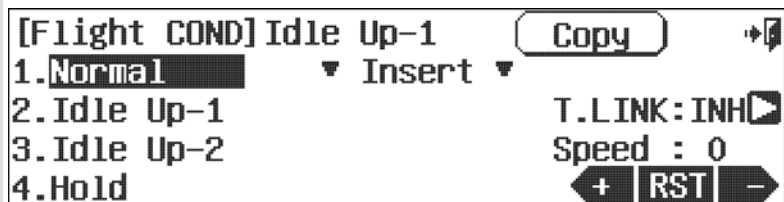

b. Idle-up 1 has been set by default as follows.

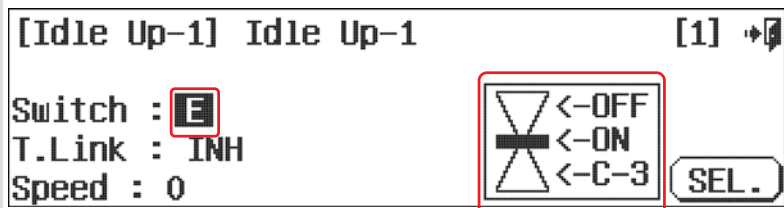

**FLT.COND (HELI)**

c. Idle-up 2 has been set by default as follows:

[Idle Up-2] Idle Up-2	[2] +
Switch : <b>E</b>	
T.Link : INH	
Speed : 0	

d. Hold has been set by default as follows

[Hold] Hold	[1] +
Switch : <b>G</b>	
T.Link : INH	
Speed : 0	

e. Click to the Exit icon to return to model menu.

**At this point we can choose to modify the existing flight conditions we made:**

1. Delete any of the flight conditions you made.
2. Renaming an existing flight condition to reflect its purpose.
3. Add more flight conditions and apply them to other switches.
4. Change the selected flight conditions priority.
5. Decide if you want the added flight conditions to have a "trim link".
6. Add a time delay to the activation of the flight conditions.

### Pitch and Throttle Curves (HELI)

#### P. Curve and T. Curve

In the Aurora 9X, both the pitch AND throttle curve functions are on the same menu, IF both pitch and throttle curve functions are "active". Additionally both menus are defined the same way, so to avoid repetition we will explain both throttle and pitch curve menus here.

If you have a collective pitch heli, pitch and throttle curve manipulation is mandatory to achieve the maximum performance capability from the machine.

The Aurora 9X can set up 7 points whenever you want for pitch curve, throttle curve and support the acceleration and exponential curve.



Those wishing a "pitch hovering trim" and "throttle hovering trim" capability will find it within their respective (adjust switch menu). More on this at the end of this section.

**### This function can be influenced by the flight condition feature ###**

To activate both Pitch and Throttle curve menus:

a. Press **P. Curve** in the model menu.

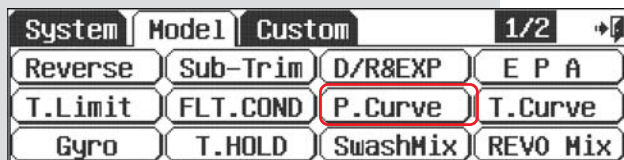

b. Press **ACT** to activate the Pitch Curve menu.



c. Press the **Exit** in the upper right corner of the screen to return to the model menu.

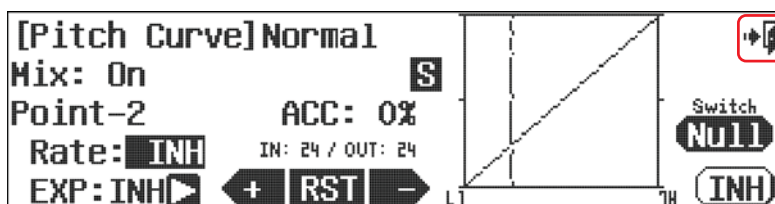

d. Press **T. Curve** in the model menu.

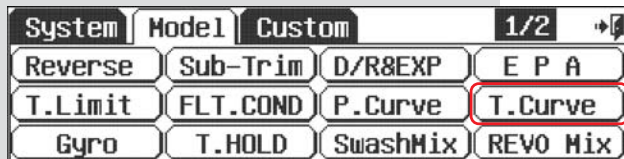

e. Press **ACT** to activate the throttle curve feature menu.



### Pitch and Throttle Curves (HELI)

f. Note the **THRO** arrow **NORMAL** line on the menu. Pressing the **arrow** will cycle you to the Throttle Curve menu.

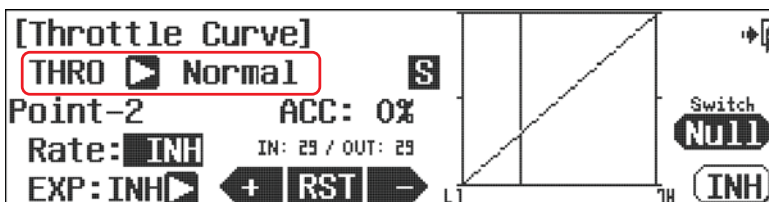

#### Switch Option and in flight Fine Trim Adjustment Switch Function.

g. To select a 2 or 3 position switch that will allow you to program multiple curve values, press **NULL** and follow the switch activation process. This is also the menu to apply the hovering pitch and throttle controls to the VR switches.

Switch type	Function	VR Adjust
2 or 3 position	Multiple values	Pitch and Throttle



You don't have to set a switch to have multiple curves at this point. Many users will choose to use the flight conditions / Idle-Ups to select between different curve values as the flight condition function will also influence the gyro, governor, dual and exponential rates plus many other critical mixes and functions.

h. Moving the throttle stick will change the location of the vertical line. This line represents the throttle stick position and lets you choose which curve point you want to adjust. Press the **+RST-** icon set point using the **+RST-** icon to adjust.

i. **INH** (turn off), or **ACT** (turn on) a point by using the throttle to place the graph line through the point you wish to change, press **RST**.

j. Add an exponential curve from one point to another by pressing the **Arrow** next to the **EXP: INH** icon and have it switch to **EXP: ACT**. This activates the expo option between it, the prior and the next point. Use the **+RST-** icons to add a value creating a curve.

k. Change the activation speed with the **ACC: 0%** icon, or acceleration feature. Again using the throttle to place the graph line through the point you wish to change, use the **+RST-** icons to change the acceleration value.

l. Select the **Exit** icon to return to the model menu.

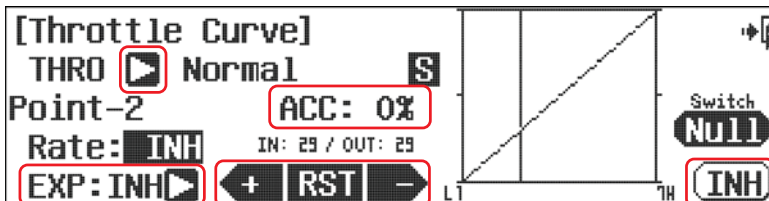

#### Throttle and pitch adjust feature

Program the LT, CT and RT VR switches to work as in-flight adjustment controls for 5 different throttle and pitch curve adjustment features. These adjustment menus are located in the Pitch and throttle switch set-up menus.

#### Throttle curve adjust options include;

1. Hover adjust
2. Hover with pitch adjust

#### Pitch curve adjust options include;

1. Hover adjust
2. High pitch adjust
3. Low pitch adjust



### Needle (HELI)

#### Carburetor Mixture Adjustment.

The Needle function is really two features: one is a manual needle adjustment independent of a mix. This is done by moving the LS slider control. The goal is to lean or richen the fuel mixture in relation to the blade pitch values. The second is a switched, automatic mix between a mixture control servo of a glow or gas heli motor, and the blade pitch.

There are two ways to activate this mix.

1. Use a slider. The default is the LS slider.
2. Direct mix to the pitch function activated with throttle stick movement.

**### This function can be influenced by the flight condition feature ###**

a. Select **Needle** from the model menu

b. Press **ACT**.



#### Switch Option

c. To select a 2 or 3 position switch that will allow you to program multiple values and apply an in-flight adjustment switch, press **NULL** and follow the switch activation process.

Switch type	Function	VR Adjustment
2 or 3 position	Multiple values	Fine tuning control choice

#### Direct needle control method

d. The first feature noted is the KNOB control of the needle mix. Move the LS slider and see the graph line shift across the screen. Use it to highlight the H or L rate value and use the **+RST-** icon to apply a movement value.

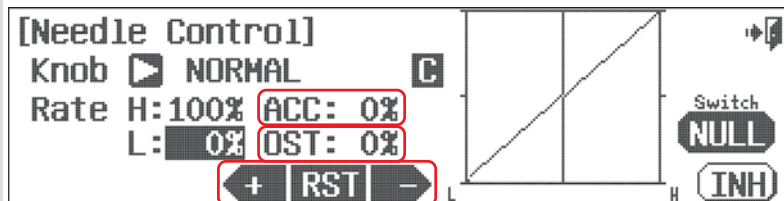

e. Try the ACC feature to change the speed of the mix. Press the **ACC: 0%** icon. Experiment with positive and negative values watching the results on your model.

f. Use the **OST: 0%** (offset) feature to manipulate the curve even more.

#### Mix to pitch method

g. Here we program the rate values for high and low needle servo movement in relation to the blade pitch movement. Move the throttle stick to highlight the H or L position and use the **+RST-** icon to set a value for the high and low position.

h. Try the ACC feature to change the speed of the mix. Press the **ACC: 0%** icon. Experiment with positive and negative values watching the results on your model.

i. Use the **OST: 0%** (offset) feature to manipulate the curve even more.

j. Select the **Exit** icon to return to the model menu.

## SWH-THR (HELI)

### Swash to Throttle Mix.

A swash to throttle mix is typically used to increase the throttle RPM when a swash input is given to the heli. The increased RPM compensates for loss of rotor disk lift as a result of the rotor disk tilt.

### This function can be influenced by the flight condition feature ###

a. Select the **SWH-THR** icon in the model menu.

b. Select **ACT** to activate the feature.



### Switch Option and In-Flight Fine Trim Adjustment Switch Function

c. To select a 2 or 3 position switch that will allow multiple mix values and to select an "in-flight" ADJUSTMENT switch, press **NULL** and follow the switch activation process.

Switch type	Function	VR Adjustment
2 or 3 position	Multiple values	Fine tuning control choice

d. Use the arrow icon to select the swash input, AILR or ELEV you wish to add throttle compensation for.

e. Move the control stick and use the **+RST-** icons to apply a travel rate for the direction of swash movement.

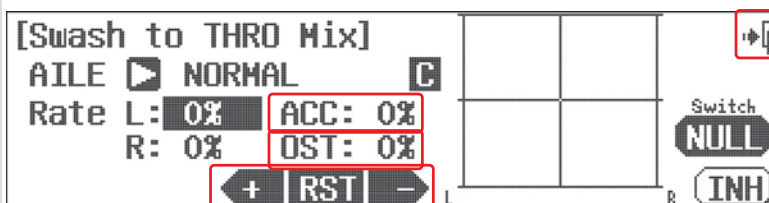

f. Use the ACC feature to change the speed of the mix. Press the **ACC: 0%** icon. Experiment with positive and negative values watching the results on your model.

g. Additional adjustment can be applied to the mix using the Offset, or **OST: 0%** value.

h. Repeat this process for all swash movement directions.

i. Select the **Exit** icon to return to the model menu.

### RUD-THR (HELI)

#### Tail Rotor to Throttle Mix.

This mix is between the rudder, or tail rotor input and the throttle. It is generally used to raise or lower the throttle RPM slightly to compensate for tail rotor dynamics.

### This function can be influenced by the flight condition feature ###

a. Select **RUD-THRO** from the model menu.

b. Press the **ACT** icon to enter the rudder to throttle mix menu screen.



#### Switch Option and In-Flight Fine Trim Adjustment Switch Function

c. To select a 2 or 3 position switch that will allow multiple mix values and to select an "in-flight" ADJUSTMENT switch, press **NULL** and follow the switch activation process.

Switch type	Function	VR adjustment
2 or 3 position	Multiple values	Fine tuning control choice

d. Move the rudder stick side to side to highlight the rate value you want to adjust.

e. Use the **+RST-** icons to add a throttle value for each side of the rudder movement input. Note how the throttle input movement values are shown on the graph.

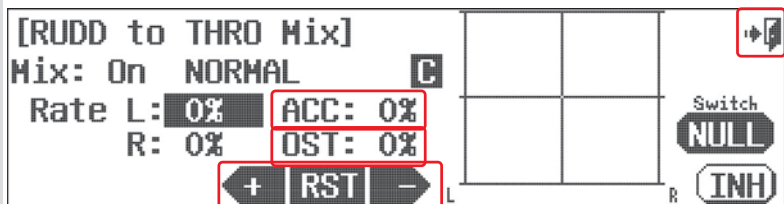

f. Use the **ACC** feature to change the speed of the mix. Press the **ACC: 0%** icon. Experiment with positive and negative values watching the results on your model.

g. Additional adjustment can be applied to the mix using the Offset, or **OST: 0%** value.

h. Press the **Exit** icon to exit back to the model menu.

## T. HOLD (HELI)

### Throttle Hold Position

Throttle hold is used to set the throttle at a programmed position when throttle hold is selected. This Function is often used to facilitate auto rotation maneuvers.

**### This function can be influenced by the flight condition feature ###**

To use the Auroras throttle hold feature; In our tutorial, we placed the hold switch on F.



Warning

The throttle hold feature will not work unless a hold position has been assigned a switch using the flight condition/idle-up function as was done on page 118 and 119.

a. Select **T.HOLD** from the model menu. T.Hold activation screen

b. Press **ACT** to activate the throttle hold menu.



Tip

At this point we can select a switch to place multiple hold positions on. However it is not necessary at this point, this can be done later through the switch menu, if you wish.

c. Press the **Rate1 : 0%** icon.

d. Use the **+RST-** icons to place a rate value for the hold position you want the throttle to be at when the hold switch is activated.

e. To set an activation delay, press the **Delay: 0** icon and set a value with the **+RST-** icons.

f. Press the **Exit** to return to the model menu.



Tip

Explore the throttle cut position and the (link to trim) selection as shown previously in this manual.

### Swash Mix (HELI)

#### Swash Plate Adjustment Menu.

Use the swash mix feature to apply a fine adjustment to the swash plate travel. For the very best accuracy, we recommend the use of a swash plate leveling set-up tool.



As this is a set-up feature, swash mix is one of the few functions that is NOT influenced by flight conditions, idle-up or hold conditions.

Our example will show a 120CCPM head format.

a. Select **SwashMix** from the model menu.

b. From this screen we can set a travel rate for the individual collective servos using the **+RST-** icon.



c. We can also reverse the direction of the collective input with the **REV** icon.

d. Are you sure? Press **Yes**, or **No**.

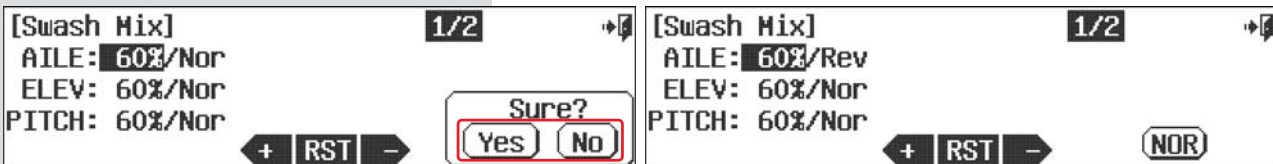

\* For most users this degree of swash accuracy is appropriate. To further adjust the swash, consult the next menu, Ring and Calibration.

#### Swash Ring menu

The swash ring function is used in order to prevent interference from the swash plate in movement of the aileron and elevator to master during extreme 3D flight.

e. Select **Ring** from the Swash Mix 2/2



f. Press the **ACT** icon to enter the swash ring menu screen.

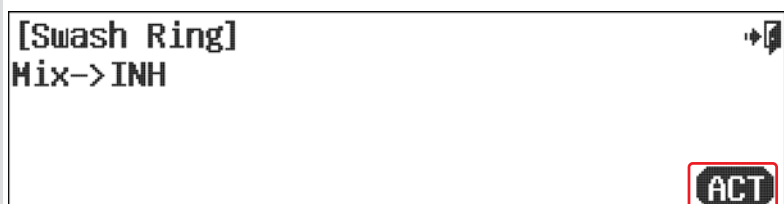

f. Increase / Decrease the setting value using the **+ RST -** icon.

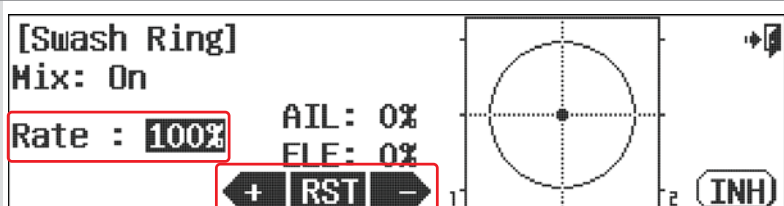

g. Press the **Exit** to return to the swash mix menu.

**Calibration menu**

The use of a swash leveling tool is mandatory for the super fine adjustment provided in this menu.

h. Select the **Calibration** icon.



i. From this intermediate menu, select the function to adjust. For our example select **Pitch**.

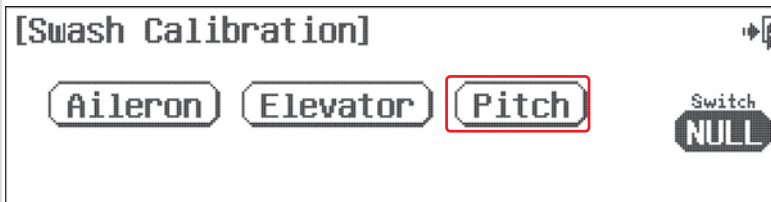

j. Select **ACT** Pitch calibration menu.



h. In this menu, we can modify the inputs of both the aileron and elevator in relation to the pitch function.

i. Select the **AILE** arrow to cycle to the ELEV, or elevator menu.

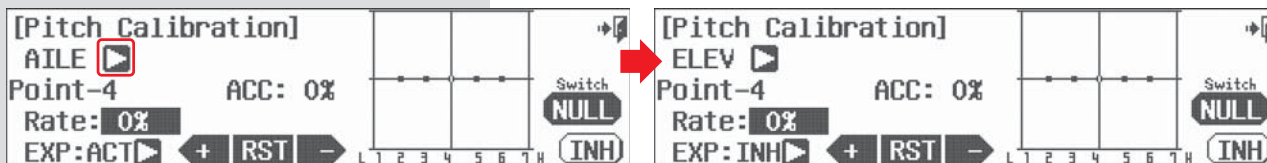

j. Move the elevator stick up and down to note the way it slides against the graph of the pitch line (the horizontal line in the middle with the little dots). Move the elevator stick over a dot to change the rate value with the **+RST** icon.

k. Inhibit (turn off), or activate (turn on) a point by using the throttle to place the graph line through the point you wish to change, press **RST**.

l. Add an exponential curve from one point to another by pressing the **arrow** next to the **EXP: INH** icon and have it switch to **EXP: ACT**. This activates the expo option between it, the prior and the next point.

m. Use the **+RST** icons to add a value creating a curve.

n. Change the activation speed with the **ACC: 0%** icon, or acceleration feature. Again using the throttle to place the graph line through the point you wish to change, use the **+RST** icons to change the acceleration value.

## Swash Mix (HELI)

### Switch Option

o. To select a 2 or 3 position switch that will allow multiple mix values, press **NULL** and follow the switch activation process.

Switch type	Function
2 or 3 position	Multiple values

p. When you are done programming the aileron and elevator controls on this screen, select the **Exit** icon to return to the swash calibration servo select menu.

q. Adjust the features of all the collective servos as necessary to achieve the desired swash movement effect.

r. Select th **Exit** icon twice to access the model menu.



**REVO Mix (HELI)**

**Revolution Mix.**

Revo, or revolution mixing is used to dampen the torque created by the main rotor speed and pitch variations during flight.



Revo mix is not used when a modern heading hold gyro is installed in the heli. The heading hold function of the gyro will correct the issue.

**### This function can be influenced by the flight condition feature ###**

a. Select REVO Mix from model menu.

b. Press ACT to activate the REVO Mix menu.



**Switch Option**

c. To select a 2 or 3 position switch that will allow multiple values, press NULL and follow the switch activation process on page 68.

Switch type	Function
2 or 3 position	Multiple values

d. The default rate for the mix is 30%. Change the value by lowering and raising the throttle to highlight the high or low positions.

e. Change the value with the +RST- icon. Note how the mix movement changes are shown on the graph.

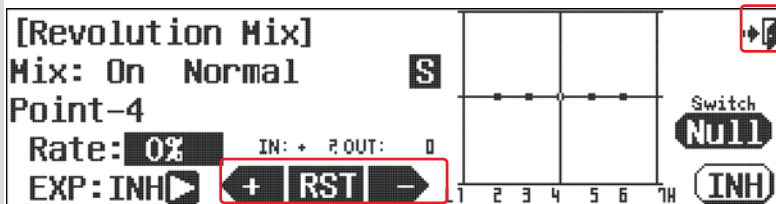

f. Press the Exit icon to exit back to the model menu.

### Gyro (HELI)

#### Gyro on/off and Sensitivity Adjustment.

Almost all modern helicopters use a gyro on the tail rotor control. The Aurora 9X offers you the ability to use a switch to have three different gyro "rates" per flight condition or "idle-up" and hold condition.

To effectively set-up the gyro function, you should have the gyro manufacturer's instruction manual available to you.

We will discuss the two main types of gyros, single and dual rate.

### This function can be influenced by the flight condition feature ###

#### Gyro set-up for helis

a. Select **Gyro** from the model menu.

b. Press **ACT** to activate the gyro menu.



Without selecting a gyro switch option, you will have one rate option in each flight condition or idle-up and hold settings. If you choose to set the gyro function on a switch, you can have a different rate value for each switch position, in each different flight condition or idle-up and hold condition.

We will keep it simple, and not select a multiple value switch for the gyro at this point. You can do it later if you wish.

#### Single rate gyro set-up

c. The default sensitivity value is 50%. Follow the gyro manufacturer's guidelines and apply an appropriate % value with the **+RST-** icons for each different idle-up and hold condition you have set.



#### Dual rate gyro set-up

d. Many modern gyros are dual rate heading hold products. To use a dual rate gyro select the Mode: Single arrow to change it to, **Mode: Dual** and press **Yes** when asked "Sure"?



e. Consult the gyro manufacturers documentation to determine what rate value should be applied. Use the **+RST-** icon to apply a rate % value for each idle-up and hold condition.

f. On the, **Rate1: 0%/NOR** arrow line, press the arrow to cycle between a normal and **T.lock** or throttle lock feature. This is used for bench testing the gyro rate sensitivity.

g. Select the **Exit** icon to return to the model menu.

## Gyro (HELI)



Note

- Most single rate gyro's will be in a heading lock mode with the rate values at or above 50%. A rate value below 50% is used for a "non-heading lock" or "rate" setting.
- Explorer the "adjust" function in the switch menu to apply an in-flight adjustment switch to fine tune your heli gyro setting.
- Be sure to set a rate value for each different idle-up and hold condition you have programmed. Note the C and S feature and how they might be used.

### Switch Option

As noted previously in the gyro instructions, if you want to have a switch that offers a different rate value for each switch position. See page 68 for the switch selection process instructions.

## Governor (HELI)

### RPM Governor Device Menu.

The Aurora 9X features up to three Governor and switch control rate values per model memory.

**### This function can be influenced by the flight condition feature ###**



Note

To effectively set up the governor function, you should have the governor manufacturer's instruction manual available to you.

a. Select **Governor** from the model menu. Governor activation screen

b. Press **ACT** to activate the governor menu.  
Governor screen

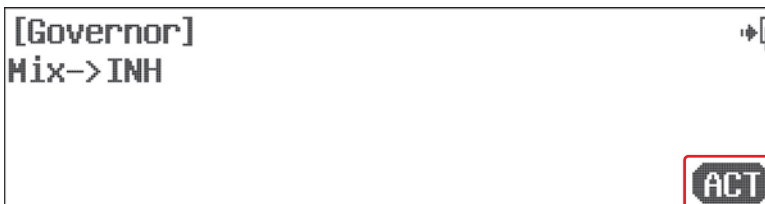

Tip

Without selecting a switch option, the governor rate can be different for all flight conditions or idle-up and hold settings. If you choose to set the governor function on a switch, you can have a different rate value for each switch position, and the screen will reflect this with a rate value option for rate 1, rate 2 or rate 3. To simplify this example we will set the governor up without a switch.

### Unit of Value, RPM or %

a. There are two Units of Value in the governor menu. Change the "Unit of value" for the governor display menu screen to either RPM value or % values by pressing the Unit: % arrow icon to cycle between RPM and %. Unless your governor manufacturer specifically calls for the RPM value, we suggest you use the % value.

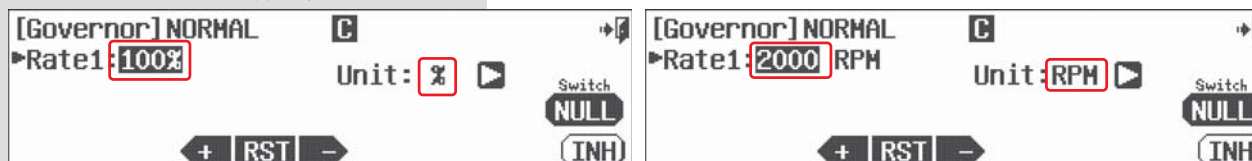

### Governor (HELI)

#### % Unit of Value operation

b. The default sensitivity value is 50% (1500RPM) and the Maxium value is 110%(2100 RPM). According to the governor manufacturer's guidelines, apply an appropriate % value with the +RST- icons. Set a rate value for all your idle-up and hold switch positions.

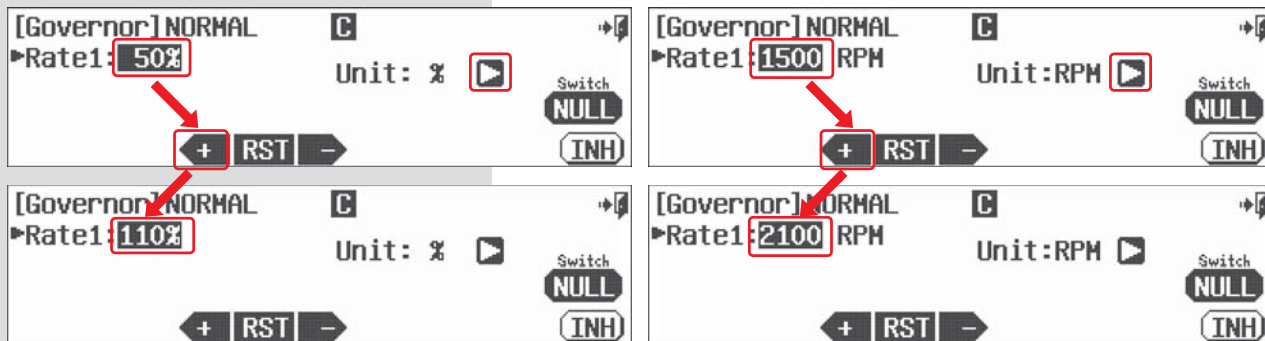

#### Switch Option

c. As noted previously in the governor instructions, we can choose a two or three position switch to apply multiple rate values. See page 68 for the switch selection process.

Switch type	Function	VR adjustment
2 or 3 position	Multiple values	Fine tuning control choice

d. Select the Exit icon to return to the model menu.



- Explorer the "adjust" function in the switch menu to apply an in-flight adjustment switch to fine tune your heli governor setting.
- Be sure to set a rate value for each different idle-up and hold condition you have programmed.  
Note the C and S feature and how they might be used.



# AURORA 9X

Instruction Manual

Evolutionary Genius 9 CHANNEL 2.4GHz AIRCRAFT COMPUTER RADIO SYSTEM

# AURORA 9X

CE11770

2.4GHz Band for use in :  
AT, BE, BG, CH, CY, CZ, DE, DK, EE, ES,  
FI, GB, GR, HU, IE, IT, LT, LU, LV, MT, NL,  
PL, PT, RO, SE, SI, SK, FR

Hitec RCD Inc.  
R/C Controller  
Model No : AURORA9X

This device complies with part 15 of the FCC Rules.

Operation is subject to the following two conditions:

- (1) This device may not cause harmful interference, and
- (2) This device must accept any interference received, including interference that may cause undesired operation.

English Manual Ver 1.1



Made in the Philippines