



HITEC 2.4GHz Receiver Instruction

version 1.0

• Risk of explosion exists if battery is replaced by an incorrect type. Dispose of the used battery according to the instructions.

European CE notice to users and product statements: This product is CE marked according to the provisions of the R&TTE Directive(99/5/EC). Hereby, HITEC RCD Inc, declares that this product is in compliance with the essential requirements and other relevant provisions of Directive 1999/5/EC. For further information, please contact <http://www.hitecrd.com>

FCC notice to users and product statements: THIS DEVICE COMPLIES WITH PART 15 OF THE FCC RULES. Operation is subject to the following two conditions: (1) this device may not cause harmful interference and (2) this device must accept any interference received including interference that may cause an undesired operation. CAUTION: Changes or modifications not expressly approved by the party responsible for compliance could void the user's authority to operate the equipment.

• FRANCE Frequency Range : 2.4056GHz~ 2.4482GHz



CE06780

2.4GHz Band for use in : AT, BE, BG, CH, CY, CZ, DE, DK, EE, ES, FI, GB, GR, HU, IE, IT, LT, LU, LV, MT, NL, PL, PT, RO, SE, SI, SK, FR

Made in the Philippines

Introduction

Thank you for your purchase of the Hitec Adaptive Frequency Hopping Spread Spectrum (AFHSS) 2.4GHz module and receiver system. This manual contains the complete directions on how to use the Optima series of receivers (version 3.00(0)). We encourage you to review the entire manual before using these products.

Service & Support

Hitec Customer Service

Help is available from the Hitec office through phone support and e-mail inquiries. Our US office is generally open Monday thru Friday, 8:00AM to 4:30PM PST. These hours and days may vary by season. Every attempt is made to answer every incoming service call. Should you reach our voicemail, leave your name and number and a staff member will return your call.

Hitec Website

Make plans to visit the Hitec website, www.hitecrd.com, on a regular basis. Not only is it full of specs and other information about the entire Hitec product line, our website's FAQ pages will eventually hold valuable information and program updates about the Spectra 2.4 module and Optima series of receivers.

The On-Line Community

One of the benefits of the extensive R/C online community is the vast wealth of archived knowledge available. Hitec sponsors forums on most of the popular R/C websites where a Hitec staff member or representative tries to answer all manner of product related questions. Bringing together strangers with common interests is proving to be one of the greatest gifts of the internet. If past history is any guide to the future, we are certain forums will be started about the Hitec 2.4 system and several are certain to stand out as valuable archives of information.

Warranty and Non-Warranty Service

All Hitec products carry a two year from date-of-purchase warranty against manufacturer's defects. Our trained and professional service representatives will determine if the item will be repaired or replaced. To provide all the necessary information we need to administrate your repair, visit our website at www.hitecrd.com and download the repair form, fill it out and send in your item for repair.

Hitec Service
12115 Paine St. Poway CA 92064
1-858-748-6948
E-mail: service@hitecrd.com



Warning!

1. For maximum performance, it is recommended to position the antenna at a 90 degree angle as shown in the picture below.

Recommended Position

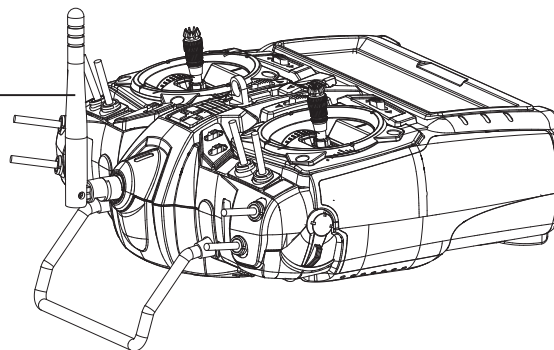

2. The receiver antenna should not be placed near the engine, metal parts or high current batteries.

3. When using a large number of high-power digital servos in a model, it is highly recommended to use the SPC feature to insure the receiver always gets the power it needs in high load conditions. If not, use the system with enough receiver battery capacity.

4. There could be a possible time delay in receiving telemetry data from the HTS-SS (sensor-station) depending on the conditions in the area you fly.

5. It is strongly recommended that you use Hitec's genuine Heavy Duty High Channel Switch Harness with Receiver Charger Cord (Stock#. 54407S) for all of Optima series of receivers.

OPTIMA Series Receiver Specifications & Features

Full Range AFHSS 2.4GHz Receivers

Receiver Model	Size	Weight	Stock Number
MINIMA 6T	1.19 x 0.81 x 0.27in (30.4 x 20.8 x 7.11mm)	0.22oz (6.5g)	26610
MINIMA 6E	1.24 x 0.81 x 0.42in (31.7 x 20.8 x 10.9mm)	0.22oz (6.5g)	26612
OPTIMA 6 LITE	1.76 x 1.11 x 0.29in (44.9 x 18.4 x 7.40mm)	0.33oz (9.4g)	29438
OPTIMA 6	1.81 x 0.82 x 0.47in (46.1 x 21.3 x 12.1mm)	0.52oz (15g)	28410
OPTIMA 7	2.20 x 0.79 x 0.43in (56.9 x 20.8 x 11.6mm)	0.60oz (17g)	28414
OPTIMA 9	1.85 x 1.14 x 0.59in (47.7 x 29.1 x 15.5mm)	0.77oz (22g)	28425

Operating Voltage : 4.8~7.4V From receiver battery power or speed control (ESC) power.
4.8~35V Using SPC function.

Max Current Consumption : 190mA

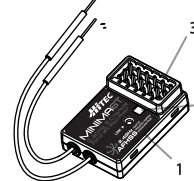

MINIMA 6T

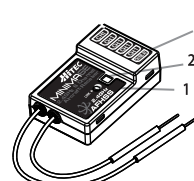

MINIMA 6E

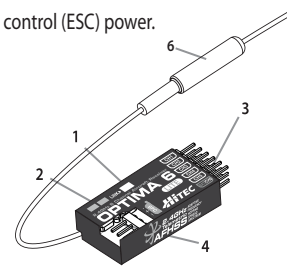

OPTIMA 6 LITE

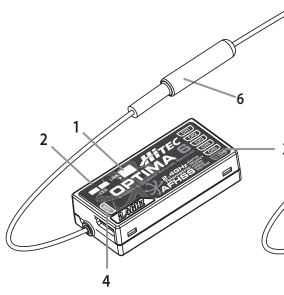

OPTIMA 6

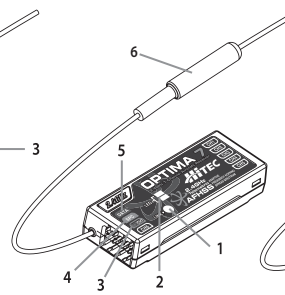

OPTIMA 7

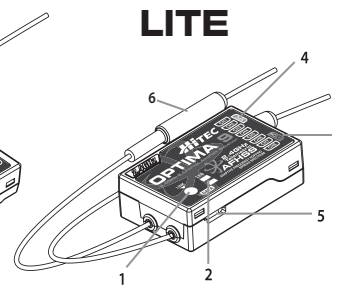

OPTIMA 9

1. Function Button

- Used for binding the receiver to a module or Hitec 2.4 built-in transmitters, entering the FAIL-SAFE or Hold feature.

2. Dual LED Status Indicator

- Indicates the set-up process codes and current status of the receiver.

3. Channel Output and Battery Input Ports

- The ports for battery power input and servos, gyros and other accessories output port are located at the side end of the Optima receivers.

4. SPC (Supplementary Power Connection)*

- Power the Optima receiver function with up to a 35V electric aircraft motor battery. Details about the SPC system can be found on page 2.

5. Telemetry Sensor and Data Port*

- A three pin servo plug connector port is featured on the Optima 7 and Optima 9 (not applicable on Optima 6). Using the HPP-22 PC interface accessory, this port serves to facilitate upgrading the device's software and interfacing the optional onboard sensor station.

6. BODA (Boosted Omni-Directional Antenna) System*

- Hitec's exclusive 2.4GHz BODA System will show you another means of using the 2.4GHz system. This single antenna with omni-directional booster makes it a whole lot easier to install the 2.4GHz antenna. Intensive tests have proven that the single BODA system in our 6 & 7 channel systems is better than or equal to our competitor's dual antenna systems. Our Optima 9 receiver features a dual BODA system to give the added security that larger models need. Installation is easy and simple, just insert the antenna into the supported antenna holder and stick it to the desired spot you wish to install.

Compatibility

- The OPTIMA & MINIMA series of receivers are compatible with transmitters using Hitec's AFHSS 2.4 GHz system such as Spectra 2.4 module or dedicated built-in module AFHSS 2.4 Hitec transmitters.

FAIL-SAFE/Hold Mode Selectable

- The positions of the servos and other accessories can be set with a FAIL-SAFE point, if power to the receiver is lost. See page 2 for details.

Low Onboard Battery Warning Function

While you are flying, you will know when the on-board battery is low with a warning alarm from the transmitter. Review the Low Battery alarm features that use direct telemetry feedback to your transmitter on page 2.

Jumper*

The jumper is installed at the factory and is used when the receiver is powered by an electronic speed control, a commercially available B.E.C. (battery eliminator circuit), dedicated 4.8 to 6V, NiMH battery pack or a regulated Li-Po battery. The jumper is removed when the receiver is powered using the SPC feature as described in more detail on page 2.

*These functions/ features are only for the OPTIMA series of receivers.

Receiver Connection Diagrams



-To see a receiver connection diagram for the SPC feature, see page 2.

Electric powered aircraft with Electronic Speed Control

Use this method on electric planes using ESCs providing power to the receiver and servo functions.

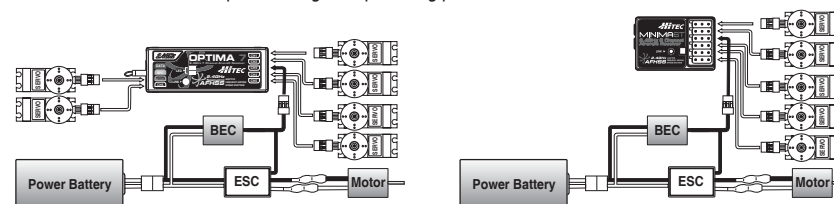

Glow, gas or electric powered aircraft using a separate receiver battery supply

Follow this connection diagram when using a regulated Li-Po or 4.8 to 6V receiver battery.

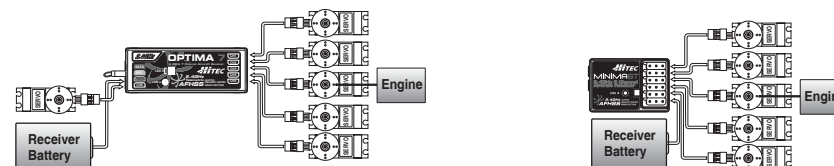

SPC (Supplementary Power Connection) System

Hitec's exclusive optional receiver power system allows you to directly power the receiver from the main motor power battery of an electric powered aircraft. Up to 35 volts can be fed directly into the receiver to power JUST THE RECEIVER FUNCTION. It will not power the servos. Almost all servos will burn up if more than 6 volts are used over a short period of time.



- Some Hitec servos are rated to be used at 7.4 volts. You will still need to supply power for your servos with a four or five-cell NiMH receiver battery or a 2-cell Li-Po and regulator set-up.
- The SPC system was partially created to be integrated into future Hitec telemetry system devices. Check the Hitec website for more information on the availability of telemetry systems in the future.

SPC Connection Diagram

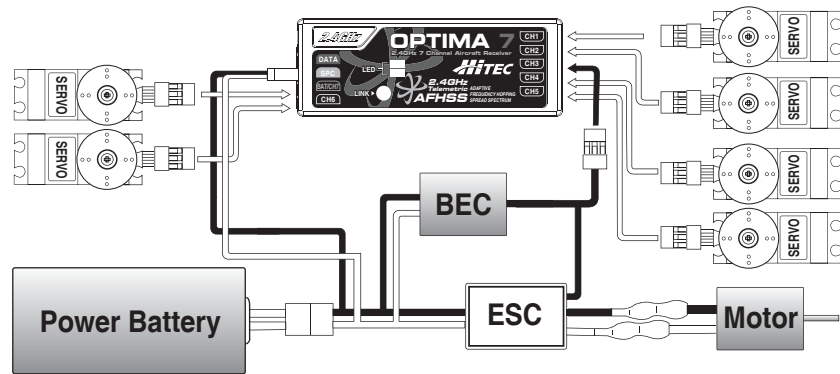

- The SPC function is applicable to the OPTIMA series of receivers only.

Link (ID-Setting)

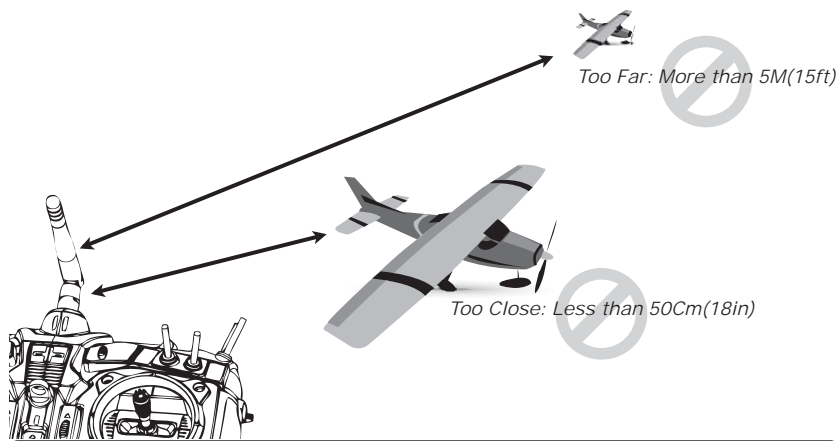

- Link must be done within 15ft. (5m) of the transmitter and receiver.
- Transmitter and receiver need to be at least 18in. (50cm) from each other to link properly.

Link (ID-Setup or Bind)

Your Hitec AFHSS system uses a communication protocol that links and binds the Hitec 2.4GHz receiver to your transmitter. Once the receiver and module are "bound," no other transmitter can interfere with your receiver during its operation. In the case of multiple model memory transmitters, you can bind as many Hitec 2.4GHz receivers to your transmitter, one per model memory as necessary. Each module and receiver set is paired at the factory for your convenience.

Use one of the following binding methods to bind additional Hitec 2.4GHz receivers to your transmitter.

Non-telemetry RXs (MINIMA & MICRO Series)

1 Press and hold the button on the module, and turn on the transmitter.

2 Release the link button.

3 Check if the BLUE LED is blinking. If the RED LED is blinking, press the link button for 2 sec., so that the LED changes to BLUE.

4 Press and hold the link button on the receiver and turn on the power.

5 Both RED and BLUE LEDs will blink rapidly to find the transmitter signal. Release the link button when the RED LED on the receiver glows steady.

6 When the link is completed, the BLUE LED on the module will blink while the BLUE LED on the receiver glows steady.

7 To save the setting, please reboot both the transmitter and receiver.

When they are turned on again, the RED LED on the module (or radio) and the BLUE LED on the receiver will glow steady.

Telemetry RXs (OPTIMA Series)

3 Check if the RED LED is blinking. If the BLUE LED is blinking, press the link button for 2 sec., so that the LED changes to RED.

5 Release the link button.

6 When the link is completed, the BLUE LED on the module will blink while the RED LED on the module glows steady. For the receiver, both BLUE & RED LEDs will glow steady.

When they are turned on again, you will hear a continuous beep sound. Both the RED LEDs on the module and receiver will glow steady in normal status.

FAIL-SAFE and Hold Mode Setup

If the receiver signal somehow becomes interrupted or interference occurs, the servos will move to the pre-set FAIL-SAFE point you previously stored in the FAIL-SAFE set-up. Make sure you set the FAIL-SAFE function properly.

If FAIL-SAFE has not been activated, the signal will switch off after the HOLD period of one second. This means that the servos become "soft" and remain in their last commanded position under no load (this may equate to full-throttle!), until a valid signal is picked up again.

In the interest of safety, we recommend that the FAIL-SAFE function should always be activated, and the FAIL-SAFE settings should be selected so as to bring the model to a non-critical situation (e.g. motor idle / electric motor OFF, control surfaces neutral, airbrakes extended, aero-tow release open, etc.).

1

Switch on both. Wait for the system to boot and gain control over the model.

2

Press and hold the button on the receiver until the LED turns off (approx. 6 seconds)

3

Release the button. After 2 seconds, both RED and BLUE LEDs blink alternately. The receiver will count 5 seconds, during that time, move all the transmitter sticks and other controls to the desired FAIL-SAFE positions (e.g. motor idle, control surfaces neutral). Hold until blinking stops.

4

When blinking stops, the system will temporarily remember the FAIL-SAFE position. Turn off the system to save and exit.

Testing the FAIL-SAFE Setting

- Move the sticks to positions other than the FAIL-SAFE settings and then switch off the transmitter. The servos should now move to the FAIL-SAFE positions previously stored, after the one second HOLD period.

How to turn FAIL-SAFE Off and reactivate the Hold Mode

- Switch on the transmitter then the receiver. Wait for the system to boot and you have control over the model.
- Press and hold the receiver function button for 6 seconds and release. After 2 seconds, the RED and BLUE LEDs will blink rapidly.
- Immediately press the button once.
- FAIL-SAFE Mode is now deactivated and HOLD mode is activated.
- Turn the transmitter off then the receiver off.
- Turn the system back on to use it.



- If FAIL-SAFE is deactivated, the FAIL-SAFE position settings are also deleted!
- The FAIL-SAFE settings should be checked every time before you run the engine/motor.

Telemetry System

The Hitec Spectra 2.4 Module and Optima Series of receivers feature full telemetry capabilities (except Optima 6) and include a Low Receiver Battery Warning as a basic function.

I. Basic Function: Low Onboard Battery Warning - for All Optima Receivers

When the Optima series of receivers is powered up, it will automatically detect the battery voltage level and recognize between 4-cell or 5-cell NiMH and NiCd batteries (4 cell < 5.8V < 5 cell). In case a 2-cell LiPo battery is being used, you can customize the battery warning level by using the HPP-22 PC program.

- When the battery level is safe (4 cell > 4.5V, 5 cell > 5.6V), there will be no change to the LED lights.
- When the battery level is low (4 cell < 4.5V, 5 cell < 5.6V), the BLUE LED glows constantly and the RED LED will blink fast. You will hear three continuous beeps from the module as a low receiver battery warning. Upon hearing the beeps, we advise you to land at once.

II. Optional Functions:

GPS, FUEL, TEMP, O-RPM, M-RPM, VOLT, Amp Sensors - Applicable for Optima 7 & 9 Only

- More devices will be available in the future. Check the Hitec website at www.hitecrd.com for more up-to-date information.



- The telemetry function is applicable for the OPTIMA series of receivers only



- Low Battery Warning function is only for your reference. The actual battery level could be different. Battery Memory Effects such as Lazy Battery Effect or Battery Memory could affect the Low Battery Warning function.
- When the 2.4GHz system and HV servos are used together, we strongly recommend using fully-charged, large capacity battery packs and you must constantly monitor the battery status.